

SURFOX 306

USER MANUAL



SURFOX
website

TABLE OF CONTENTS

1. Safety	5
1.1. Personal protective equipment (PPE)	6
1.2. Protection systems built into the device	8
1.3. Residual risks	8
1.4. First aid measures	8
2. Device characteristics	9
2.1. Fields of application	9
2.2. Basics of passivation	9
2.3. Transport and storage of the device	9
2.4. Device components	10
2.5. How to install the accessories	12
3. Control panel	14
3.1. General description	14
3.2. Changing the language	14
3.3. Menu structure	15
3.4. Power adjustment	16
3.5. Pump adjustment	17
3.6. Alarm messages	18
4. Mounting accessories on the wand	19
4.1. Overview of accessories	19
4.2. Installation of brush adaptor / inserts	20
4.3. Mounting brushes	21
4.4. Mounting pad on graphite insert 100 mm	22
4.5. Mounting pad on graphite insert 45 mm	22
4.6. Mounting pads with PTFE clamp ring	23
4.7. Brush bristle length adjustment	24
4.8. Direction of inserts	24
5. Before device startup	25
5.1. Precautions for the use of the device	25
5.2. Filling the tank	26
5.3. Connection to the compressed air circuit	26
5.4. Electrical installation	27
6. Cleaning and polishing of welds	28
6.1. Start of processing	28
6.2. After processing	31
6.3. Shutdown	31
7. DW wand (optional)	32
7.1. Overview of DW wand accessories	32
7.2. Installation of inserts / brush adaptor	33
7.3. Mounting pad on graphite insert 100 mm	33
7.4. Mounting pad on graphite insert 45 mm	34
7.5. Mounting DW brush	35
7.6. Electrical installation	36
7.7. Start of processing	37
7.8. After processing	40
7.9. Shutdown	40

8. Marking/Etching (optional)	41
8.1. Overview of marking/etching wand accessories	41
8.2. Marking insert installation	42
8.3. Mounting a pad on the marking insert	42
8.4. Electrical installation	43
8.5. Start of processing	44
8.6. After processing	45
8.7. Shutdown	45
9. Maintenance	46
9.1. Routine maintenance	46
9.2. Extraordinary maintenance	46
10. Disposal and scrapping	47
10.1. Packaging	47
10.2. Used pads	47
10.3. Waste liquids	47
10.4. Obsolete devices and equipment	47
11. Declaration of Conformity	48
12. General Warranty Conditions	54
13. Repair and Service	55
14. Technical specifications	57

It is necessary to read carefully the instructions of this manual before any operation.

This manual provides the main information for adequate and safe installation, start-up, operation and maintenance of the device.

This manual is intended to familiarize the user with this unit, its particular features, applications, limitations, and the manufacturer's suggestions and recommendations.

The manual is an integral part of the device and should be stored with care until the unit is dismantled.

This manual reflects the state of the device at the time of delivery and cannot be regarded as inappropriate simply because of later updates based on additional experience.

This device is built with extra durability to stand up to the heavy demands of industrial use. However, like any piece of electrical equipment, care and safety should always be taken when using and maintaining this valuable investment. With proper care and maintenance, your unit will provide years of reliable service.

WALTER CUSTOMER ASSISTANCE DEPARTMENT (walter.com) is at your disposal to provide all the marketing and user information.



1. SAFETY



WALTER's SURFOX 306 is produced in accordance with applicable standards governing the manufacture, performance and safety of industrial products.



All persons in charge of device installation, operation, maintenance and repair must possess the appropriate technical qualifications and must meticulously comply with the provisions of this user manual.

To reduce the risk of fire, electric shock, and personal injury, always follow basic safety precautions when using this equipment.

OBLIGATIONS OF THE PERSON IN CHARGE OF THE DEVICE

The owner of the device and/or any person responsible for safety are required to:

- Ensure that all users of the device are adequately trained as regards current occupational health and safety regulations.
- Ensure that all users of the device have read this user manual in its entirety and have understood all of it, in particular the sections on safety standards.
- Periodically check that all personnel always operate in compliance with safety standards.
- Inspect the equipment regularly to ensure that it is operating properly and performing its intended function. Damaged or defective parts must be repaired or replaced immediately by **WALTER** qualified personnel only. Refer to spare parts list for the ordering number and contact a **WALTER** Factory Service Center or **WALTER** Authorized Service Center.
- Periodically check that all the safety signs affixed to the device (data plate, stickers bearing danger symbols, etc.) are clearly legible and not damaged, overwritten, removed or obscured by other objects.

OBLIGATIONS OF THE USER

Personnel authorized to use the device must:

- Operate in accordance with current occupational health and safety regulations.
- Read this user manual carefully, paying particular attention to the sections on safety standards.
- Sign a document in which they declare that they have read and understood this manual, and that they undertake to follow all the instructions contained therein.
- When working, always wear personal protective equipment and clothing (see *chapter 1.1*).
- Use the device only as explained in this manual; improper use increases the risk of accidental personal injury and/or property damage.
- Stay alert at all times when handling this unit. Watch what you are doing. Use common sense. Do not operate the device if you are tired. Never leave it running unattended.
- Do not use the unit if the switch does not turn ON and OFF.
- Hold the wand firmly. Do not overreach, maintain good footing and balance at all times.
- Keep the work area clean and well lit. A cluttered environment invites accidents. Remove any material that may be ignited by sparks. Do not use this equipment in the presence of flammable liquids or gases. Keep handles clean, dry and free from cleaning solution, oil and grease. Do not use in rain, damp or wet locations.
- Take appropriate precautions and always secure the device during periods when the workstation is not manned (such as during breaks or at the end of the shift).
- Do not abuse the power cord. Never pull or lift this unit by its cord or yank to disconnect it from the outlet. Keep the cord away from heat, oil, and sharp edges. Inspect the cord regularly and have it replaced by a **WALTER** Factory Service Center or **WALTER** Authorized Service Center if damaged.
- Keep children and others away from the work area. Make sure no one is under you when working in high places. Do not allow unqualified persons handle this machine.

1.1. PERSONAL PROTECTIVE EQUIPMENT (PPE)

The use of this device entails several risks, therefore the use of appropriate personal protective equipment (PPE) is necessary.



ELECTROLYTE SOLUTIONS

For its normal operation, the device requires the use of special electrolyte solutions that contain phosphoric acid.

These products are dangerous because:

- They are corrosive.
- They may cause irritation and burns if they come into contact with the skin or mucous membranes.
- If they come into contact with the eyes, they can cause serious eye damage.
- Using them exposes the operator to the risks typically associated with the use of chemical substances.

In addition, during processing, these substances:

- Conduct potentially dangerous high electrical current flows if you touch them.
- Release harmful fumes when they evaporate.

Do not use products other than those indicated in this manual (otherwise any form of warranty will be voided) and do not mix these products with others.

Always store these substances in a safe place in their original containers, out of the reach of children and other unqualified persons. Keep container contents clean. Do not reuse electrolyte cleaning solutions.

In case of accidental contact with the eyes or skin, or if swallowed, follow the instructions shown on the product safety data sheets (MSDS).

See also *chapter 1.4*, where some first aid measures are illustrated.

You can request a copy of the safety data sheets for electrolytic solutions at:

WALTER

Phone (US): +1 866 592-5837

Phone (CA): +1 888 592-5837

Website: walter.com



All users of the device must wear appropriate work clothing in order to mitigate the risks related to the use of electrolyte solutions. The clothing must meet the following requirements:

- Gloves must be made of materials that are resistant to acids and chemicals.
- All garments must be waterproof to ensure better protection for the user.
- Clothes and protective devices must always be intact and kept in good condition.

It's important to keep the device as clean as possible to reduce the risk of accidental contact with electrolyte solutions.

The operations performed with this device **must be carried out in well ventilated places.**

If this is not possible, as for example in the case of use in confined spaces (silos, sewers, tanks, furnace combustion chambers, pipes, etc.), **an adequate extraction system must be implemented.**

The SURFOX 306 is equipped with a built-in fume abatement system:

- **Blowing wand**

The blowing wand **is activated via connection to an external compressed air circuit.**

If the blowing wand is not used, such as during operations carried out with the DW wand, **the fume abatement system built into the device shall not operate and a suitable external fume extraction apparatus must be used.**



BURN PREVENTION

During the cleaning process, the wand tip and work piece can reach very high temperatures:

- Very hot parts can cause skin burns upon contact.
- Do not touch the wand tip or work piece while working or immediately after use, they may be extremely hot and could cause serious burns.
- Allow to cool before coming in contact with exposed skin.

Be very careful when handling a newly processed piece and when removing the pads and inserts.



All users of the device must wear suitable protective gloves for the handling of the parts and for the use of the wand.



ELECTRIC SHOCKS

All electric shocks are potentially fatal, so it is necessary to take appropriate safety measures to minimize the risk of electric shock:

- **Before connecting this unit, check that the voltage and amperage shown on its rating plate match the power supply. Operating this unit other than specified on the rating plate may result in personal injury to the user and damage the unit.**
- **The device must be connected to a mains power supply fitted with an efficient, functioning and periodically tested earthing system. Otherwise, the manufacturer is relieved of any liability for any loss or damage caused by this serious act of negligence.**
- This unit is equipped with a 3-conductor power cord and a 3-prong electrical plug that must be connected to an appropriately grounded electrical outlet.
- Do not use the device in damp rooms.
- Never touch live parts.
- Never operate the unit with its protective cover removed.
- Always switch off the device if the workstation remains unattended (during breaks and at the end of shifts).
- Frequently inspect the power supply cable and if there is any damage or abrasion to the protective coating, replace it immediately.
- When not in use, turn OFF the unit, unplug the power cord and the air hose (if any).
- **Carry out maintenance only after disconnecting the device from the mains.**
- Maintenance of electrical parts must only be performed by experienced and authorized personnel.
- Always use original spare parts.

If while using the device you experience even the slightest sensation of electric shock, switch off the unit immediately and do not use it until the problem has been identified and resolved by qualified personnel.



All users and maintainers of the device must wear insulating gloves to protect themselves from accidental contact with live parts.

To maximize safety, it is preferable to always use insulating tools when performing maintenance operations.

1.2. PROTECTION SYSTEMS BUILT INTO THE DEVICE

THERMAL PROTECTION

All SURFOX units automatically shut down if excessive overheating is detected on the inverter board.

When this protection system is activated, the device immediately shuts down and cannot be restarted until it has cooled down; once the temperature has returned to normal levels, the unit automatically resumes operation.

To prevent the unit from overheating, air must flow freely through the air vents. Maintain a minimum clearance of 8" (20 cm) around the unit to ensure that all air openings are clear of any obstruction.

PROTECTION AGAINST SHORT CIRCUITS

All SURFOX units are equipped with a built-in short circuit protection system that can occur between the insert installed on the wand and the workpiece, in particular when the currents involved are high.

In the rare cases in which this happens, the system is designed to automatically intervene and terminate the flow of current to the wand; in this way the device electronic parts are safeguarded. The operation of the unit is restored immediately once the electrode has been removed from the workpiece.

If the device repeatedly trips, it is recommended to check the wear of the consumables (e.g. pads) or to use lower operating voltages.



Do not disable and/or bypass the device's built-in protection systems.

1.3. RESIDUAL RISKS

The risks involved in the use of this devices are significantly reduced if both the safety rules indicated in *chapter 1.1* and the instructions for use shown in this manual are followed.

However, there are still risks arising from the high temperature reached by the electrode, possible contact with electrolyte solutions and the operator's potential exposure to harmful fumes generated during processing; therefore, it is advisable to always follow all the safety procedures described in this chapter.

1.4. FIRST AID MEASURES



In the event of accidental exposure to electrolyte solutions or fumes produced during processing, please remain calm and avoid any unintentional or harmful actions. It is recommended that you comply with the following guidelines:

- In the case of inhalation of processing fumes, try to ensure an inflow of fresh air into the respiratory tract and aerate the surrounding environment when possible. If there are any subsequent respiratory tract complaints, seek medical advice.
- If the skin comes into contact with acid solutions, wash it immediately with running water and soap; if after drying you experience persistent skin irritation, consult a dermatologist or doctor.
- If acid solutions are swallowed, DO NOT induce vomiting. Call an ambulance immediately and in the meantime repeatedly rinse your mouth and then drink copious amounts of water.
- If a certain amount of electrolyte comes into contact with your eyes, rinse your face thoroughly while trying to keep your eyes open. Repeat the operation for at least 15 minutes, lifting eyelids occasionally. Use an emergency eyewash if available. If possible, remove any contact lenses and continue rinsing. If irritation or subsequent visual complaints persist, consult an ophthalmologist or doctor immediately.

2. DEVICE CHARACTERISTICS

2.1. FIELDS OF APPLICATION

WALTER's SURFOX 306 quickly, easily and cost effectively removes the heat tint from heat affected zones on stainless steel and aluminum while completely passivating the stainless steel surface.

The device is equipped with self-regulating inverter boards that automatically monitor and adjust the current to ensure maximum cleaning efficiency without loss of productivity.

An electrochemical process allows the SURFOX 306 to clean and passivate welds on stainless steel. SURFOX electrolyte solutions are phosphoric acid based, approved for food industry, and are activated by an electrical current to clean welds. The process takes only a few seconds without damaging or scratching the surface of the parts to be cleaned.

YOUR SURFOX 306 CAN CLEAN:

TIG welds, Plasma welds, Laser welds, Spot welds, MIG welds, Stick welds.



Special care must be taken when using this device on particularly delicate steel surfaces (e.g. AISI 430), as permanent white halos may form during processing.
If in doubt, it is good practice to first perform a test on a sample of the same type of steel.
For further information contact **WALTER CUSTOMER SERVICE REPRESENTATIVE (walter.com)**.



WALTER is not liable for loss or damage caused by the device if used outside the fields of application mentioned above.
SURFOX devices are designed for industrial applications, so their use in the home is strictly prohibited.

2.2. BASICS OF PASSIVATION

The cleaning of the welds is not only for aesthetic purposes but most importantly for passivation.

Passivation is the treatment of stainless steel surfaces to remove contaminants and promote the formation of a thick and durable protective chromium oxide layer.

This passive layer will insure the corrosion resistance of stainless steel. If passivation is not done properly, stainless steel and heat affected zones may start to rust.

2.3. TRANSPORT AND STORAGE OF THE DEVICE

To facilitate transport, the SURFOX 306 is equipped with a handle at the top. See *chapter 14* for detailed information on the size and weight of the device.

Make sure the switch is in the OFF position before connecting or moving the unit to avoid unintentional starting.

The device must be kept in a sheltered and moisture-free place to protect its internal electrical components.

If the machine is to be stored for an extended period of time, the cleaning solution reservoir and supply line must be emptied, cleaning accessories removed, neutralized, rinsed and dried. The device must be carefully packed in a suitable container and properly protected, in particular from exposure to freezing temperatures. Store the unit in a safe place, out of the reach of children and other unqualified persons.



WALTER will not be held responsible for any damages resulting from leaked cleaning solution or rough handling.



The handle is designed exclusively for carrying the device by hand.
Do not use it as a hook-up point for the forks of forklifts or other lifting machinery.



If it is necessary to return the SURFOX 306 to the **WALTER** Factory or Authorized Service Center, please follow the instructions in *chapter 13* to carefully prepare and pack the shipment.

WALTER is not liable for any loss or damage to persons or property due to the leakage of electrolyte solution from the reservoir during packing operations and shipping to service centers.

2.4. DEVICE COMPONENTS

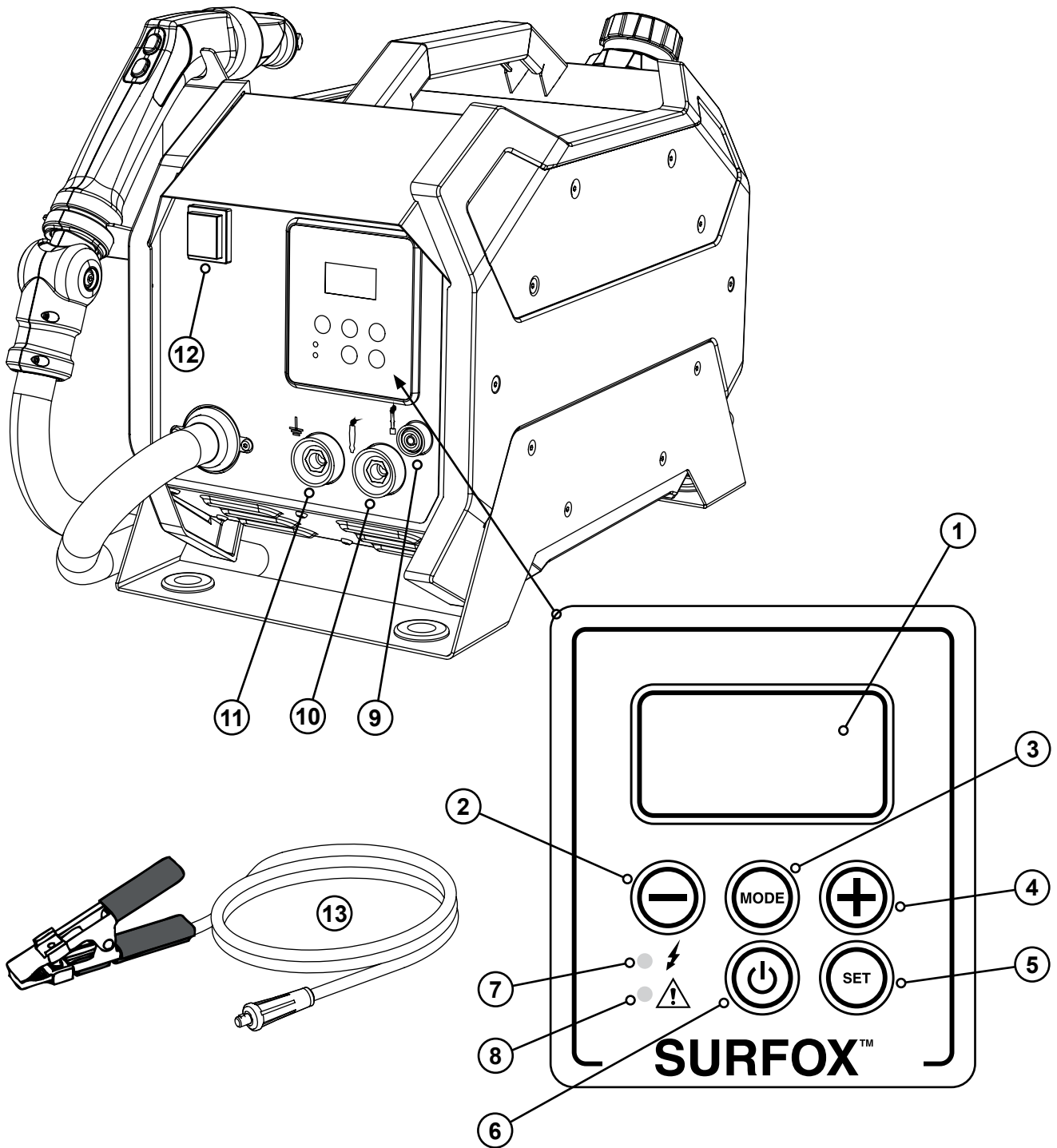

1	Display	8	Alarm LED (red)
2	Voltage decrease button	9	Black socket for marking wand
3	MODE button	10	Black socket for DW wand
4	Voltage increase button	11	Red socket for ground cable
5	SET button	12	Main switch (ON/OFF)
6	Power button	13	Ground cable
7	Power LED (green)		

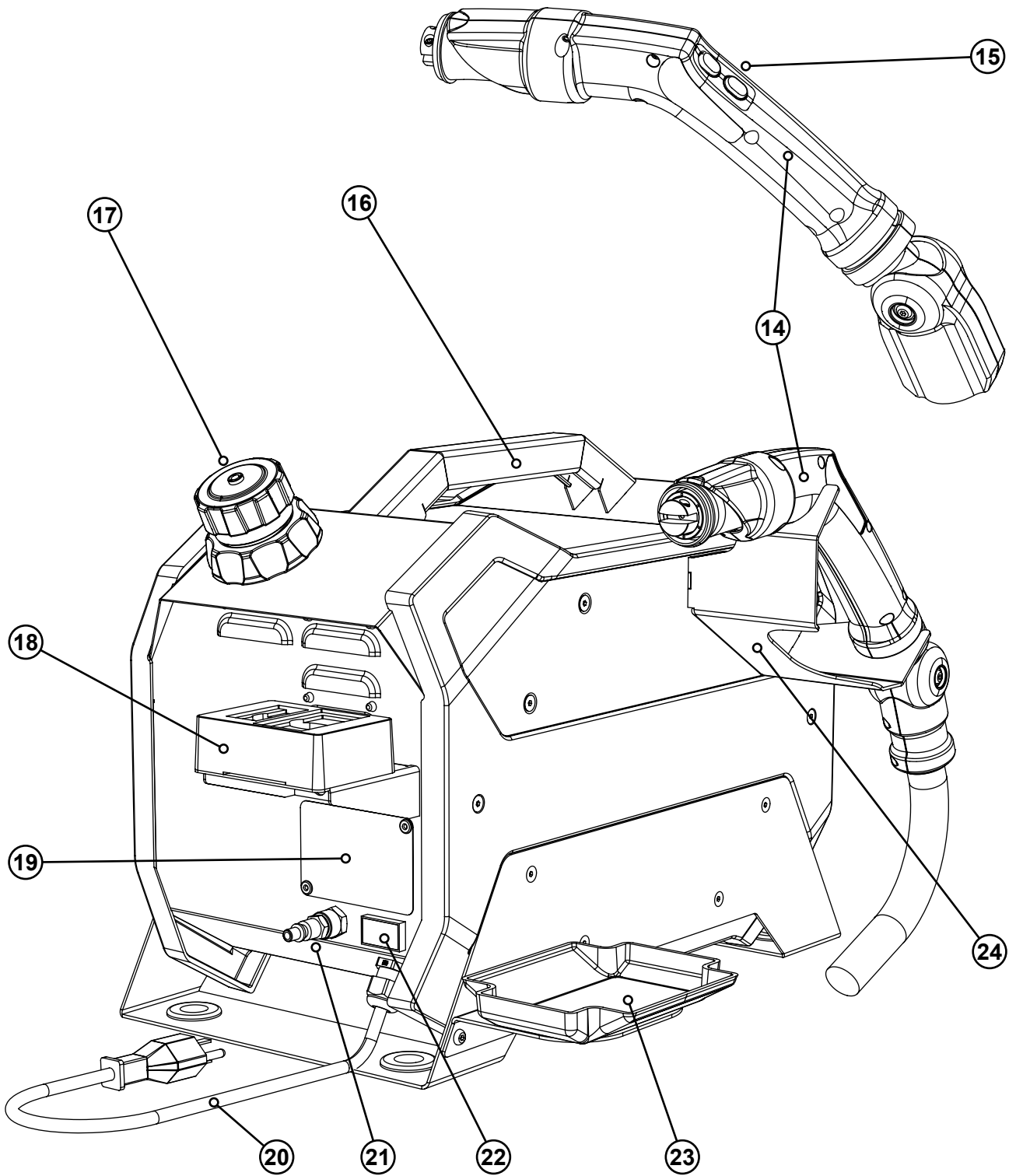

14	Blowing Wand	21	Compressed air connector
15	Wand control buttons (START/STOP)	22	Serial number
16	Handle	23	Collecting tray
17	Tank cap	24	Wand holder
18	Pad mounting tool		
19	Rating plate		
20	Power cord		

2.5. HOW TO INSTALL THE ACCESSORIES

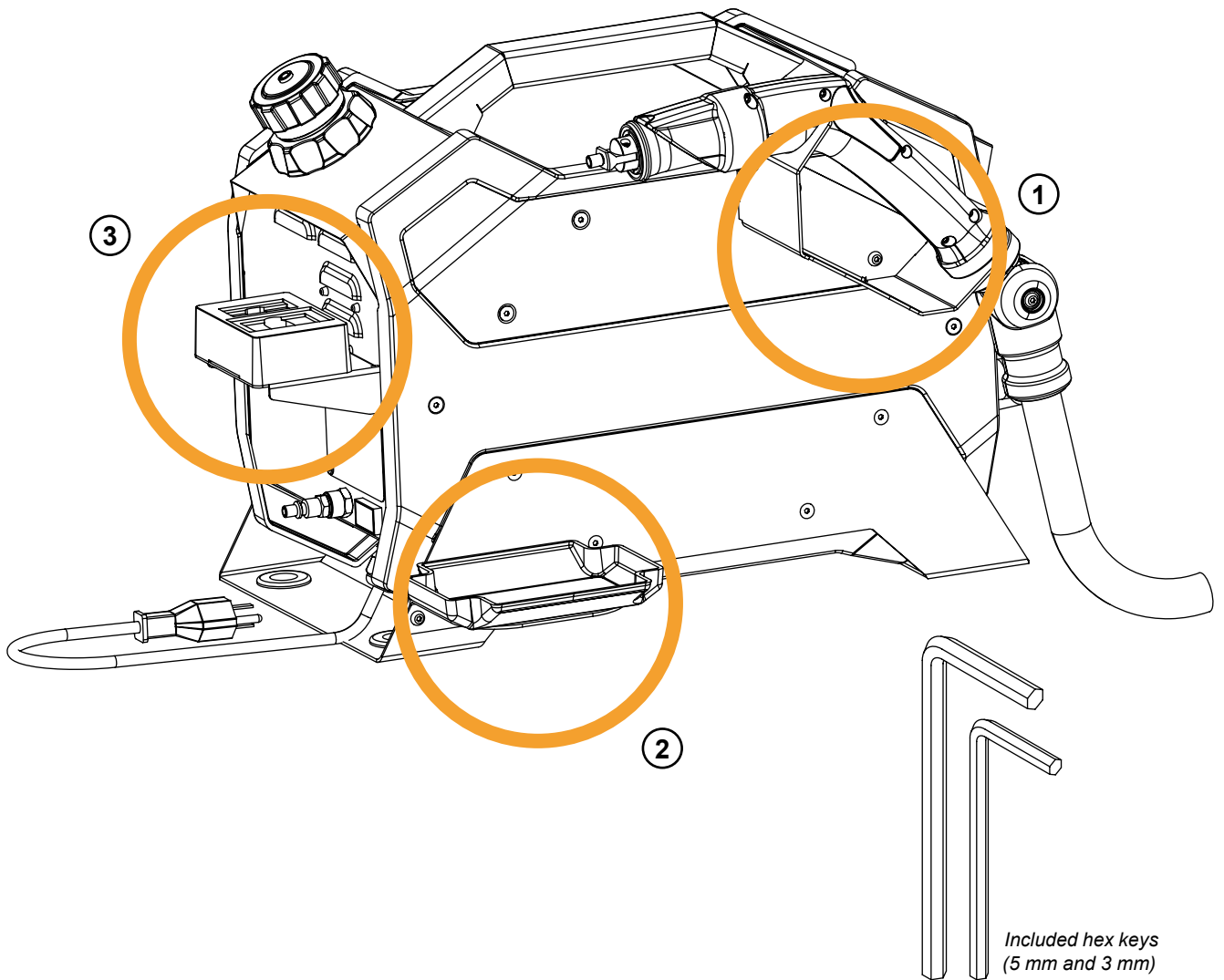

1. WAND HOLDER

- Align the wand holder with the proper holes on the left side of the unit.
- Use a 3 mm hex key (included) to tighten the two mounting screws.
- The longer screw (M5X25) must be installed in the top hole.
- The shorter screw (M5X10) must be installed in the lower hole.

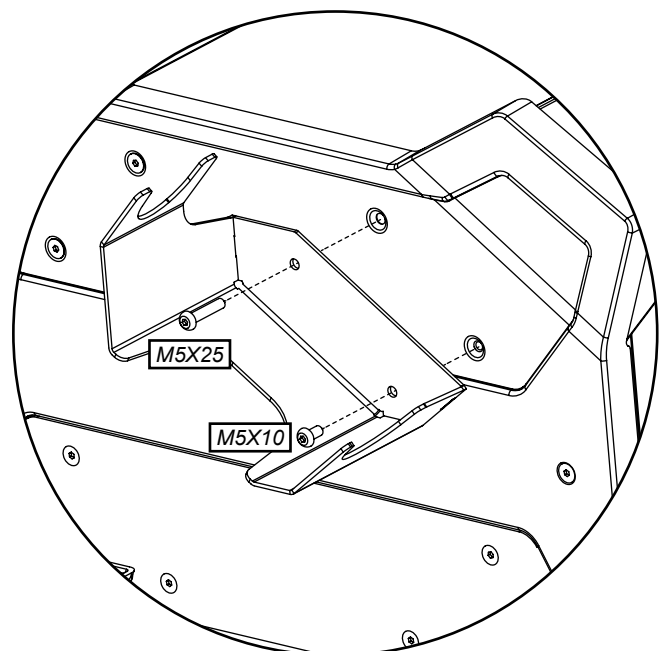

2. COLLECTING TRAY

- The collection tray consists of two parts: the bracket (A) and the tray (B).
- First, use a 3 mm hex key (included) and two M5X8 screws to install the bracket into the corresponding holes on the left side of the unit.
- Then install the tray, which is equipped with magnets and requires no tools to fit into the slot on the bracket.

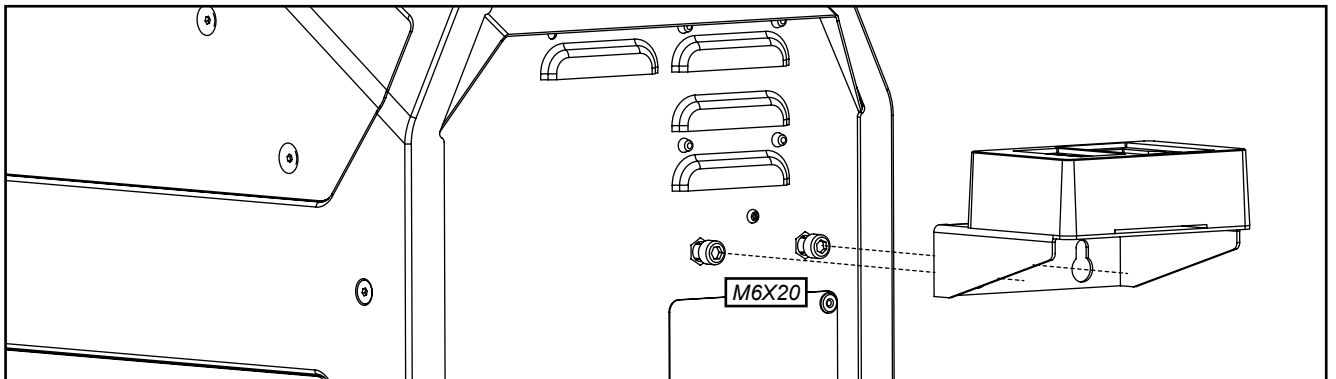
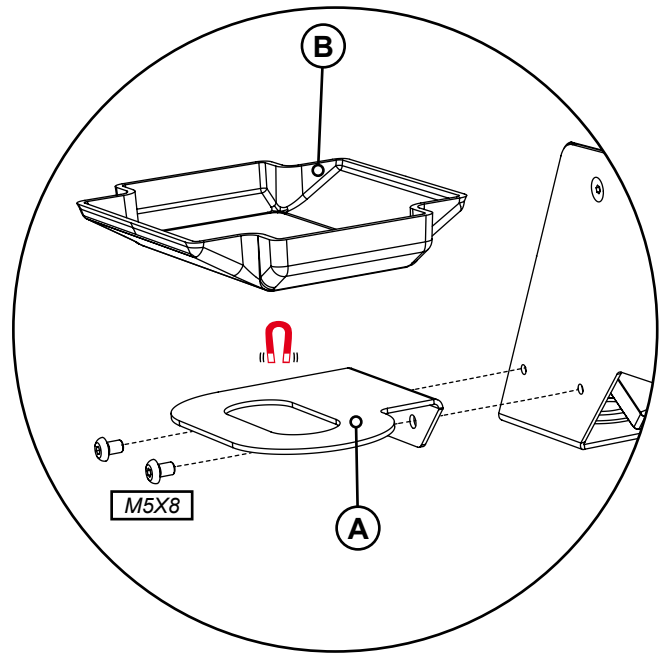

3. PAD MOUNTING TOOL

- The pad mounting tool should be placed on the back of the unit, below the air intakes.
- First, use a 5 mm hex key (included) to loosen (**do not remove them completely**) the two pre-installed M6X20 fixing screws.
- Install the pad mounting tool using the shaped slots. Insert the head of the screws into the widest part of the hole, then push the bracket down to lock.
- Tighten the screws to secure the pad mounting tool.

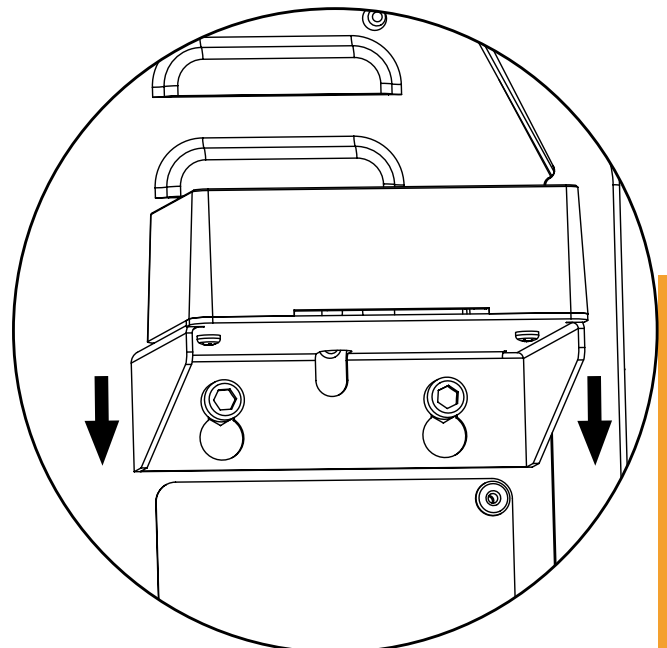

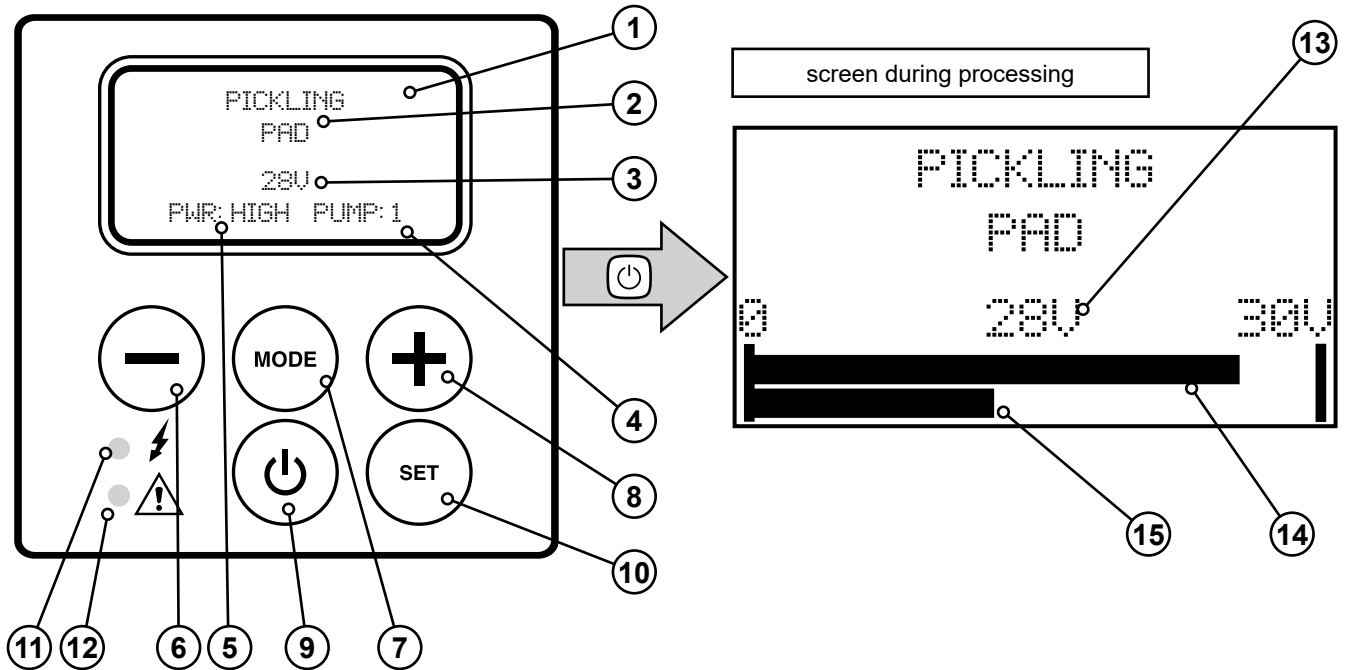

3. CONTROL PANEL

3.1. GENERAL DESCRIPTION



1	Display	9	Power button
2	Operating mode indicator	10	SET button
3	Set voltage (V)	11	Power LED (green)
4	Pump program indicator	12	Alarm LED (red)
5	Device power indicator	13	Set voltage (V)
6	Voltage decrease button	14	Output voltage indicator
7	MODE button	15	Current output indicator
8	Voltage increase button		

3.2. CHANGING THE LANGUAGE

- With the device switched on, keep the – and + buttons pressed at the same time for a few seconds.
- The code 0 0 0 0 will appear on the display; press the  button.
- Select the required language from those available (EN - ES - FR - PT) using the – and + buttons.
- Press the  button again to confirm and go back to the main screen.



If no button is pressed for 30 seconds during the language selection procedure, the unit automatically goes back to the main screen without saving any changes that were made.



3.3. MENU STRUCTURE

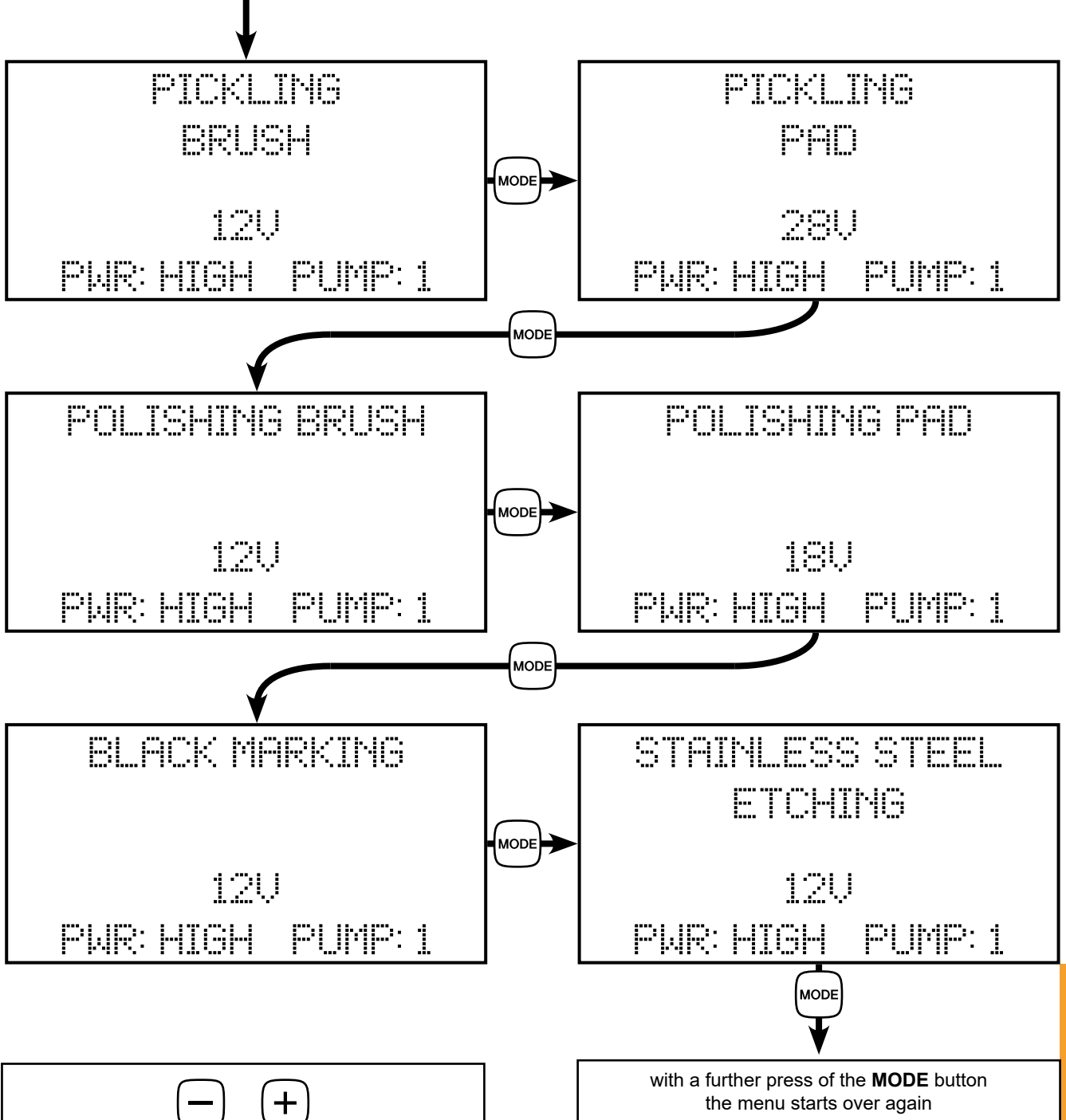

The display lights up when the main switch of the device is brought to position "I"; this switch, colored green, is located in the front of the device (see chapter 2.4). During startup, the **WALTER** logo and a screen with the firmware information are briefly displayed on the screen. The unit then moves on to the PICKLING BRUSH program.

To change the operating mode, press the **MODE** button.



 Regardless of the program selected, the – and + keys can be used to increase or decrease the working voltage (in 1-volt increments).
The default voltage level in the various operating modes is that recommended by the manufacturer.

3.4. POWER ADJUSTMENT

To change the power output of the device, press the **SET** button once and access the configuration screens (see diagram below). Use the – and + keys to choose from the available options.

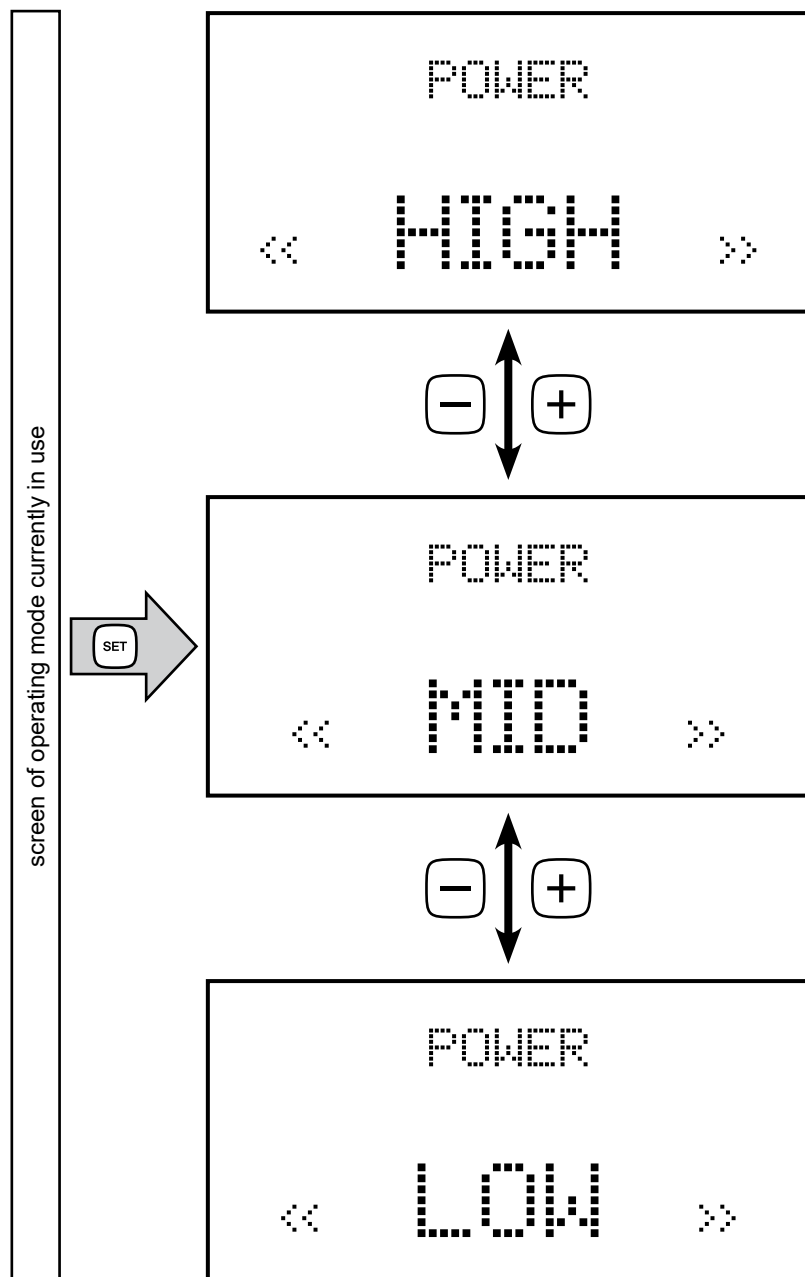

To return to the programme screen, press the **MODE** button.

3.5. PUMP ADJUSTMENT

To change the pump operating modes, press the **SET** button twice and access the configuration screens (see diagram below). Use the **-** and **+** keys to choose from the available options.

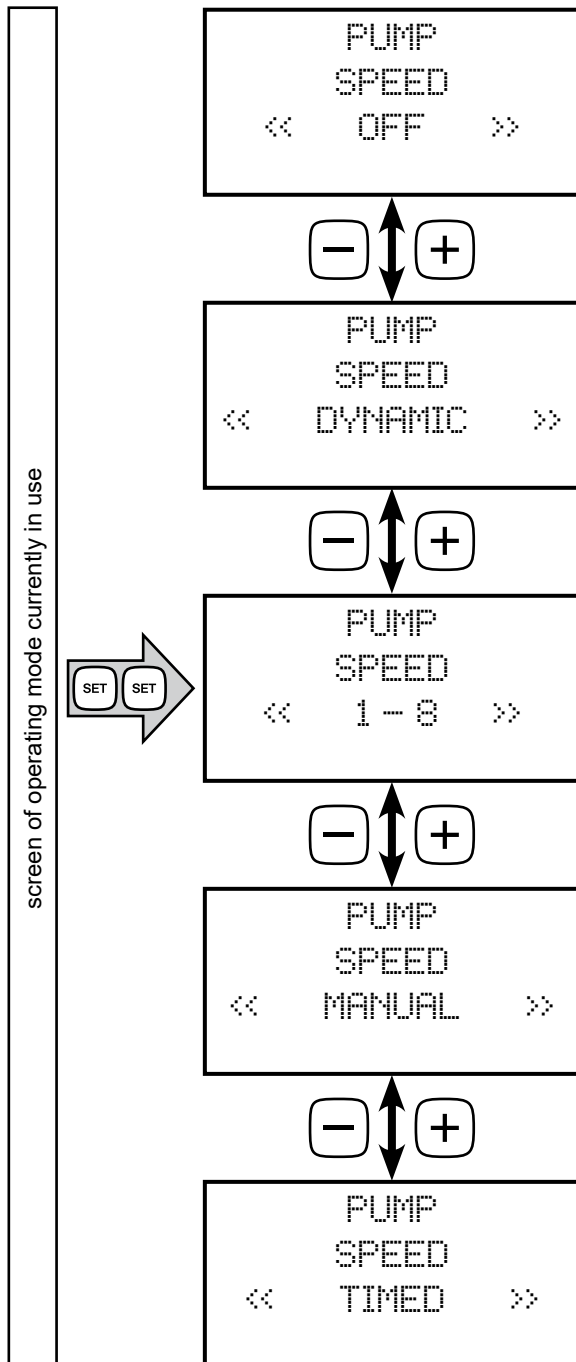

You can completely disable the pump by selecting the **OFF** program.

DYNAMIC mode is a new feature in the SURFOX 306.

When dynamic adjustment is selected, the pump is automatically controlled by the device electronic parts, which decide moment-by-moment how much fluid to transfer to the electrode, based on current consumption during processing.



In this mode, the pump is activated at regular intervals, to push the same amount of liquid towards the electrode. The frequency of activations can be adjusted by selecting one of the **eight available levels**, from 1 (infrequent activation) to 8 (very frequent activation).

In **MANUAL** mode, the pump only activates when the START switch on the wand is pressed (see *chapter 2.4*).

The button must be pressed and held for the pump to start and the electrode must be in contact with the surface to be worked on.

The **TIMED** program is a service mode that activates the pump continuously for about 30 seconds.

This function is useful to quickly fill the hydraulic circuit before processing and to ensure an immediate inflow of liquid to the electrode.

Once this program is selected, activate the pump by pressing the  button on the control panel. The pump stops automatically at the end of the cycle, but you can stop it at any time by pressing  again or the START/STOP switch on the wand.

During the TIMED program cycle, the unit does not supply current.

- **SHORTCUT:** Regardless of the program selected, if you keep the wand STOP switch pressed, the pump will immediately start running in **TIMED** mode. Once the STOP switch is released, the device returns to the previous work setting.

To return to the operation mode screen press the **MODE** button.

3.6. ALARM MESSAGES

In the case of problems or faults, the alarm LED lights up (see *chapter 3.1*) and the device stops supplying current. To help the user identify the source of the problem more easily, the unit displays a text message indicating the probable cause of the malfunction.

After solving the problem, press the **MODE** button to reset the device and resume work.

For further assistance, contact **WALTER Customer Service** (walter.com).

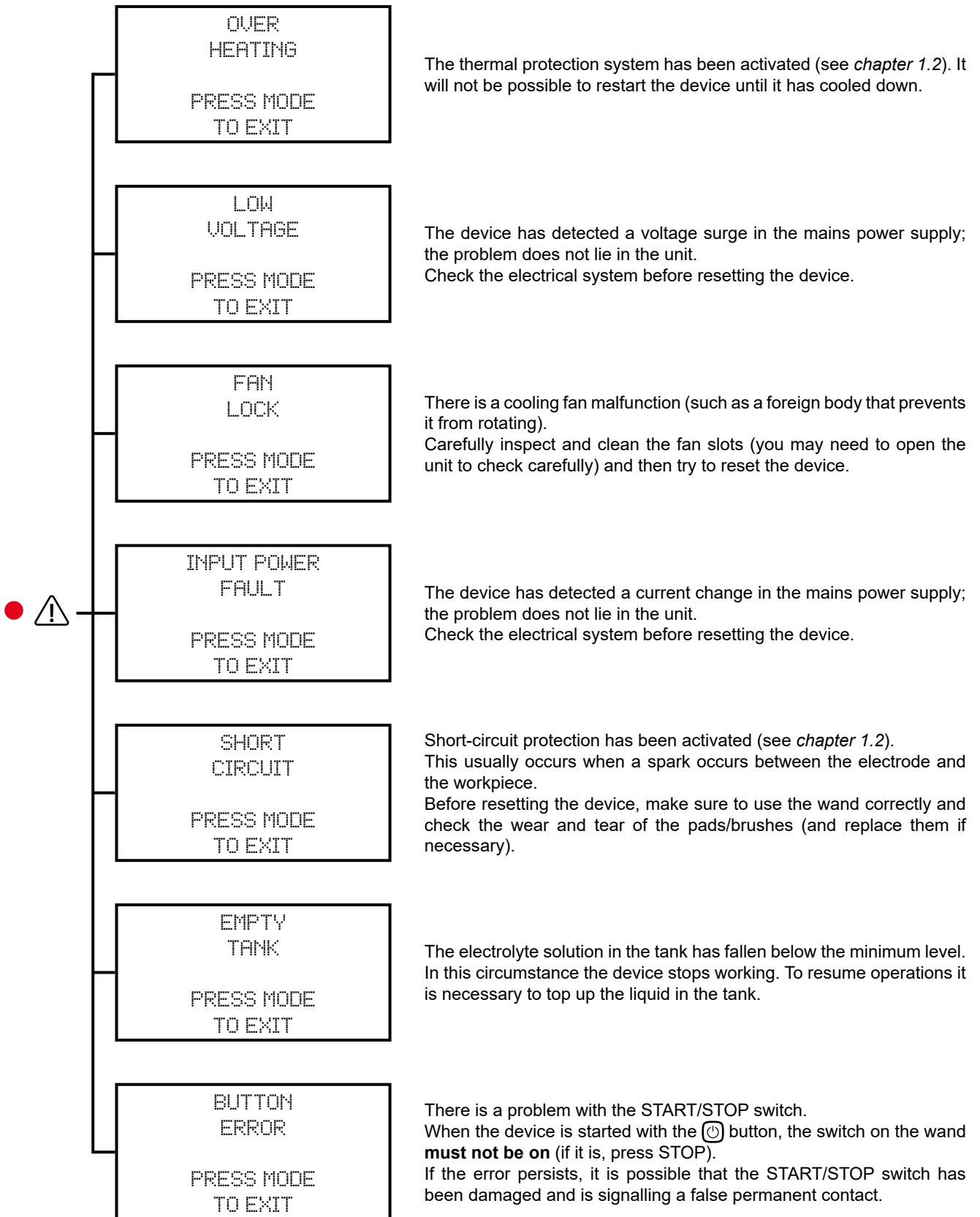

4. MOUNTING ACCESSORIES ON THE WAND



During the installation of inserts, pads and brushes, the device must be switched off:

- Switch the main switch to the "O" position.
- Disconnect the device from the mains.



For its normal operation, the device requires the use of particular acid solutions that can be dangerous (read *chapter 1* carefully).

When replacing an accessory on the wand, **be very careful of any electrolyte residues remaining on the pad or brush.**



Always use suitable protective gloves when mounting/removing wand accessories in order to:

- Reduce the risk of direct contact between skin and acid solutions.
- Obtain a certain level of protection from burns if the inserts are still too hot.

4.1. OVERVIEW OF ACCESSORIES

BRUSHES

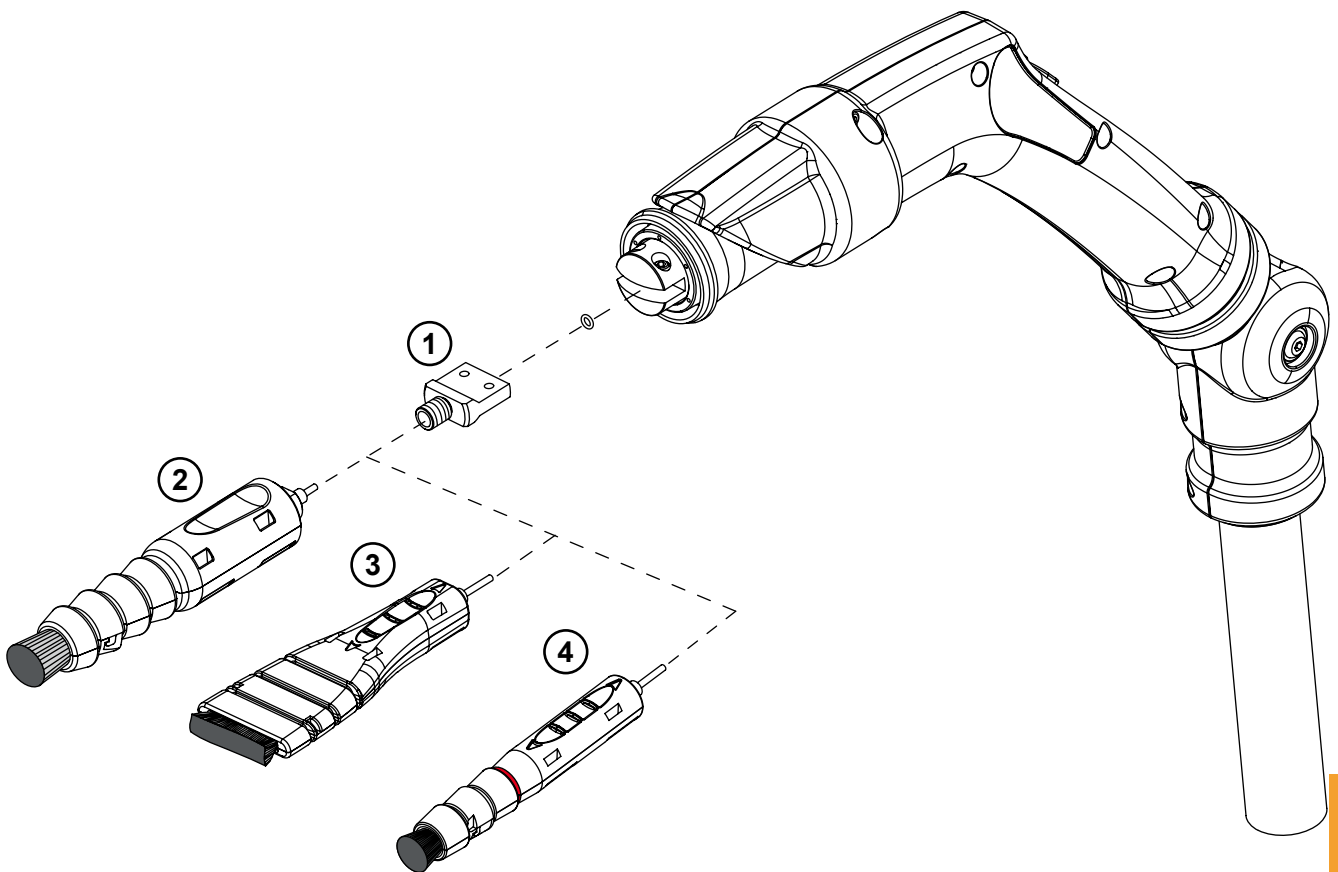

1	54-B 149	Brush adaptor	included	p. 20
2	54-B 606	Round shape brush (Ø12)	included	p. 21
3	54-B 155	Triangular shape brush	optional	p. 21
4	54-B 601	Round shape brush (Ø10)	optional	p. 21

INSERTS

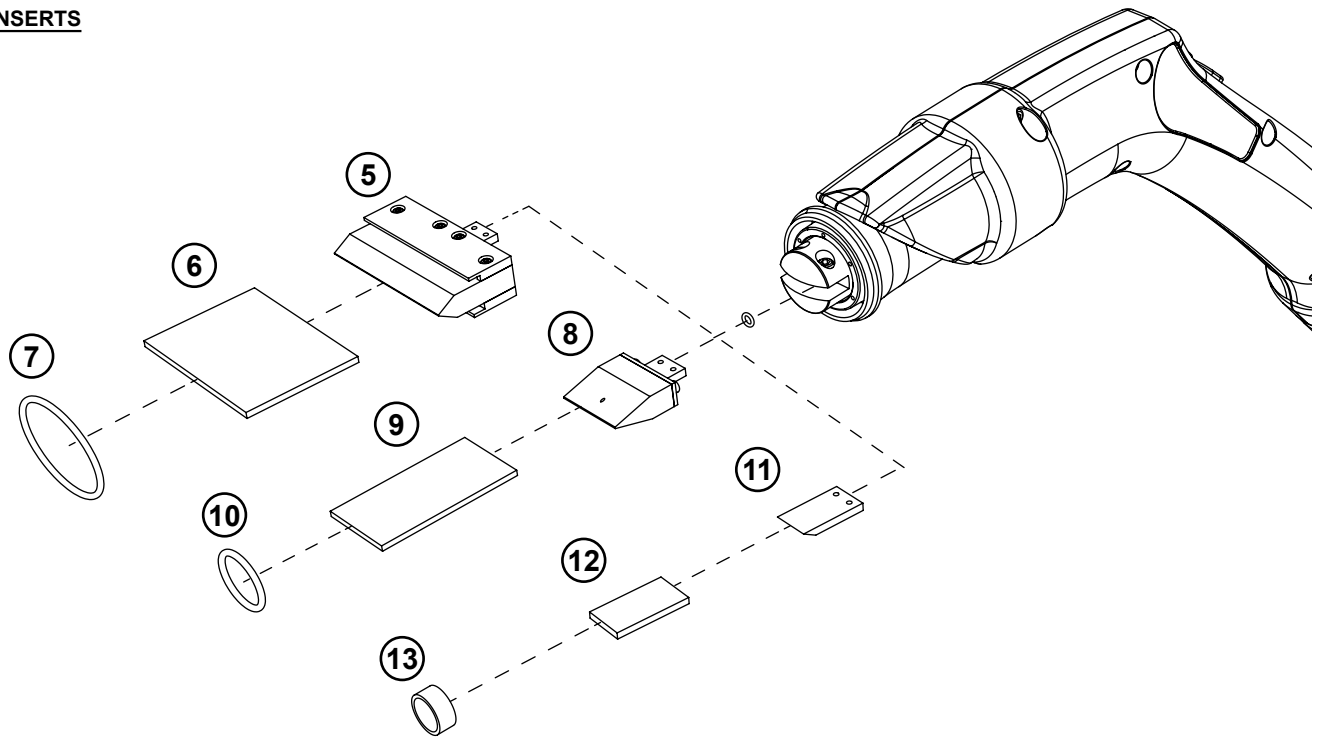

5	54-B 607	Graphite insert 100 mm	optional	p. 22
6	54-B 608	SURFOX cleaning pad for graphite insert 100 mm	optional	p. 22
7	54-B 609	O-ring for graphite insert 100 mm	optional	p. 22
8	54-B 009	Graphite insert 45 mm	optional	p. 22
9	54-B 043	SURFOX cleaning pad for graphite insert 45 mm	optional	p. 22
10	54-B 180	O-ring 30 x 3.5	optional	p. 22
11	54-B 143	Tungsten insert 22 mm	optional	p. 23
12	54-B 026	Standard cleaning pad	optional	p. 23
13	54-B 002	PTFE clamp ring for standard cleaning pads	optional	p. 23

WALTER Customer Service (walter.com) is available for any additional information.

4.2. INSTALLATION OF BRUSH ADAPTOR / INSERTS

- Take the brush adaptor **54-B 149** or the desired insert.
- In the back of the adaptor (or insert) there are the two countersinks (A) where the wand coupling set screws will be tightened.
- Before positioning the adaptor (or insert) on the wand coupling, **make sure that the 48-R 113 O-ring seal is in place (B)**.
- Place the adaptor (or insert) on the wand coupling and tighten the two set screws with a 2.5 mm hex key (C) (included); make sure the set screws are properly aligned with the countersinks (A).

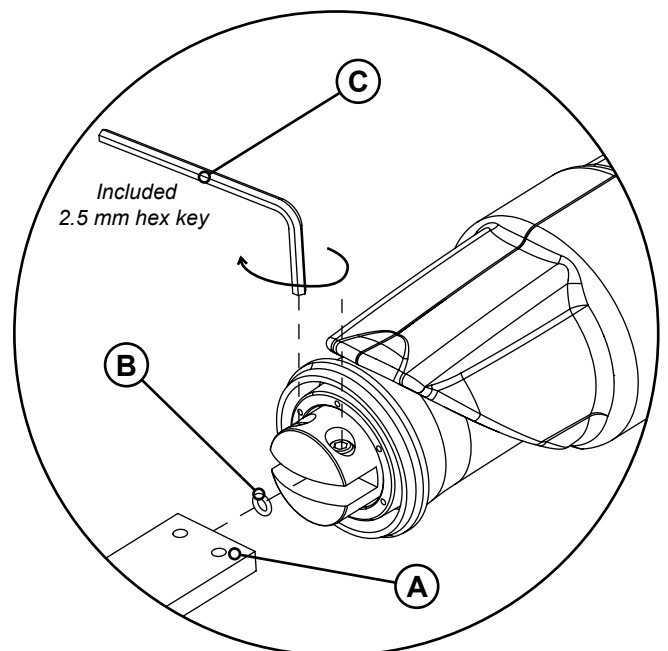

4.3. MOUNTING BRUSHES

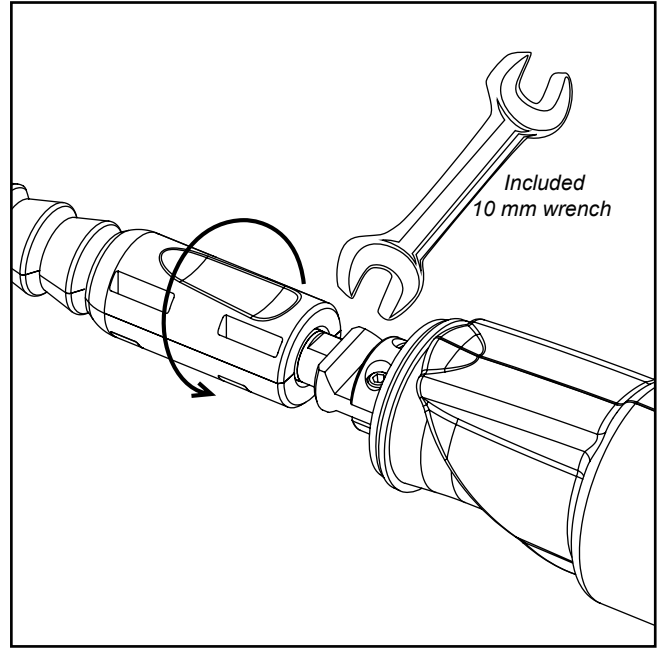
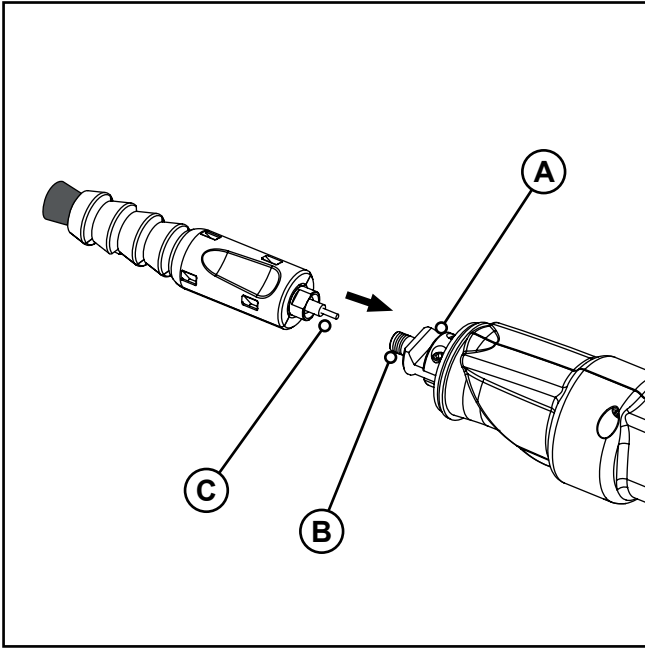

- Install the brush adaptor (A) on the wand (see chapter 4.2).
- The adaptor is equipped with a threaded coupling (B) on which to screw the brush.
- Screw the brush onto the threaded coupling; be careful when threading the end of the brush tube (C).
- When installing the Ø12 round shape brush **54-B 606**, use the 10 mm wrench (included) to tighten the brush firmly onto the adaptor thread. The brush coupling segment is shaped (D) for easy grip with the wrench.
- When using the triangular shape **54-B 155** or the Ø10 round shape **54-B 601** optional brushes, the installation on the adaptor can be done by a simple screwing of the two parts by hand (E) (F).
- If necessary, adjust brush bristle length (see chapter 4.7).

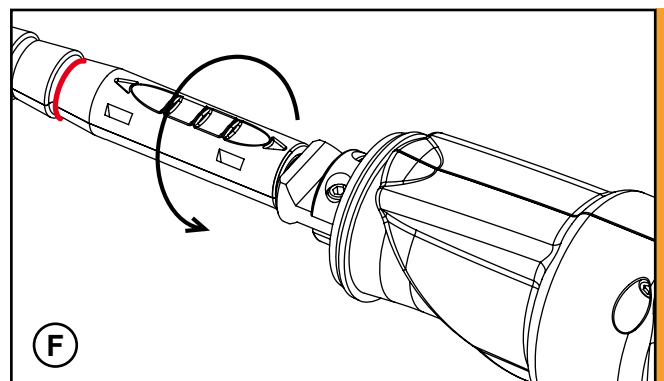
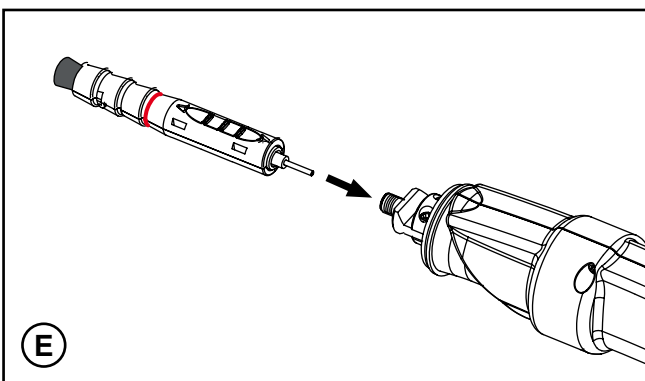
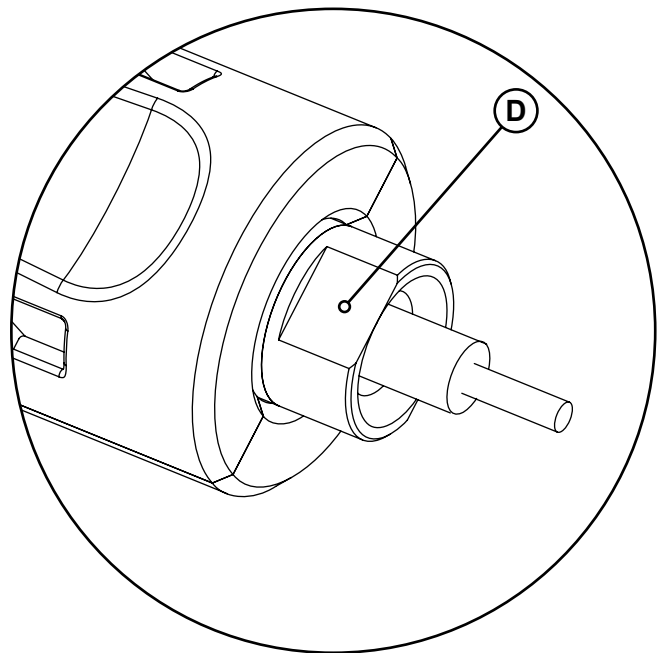

4.4. MOUNTING PAD ON GRAPHITE INSERT 100 mm

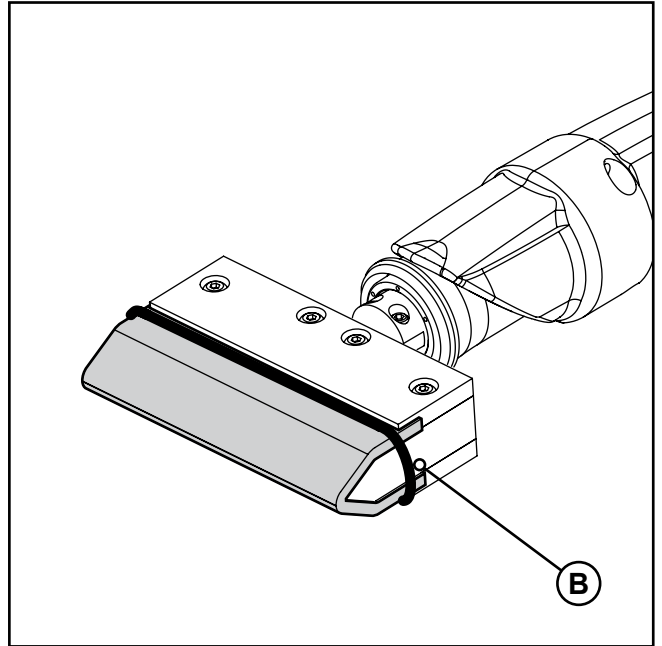
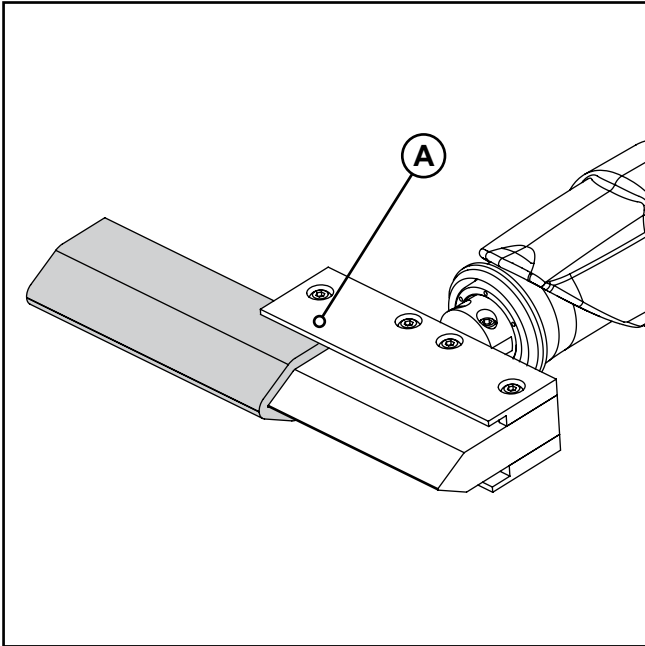

- Install the **54-B 607** insert on the wand (see *chapter 4.2*).
- Fold the **54-B 608** pad into a "U" shape and slide it into the fins with grooves (A) on the electrode.
- Fasten the pad in place using the **54-B 609** O-ring (B).
- Adjust the insert direction as needed (see *chapter 4.8*).

4.5. MOUNTING PAD ON GRAPHITE INSERT 45 mm

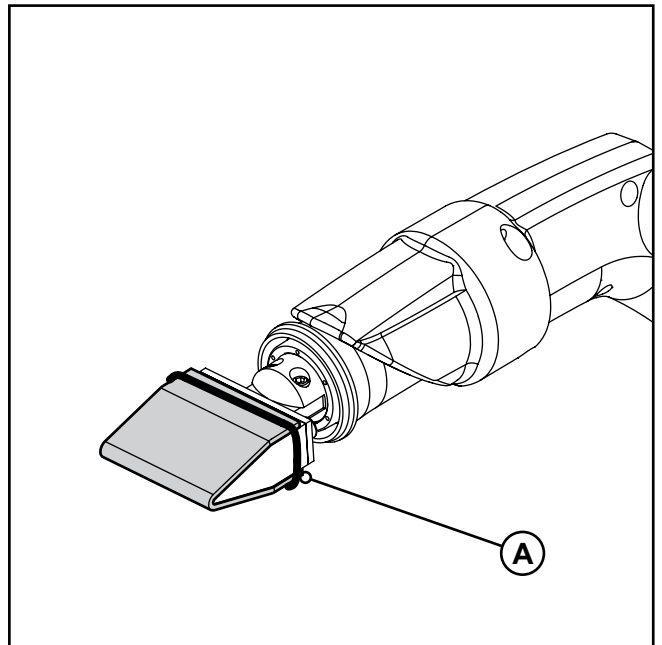
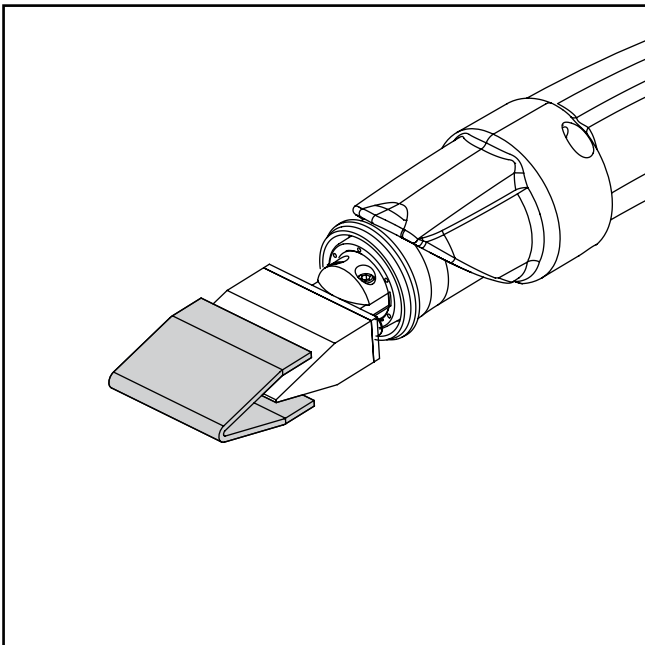

- Install the **54-B 009** insert on the wand (see *chapter 4.2*).
- Fold the **54-B 043** pad into a "U" shape and stick it on to the electrode.
- Fasten the pad in place using the **54-B 180** O-ring (A).
- Adjust the insert direction as needed (see *chapter 4.8*).

4.6. MOUNTING PADS WITH PTFE CLAMP RING

In some types of inserts (e.g. **54-B 143**), the pad is fixed using a PTFE clamp ring (e.g. **54-B 002**). In these cases, the pad mounting tool on the back of the device is used for assembly (refer to *chapter 2.4*).

- Install the insert on the wand (see *chapter 4.2*).
- Insert the clamp ring (C) into the special oval slot of the pad mounting tool (A). To do this, apply a light pressure with your fingers to the two opposite sides of the ring so that it takes on an elliptical shape, then position it in place.
- Place the **54-B 026** pad (D) in the rectangular groove of the pad insertion tool (B).
- Take the wand and push the tip on the pad insertion tool so that the pad and the ring both fit onto the electrode.
- Adjust the insert direction as needed (see *chapter 4.8*).

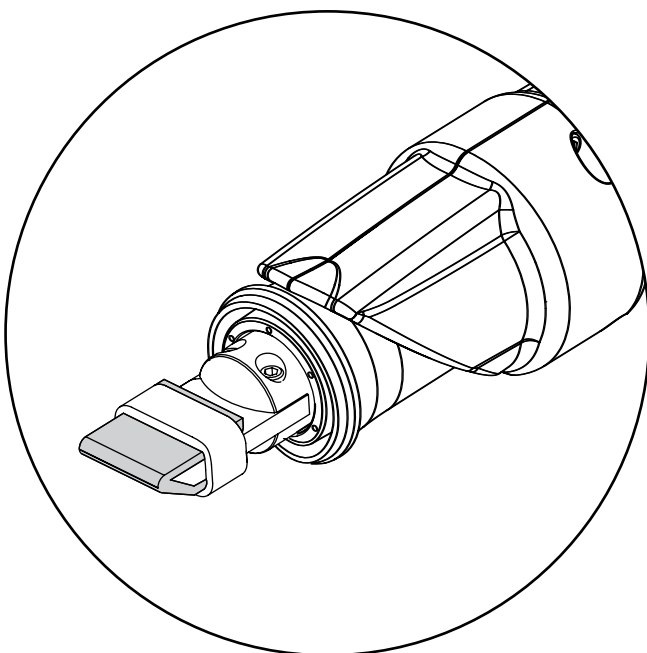
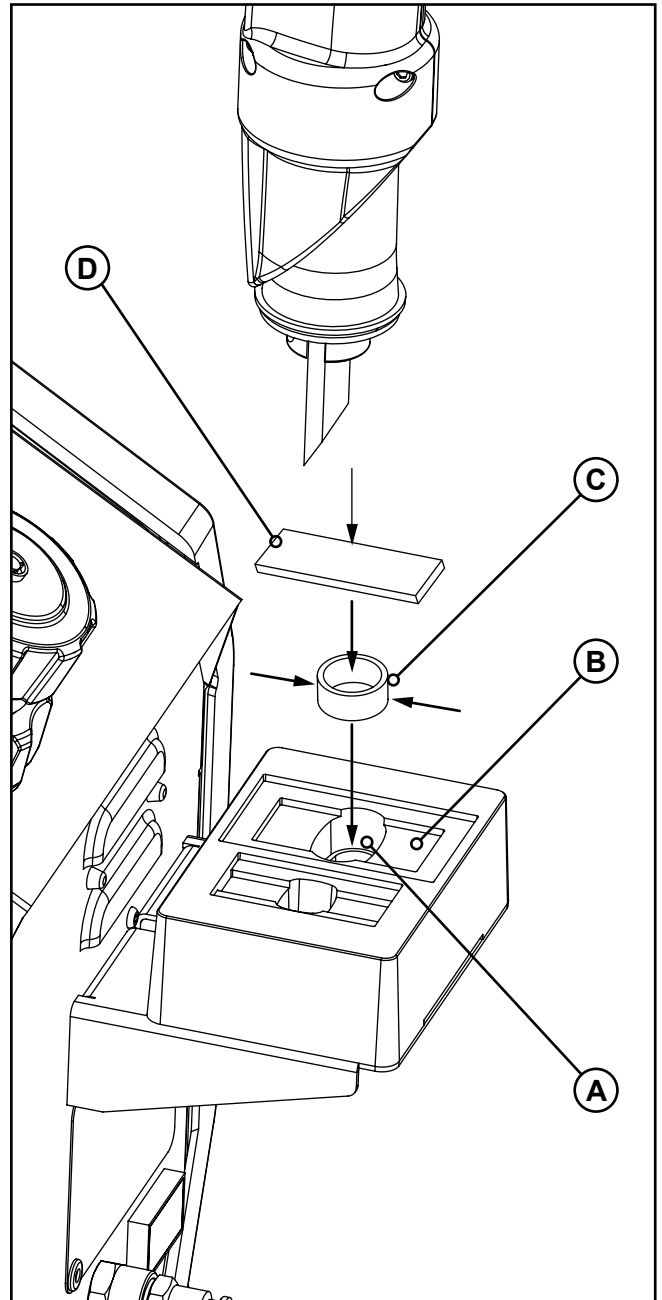

4.7. BRUSH BRISTLE LENGTH ADJUSTMENT

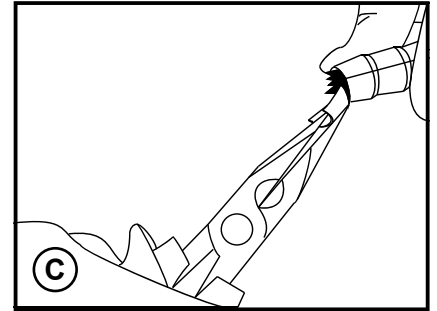
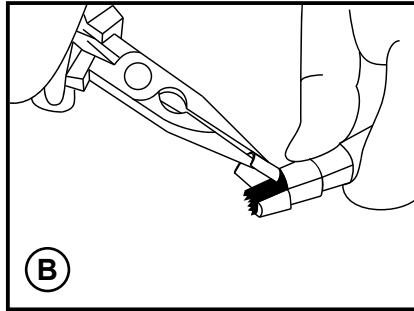
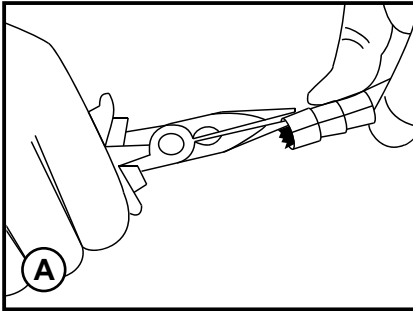

- The SURFOX 306 brushes are made up of segments that must be gradually removed as the bristles wear out.

54-B 606	4 segments
54-B 155	3 segments
54-B 601	3 segments
- Once the bristles are worn down, use long nose pliers to remove the first segment (A).
- Insert the long nose into the sleeves and lift up the top part of the sleeve (B).
- Do the same with the other half (C).



For an optimum performance and a better durability of the brush, thoroughly saturate the fibers and perform the cleaning of the welds with sufficient amount of electrolyte solution. Rinse the brush with water and neutralize with Surfox-N after use.

4.8. DIRECTION OF INSERTS

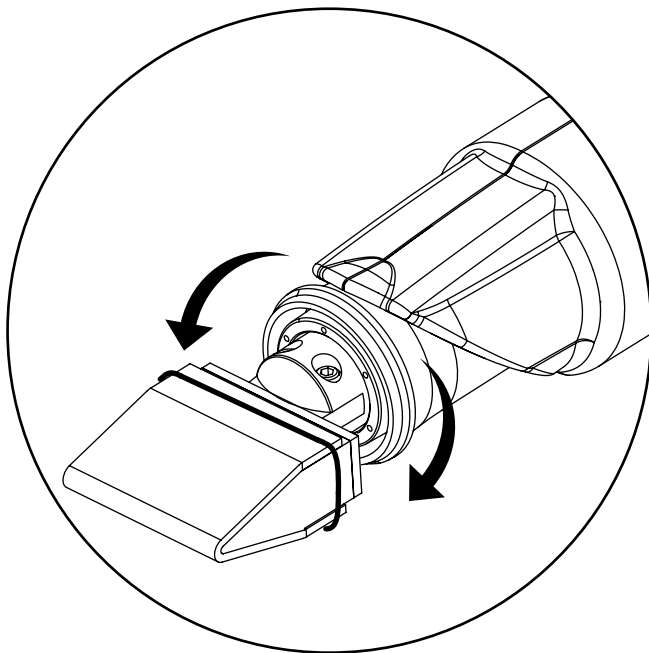

To facilitate processing when the surfaces to be treated have particular shapes or are located in places that are difficult to access, it is possible to adjust the wand coupling to arrange the insert in a more comfortable position. The insert can be rotated about $\pm 90^\circ$ with respect to the horizontal position.

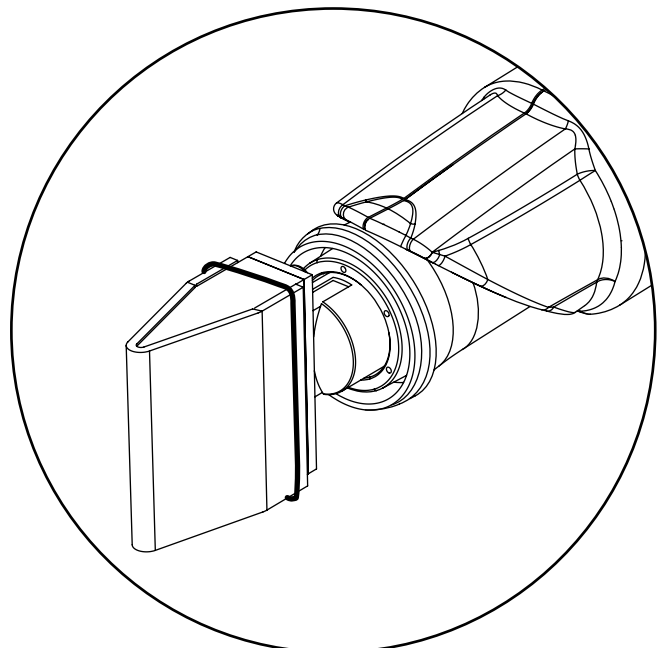

The electrodes reach very high temperatures during the processing operations.

If it is necessary to change the orientation of the insert, take care to prevent burns to the hands.

5. BEFORE DEVICE STARTUP

5.1. PRECAUTIONS FOR THE USE OF THE DEVICE

To avoid damage to the device, check that:

- The mains voltage corresponds to that supported by the unit (as specified in the technical data and rating plate).
- The surface to be treated is connected to ground with a cable of appropriate thickness.
- All sockets, connectors and cables used with the device are in good working order.
- The electrical system to which the unit is connected is equipped with protection devices against short circuits and current surges. These safety systems must be fully operational.
- The workstation where the device is used must always be kept clean and tidy.
- After processing or during breaks, the clamp for earthing the workpiece or work surface is deactivated.

In working environments where there are both welding and pickling stations:

- Do not weld and clean/polish the same workpiece at the same time.
- Disconnect the ground cable from the device during any welding operation.



If the operator uses a welding machine while both earthing cables are connected to the surface being processed, the electrical components of the device may be damaged even if the welding torch does not come into contact with the workpiece. In particular, the internal components of the device could be subjected to a high voltage of up to 100 V.

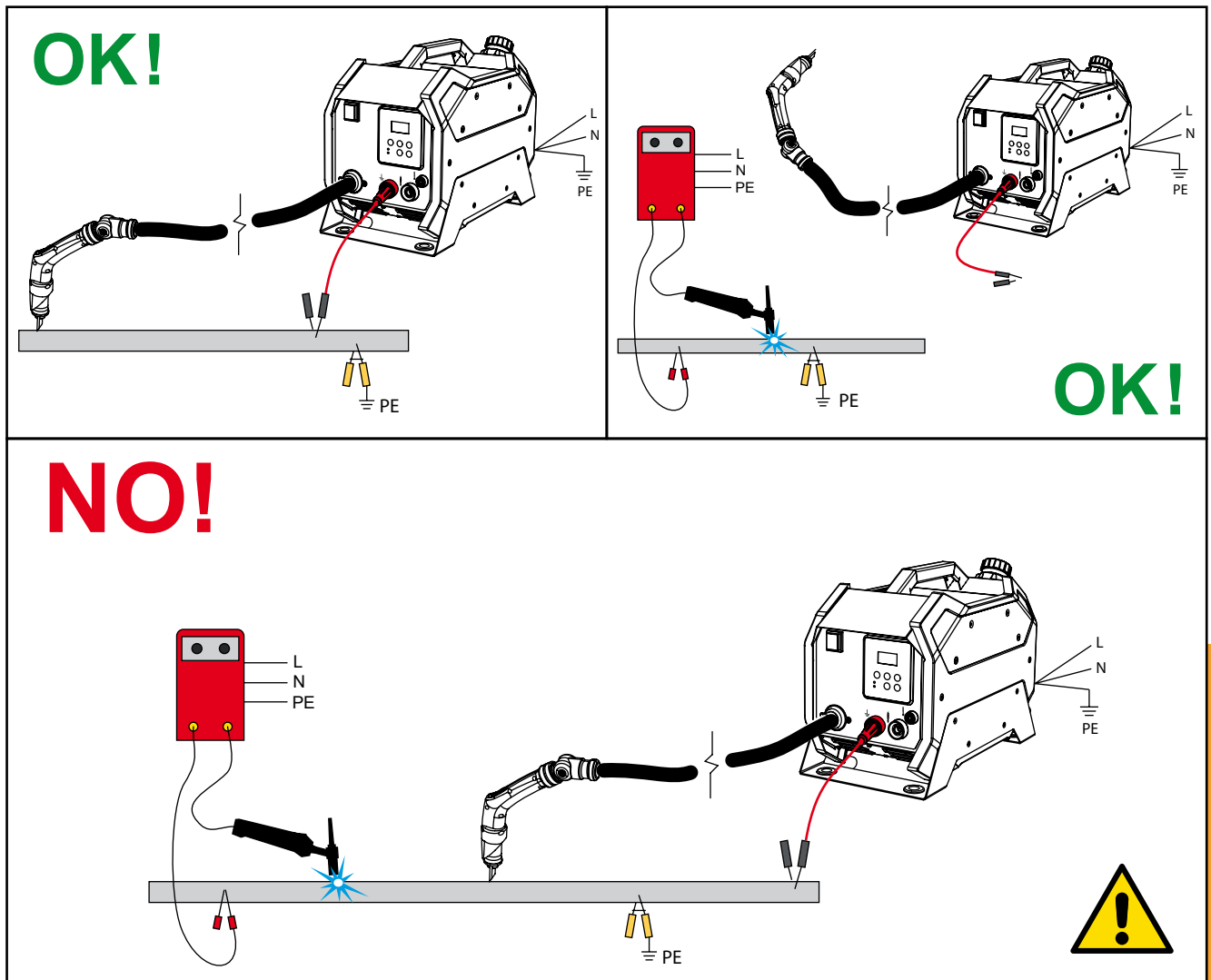

5.2. FILLING THE TANK

- Make sure that the device is resting firmly on a flat, level surface.
- Remove the tank cap (A).
- Pour in about 1.8 l of electrolyte solution; **the level of the liquid must never reach the brim.**



Acid solutions can be harmful to people and the environment, so during the tank refilling operations, take all the precautions described in *chapter 1*.
In particular, take care not to spill the electrolyte outside the tank.

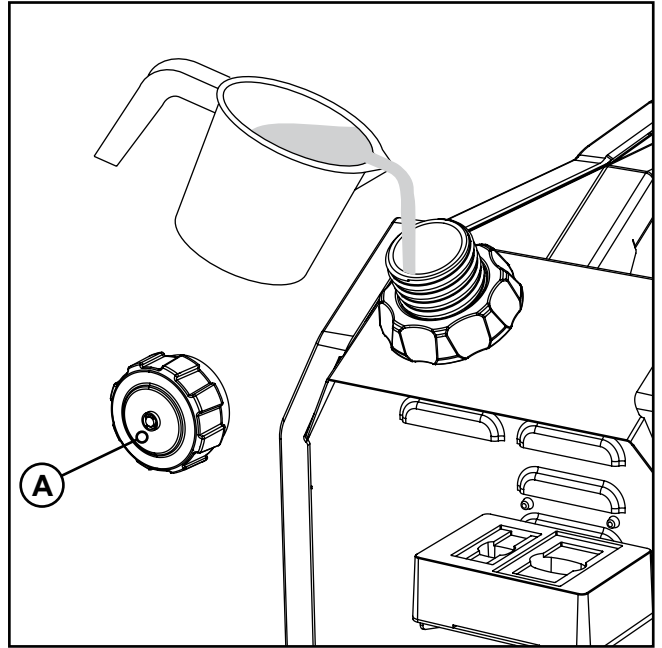



5.3. CONNECTION TO THE COMPRESSED AIR CIRCUIT

- Take the compressed air terminal (A) and fit it onto the appropriate connector (B) on the back of the unit.

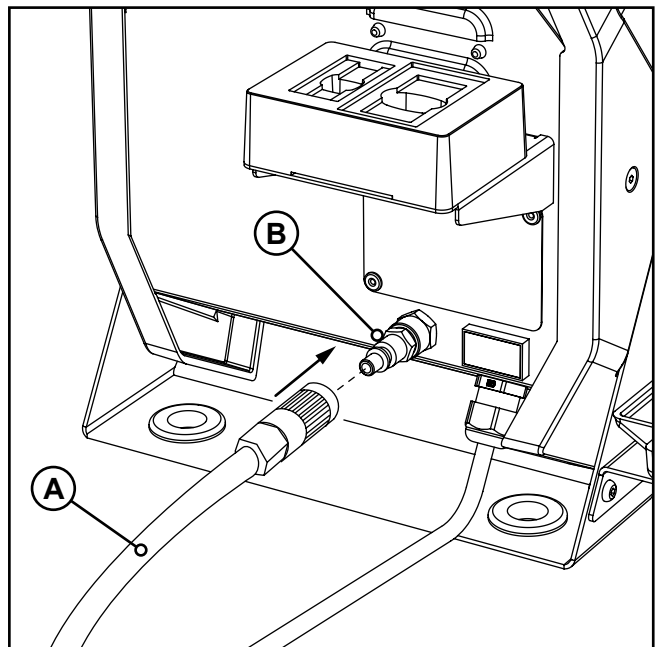

The characteristics of the compressed air circuit must be **strictly** as follows:

- Operating pressure 150 PSI.
- Flow of dried air.





If it is not possible to connect the device to a compressed air circuit, the fume abatement system built into the device shall not come into operation.

5.4. ELECTRICAL INSTALLATION

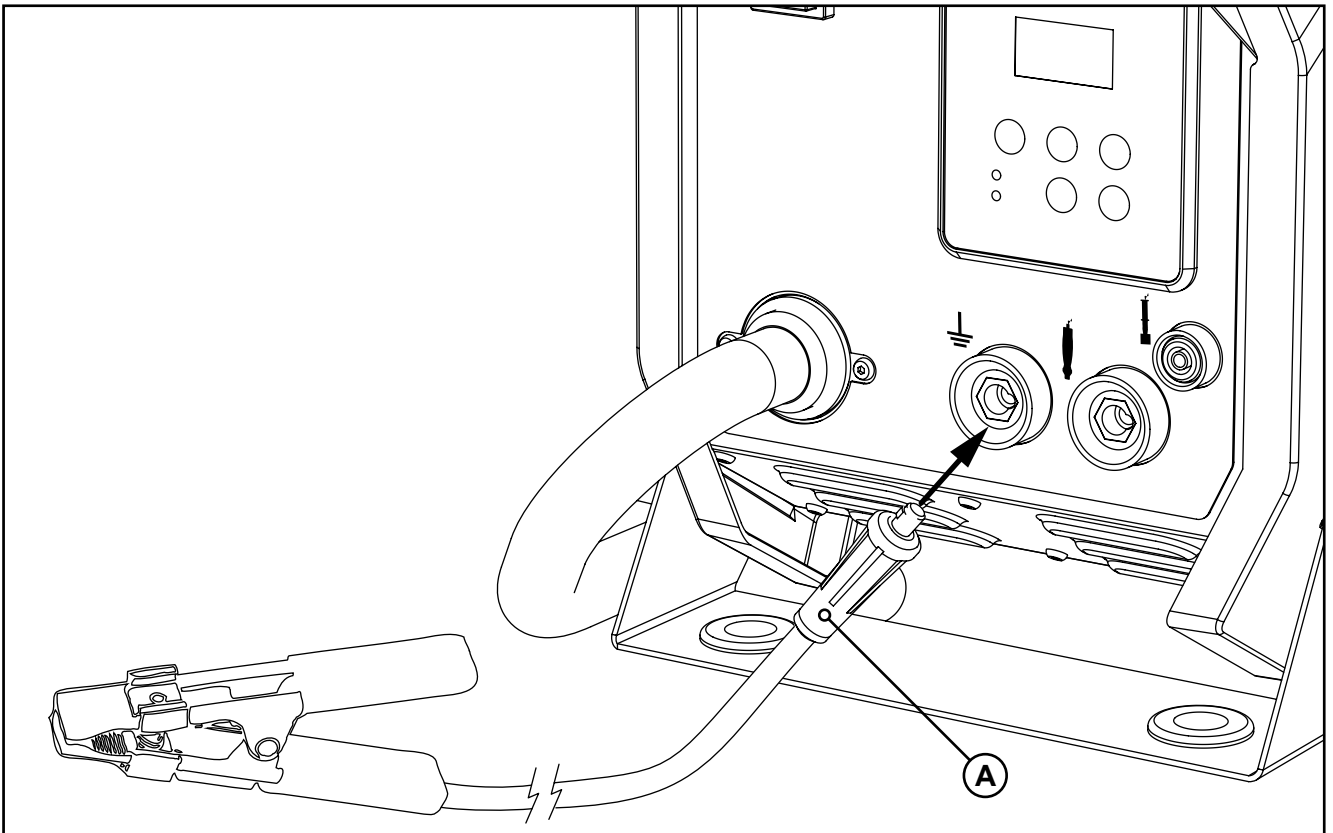

Make sure you have read and checked all the precautionary notes in *chapter 5.1*.



- Prepare the wand by installing the most suitable accessory for the type of work you want to undertake (see *chapter 4*).
- Connect the ground cable connector (A) to the red socket on the front panel of the unit.
- Use the crocodile terminal of the ground cable (B) to grip the piece of stainless steel to be treated.
- Connect the device power cord to a suitable socket.

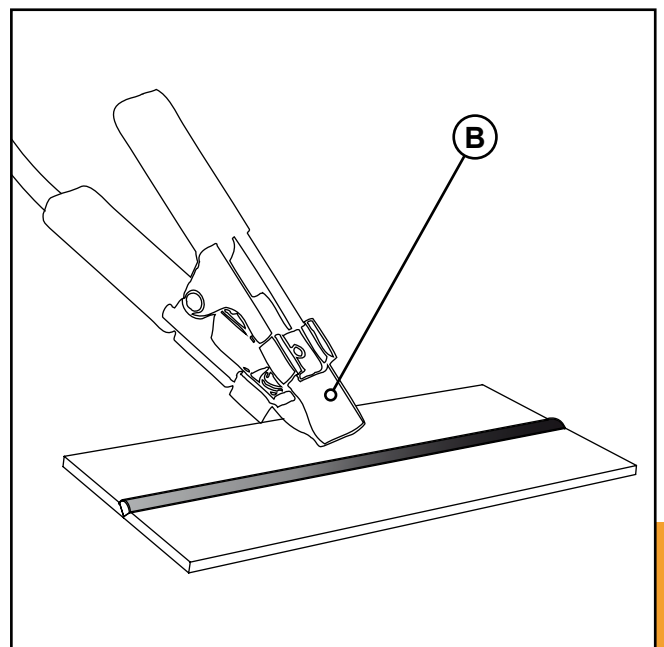

6. CLEANING AND POLISHING OF WELDS

6.1. START OF PROCESSING

Before starting to pickle / polish a piece of stainless steel, check that all the preliminary operations described in *chapter 5* have been carried out correctly.

For its normal operation, the device requires the use of special electrolyte solutions.

It is very important to choose the most appropriate liquid for the type of processing to be carried out:

- **SURFOX-T**, an heavy-duty cleaning solution suitable for both pickling and polishing.
- **SURFOX-G**, a pH neutral cleaning solution suitable for pickling only.

Always refer to the product data sheet for detailed indications regarding its field of use.

WALTER Customer Service (walter.com) is available for any additional information.



Acid solutions are dangerous and can cause damage to people and property: read the *chapter 1* carefully for safety precautions and personal protective equipment to use when working with these substances.

- Make sure that the desired electrolyte solution type is in the tank and that the quantity is adequate for the type of processing you are about to start; if necessary, top up the tank.
- Make sure the most appropriate accessory is installed on the wand for the type of processing to be performed.
- Turn on the device by turning the main switch (located on the front panel of the unit) to the "I" position.
- Select the desired operating mode by pressing the **MODE** button on the control panel (see *chapter 3.3* for more information).
- Press the **SET** button to select the desired power level (see *chapter 3.4* for more information).

In order not to cause excessive wear or damage to the accessories, it is recommended that you select the power level according to the following table, which takes into account both the power supplied by the SURFOX device model used, and the conductivity of the electrolyte solution.

ACCESSORY	PART No	SURFOX-T	SURFOX-G
Round shape brush (Ø12)	54-B 606	HIGH	HIGH
Triangular shape brush	54-B 155	LOW	LOW
Round shape brush (Ø10)	54-B 601	LOW	LOW
Graphite insert 100 mm	54-B 607	MID	HIGH
Graphite insert 45 mm	54-B 009	LOW	MID
Tungsten insert 22 mm	54-B 143	LOW	MID

The table is to be considered valid only if the manufacturer's predefined voltage values are used in the various operating modes.

- Press the **SET** key twice to set the pump operating mode (see *chapter 3.5* for more information).



If you are using the device for the first time after purchase, please remember that the hydraulic circuit is tested at the factory using a special non-conductive liquid. For this reason, before processing, it is always advisable to operate the pump for about 1 or 2 minutes to ensure that the entire hydraulic circuit has been filled exclusively with the electrolyte solution.

Use the TIMED program to facilitate this operation. During this procedure, carefully observe the liquid released by the brush/electrode and deactivate the pump only when there is no more residual test fluid visible.

- Press and hold the STOP button on the wand switch to force pump activation and make sure that the pad or brush is properly moistened with the electrolyte solution before starting processing.



If the electrode is not in contact with the surface to be treated (i.e. there is no current), the pump stops working regardless of the operating mode selected; this prevents the electrolyte solution from being wasted unnecessarily.

The only way to force the liquid out, even if there is no current flow, is to use the TIMED program or hold down the STOP button on the wand switch.

- Press the START button on the wand switch (or alternatively the  button on the control panel) to start the device. The fume abatement system comes into operation.



Once started, the device switches off automatically after approximately 30 seconds of inactivity.

This is a precautionary measure to prevent the wand from being accidentally powered at the end of processing.

UTILIZATION OF THE INDICATORS ON THE DISPLAY

During processing, bar indicators appear on the display showing in real time the voltage and current supplied by the device (see *chapter 3.1*). When the workpiece is not being touched, no current passes through the wand and the voltage is maintained at half the set voltage. The voltage only starts to rise gradually when work actually starts, thus minimizing the likelihood of arcing or sparking at the point of contact between the brush/insert and the weld to be cleaned/polished.

- Start cleaning/polishing by positioning the brush/pad on the stainless steel workpiece.
- Pass the brush/pad over the weld by applying light pressure and continue the process until each sign of oxidation is completely removed. Sparks and foam may form at the contact point between the brush/pad and the weld during processing. This is perfectly normal.
- If necessary, use the – and + buttons on the control panel to adjust the output voltage and to obtain better results (if you change operating mode, the voltage returns to the default level preset by the manufacturer).

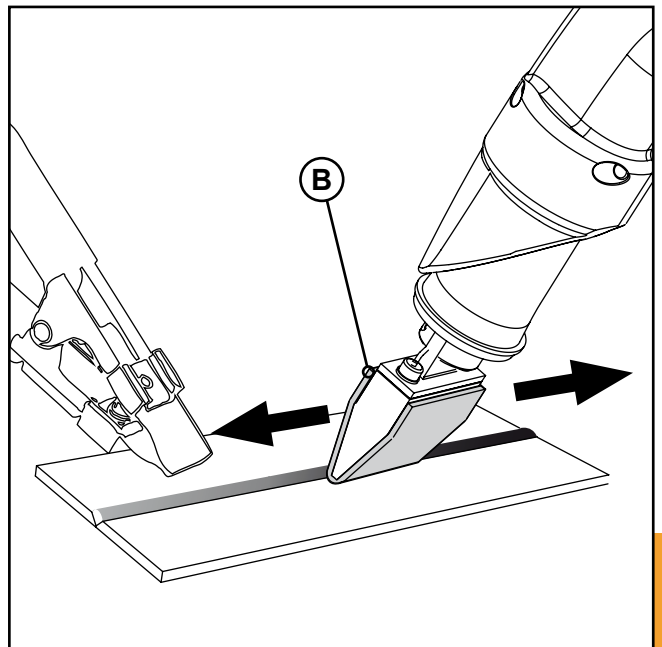
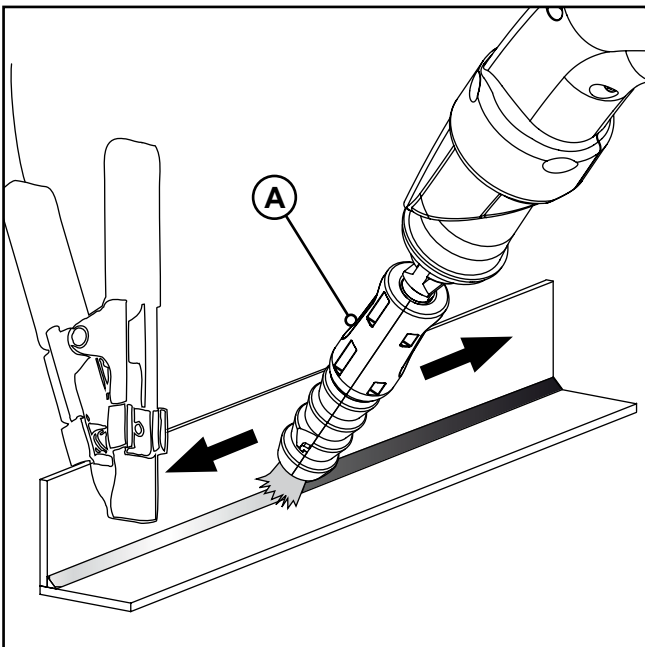

- Brushes (A) are suitable for hard-to-reach welds, while pads (B) are particularly suitable for large welds.



- The polishing process requires a greater amount of electrolyte solution than pickling.
- Always keep the brush/pad well moistened with the electrolyte solution to avoid overheating and a consequent significant reduction in its working life; if there are obvious signs of wear, replace the component immediately.
- If the power and/or voltage is increased during processing, the electrolyte solution evaporates faster; compensate for the evaporation of the liquid by increasing the pump speed (in dynamic mode this is not necessary; see *chapter 3.5* for more details).
- Never use an insert without its matching pad; the insert must never be placed in direct contact with the steel workpiece.
- When cleaning/polishing, keep the brush perpendicular to the weld and never press the carbon bristles excessively against the surface to be treated (C).
- For best results, adjust the brush bristle length as needed (see *chapter 4.7*).

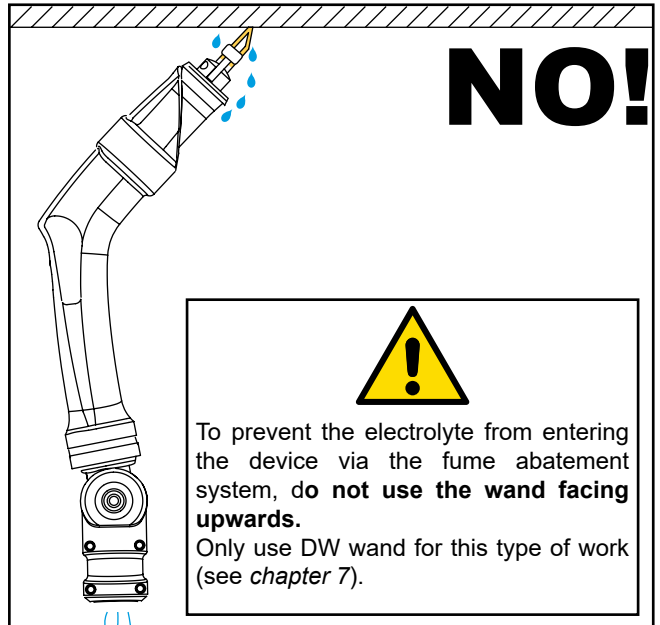
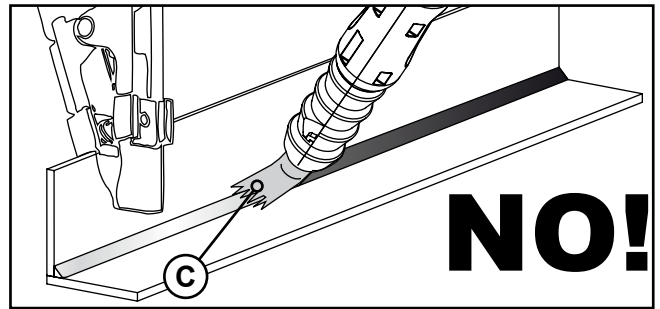

6.2. AFTER PROCESSING

- Press the STOP button on the wand switch (or alternatively the  button on the control panel) to stop the current supply to the wand and stop the fume abatement system.
- Put the wand back in its holder (A).



At the end of processing, always store the wand and other accessories appropriately. Never place the wand on top of the device during breaks or at the end of processing, as the electrolyte solution could drip from the dampened brush/pad and penetrate inside the unit. Always use the appropriate holder and empty the collection tray when necessary. The device should in any case be kept as clean as possible.

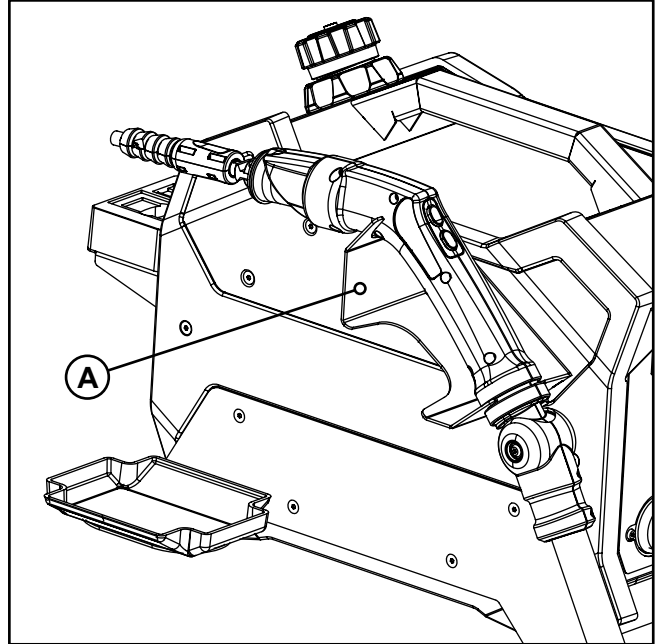

- Disconnect the ground cable crocodile clip from the machined part.
- Wipe out excess of electrolyte solution with a microfiber cloth **54-B 090**.
- Use the SURFOX-N solution on the treated piece.



It is very important to spray the SURFOX-N solution on the workpiece; this product neutralizes any residual electrolyte, thus avoiding the formation of halos and white spots (which can only be eliminated by repeating the entire process). Alternatively, it is possible to clean the surface with an abundant jet of water.

- Rub the surface with a microfiber cloth **57-M 001**.
- Dry the surface using a dry microfiber cloth.

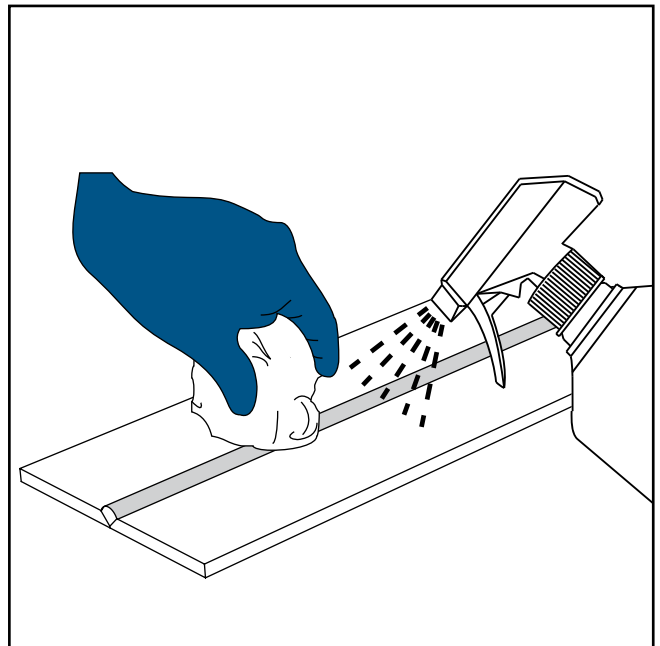

6.3. SHUTDOWN

- Turn off the device by turning the main switch to the "O" position.
- Disconnect the unit plug from the power supply socket.
- Carry out routine maintenance on the device as described in *chapter 9.1*.
- To limit any environmental impact, used pad and used liquids must always be disposed of in accordance with current waste disposal regulations (see *chapter 10* for additional information).

7. DW WAND (OPTIONAL)

7.1. OVERVIEW OF DW WAND ACCESSORIES

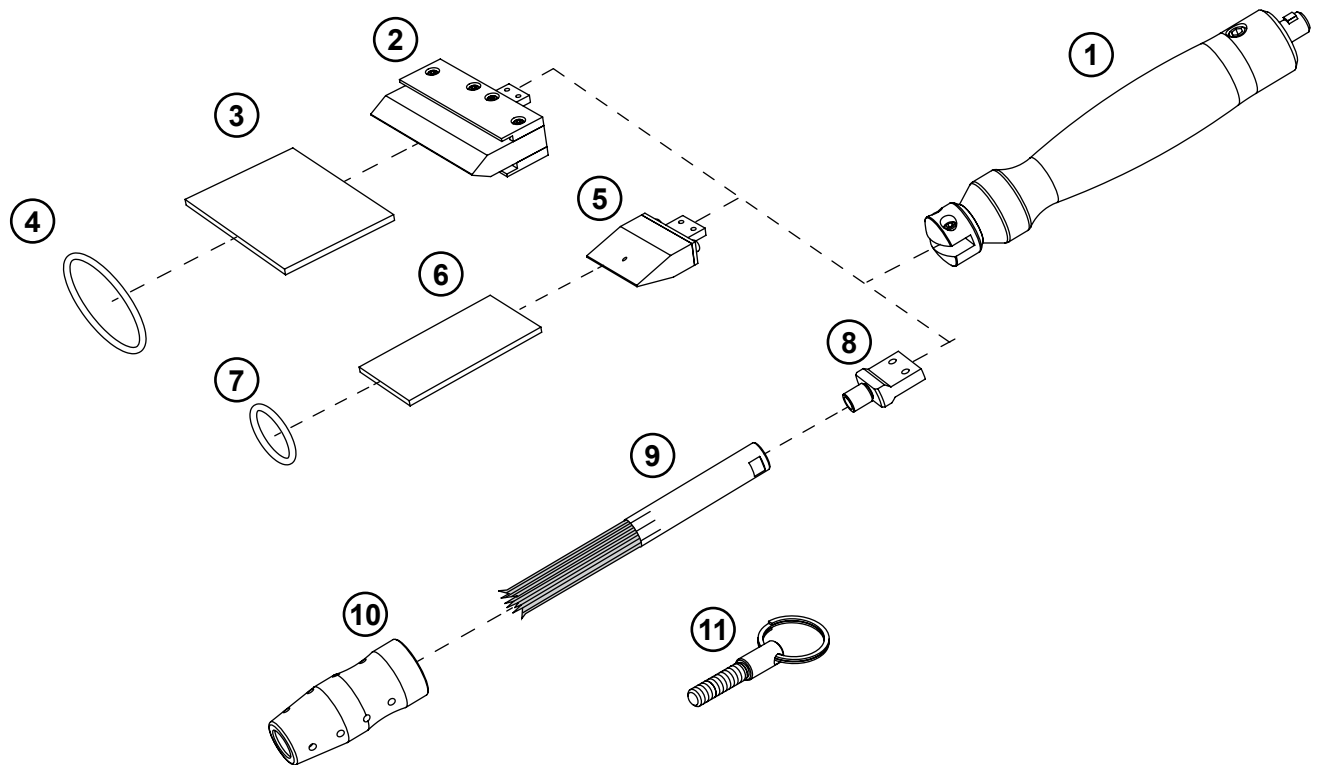

1	54-B 617	DW wand	optional	p. 32
2	54-B 607	Graphite insert 100 mm	optional	p. 33
3	54-B 608	SURFOX cleaning pad for graphite insert 100 mm	optional	p. 33
4	54-B 609	O-ring for graphite insert 100 mm	optional	p. 33
5	54-B 009	Graphite insert 45 mm	optional	p. 34
6	54-B 043	SURFOX cleaning pad for graphite insert 45 mm	optional	p. 34
7	54-B 180	O-ring 30 x 3.5	optional	p. 34
8	54-B 149	Brush adaptor	optional	p. 33
9	54-B 604	DW brush for S306	optional	p. 35
10	54-B 605	DW sleeve	optional	p. 35
11	54-B 618	Brush extraction tool	optional	p. 35

WALTER Customer Service (walter.com) is available for any additional information.

7.2. INSTALLATION OF INSERTS / BRUSH ADAPTOR



When installing the inserts and adaptor, the DW wand must not be connected to the device.

- Take the desired insert or brush adaptor **54-B 149**.
- In the back of the insert (or adaptor) there are the two countersinks (A) where the DW wand coupling set screws will be tightened.
- Place the insert (or adaptor) on the DW wand coupling and tighten the two set screws with a 2.5 mm hex key (B) (included); make sure the set screws are properly aligned with the countersinks (A).

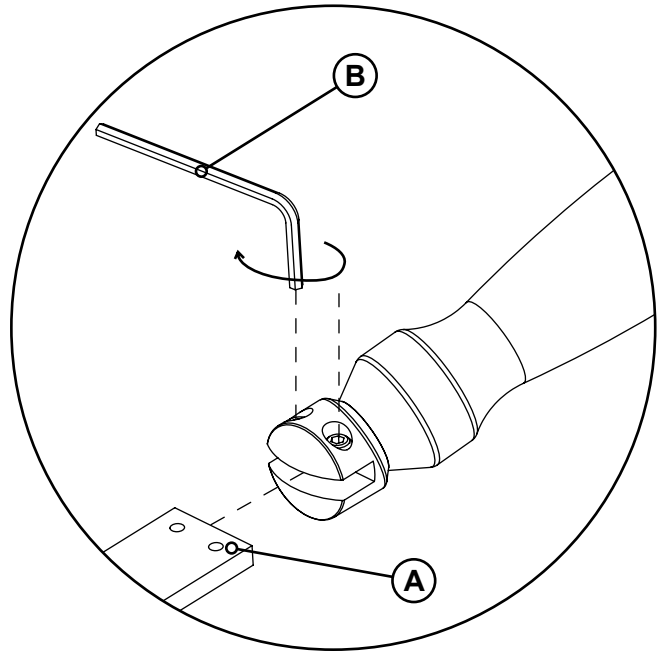

7.3. MOUNTING PAD ON GRAPHITE INSERT 100 mm



When installing the pads, the DW wand must not be connected to the device.

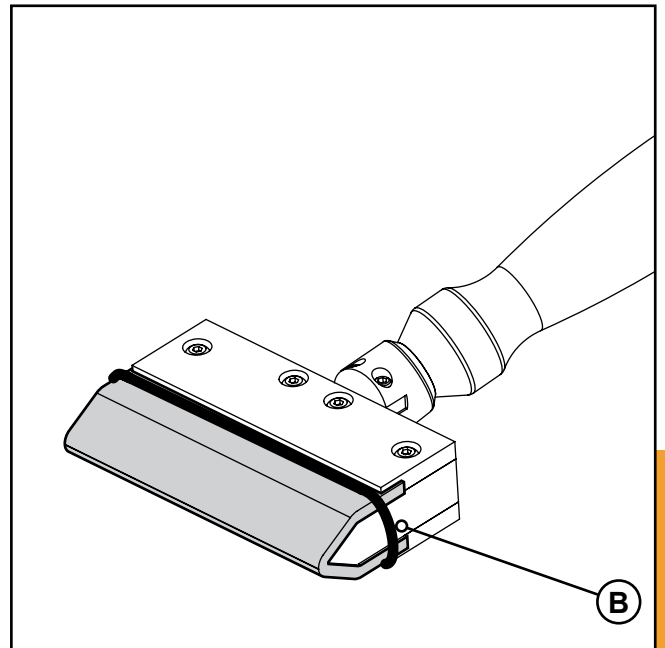
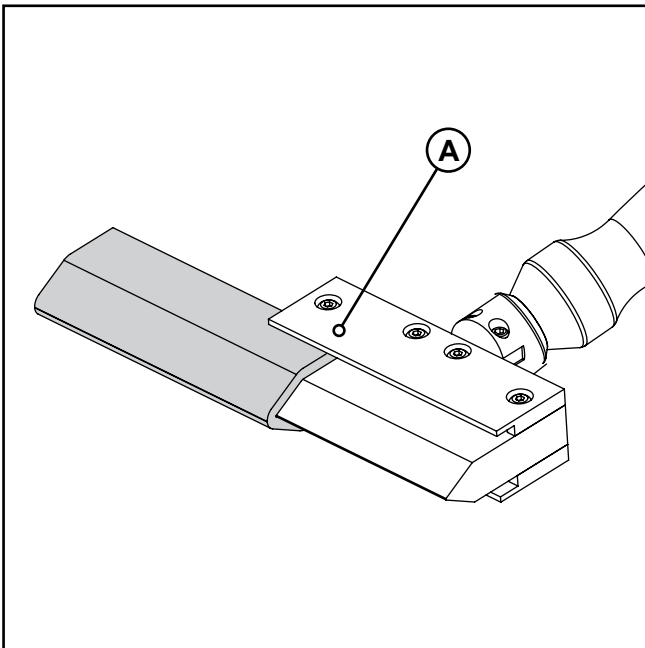

- Install the **54-B 607** insert on the DW wand (see *chapter 7.2*).
- Fold the **54-B 608** pad into a "U" shape and slide it into the fins with grooves (A) on the electrode.
- Fasten the pad in place using the **54-B 609** O-ring (B).

7.4. MOUNTING PAD ON GRAPHITE INSERT 45 mm



When installing the pads, the DW wand must not be connected to the device.

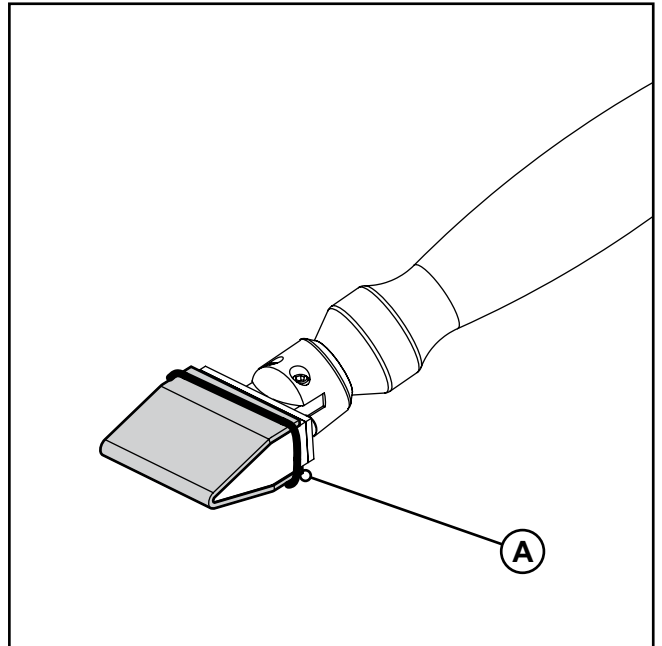
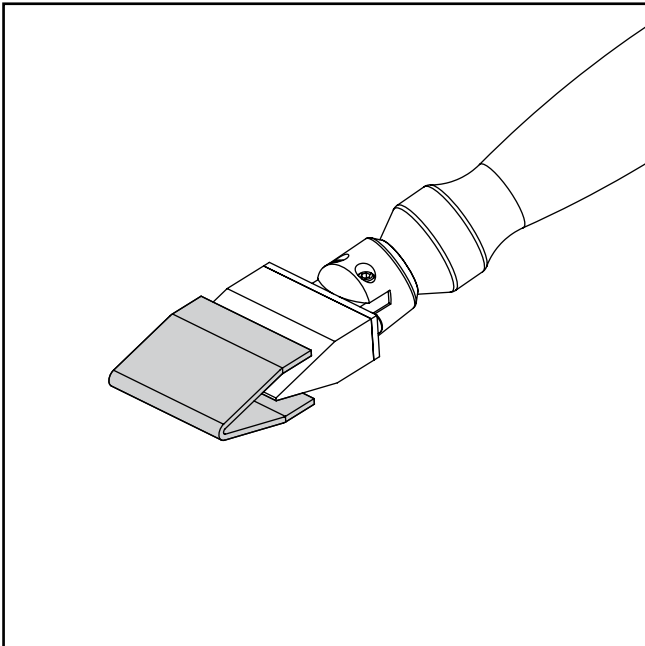

- Install the insert **54-B 009** on the DW wand (see *chapter 7.2*).
- Fold the **54-B 043** pad into a "U" shape and stick it on to the electrode.
- Fasten the **54-B 180** pad in place using the O-ring (A).

7.5. MOUNTING DW BRUSH



When installing the brushes, the DW wand must not be connected to the device.

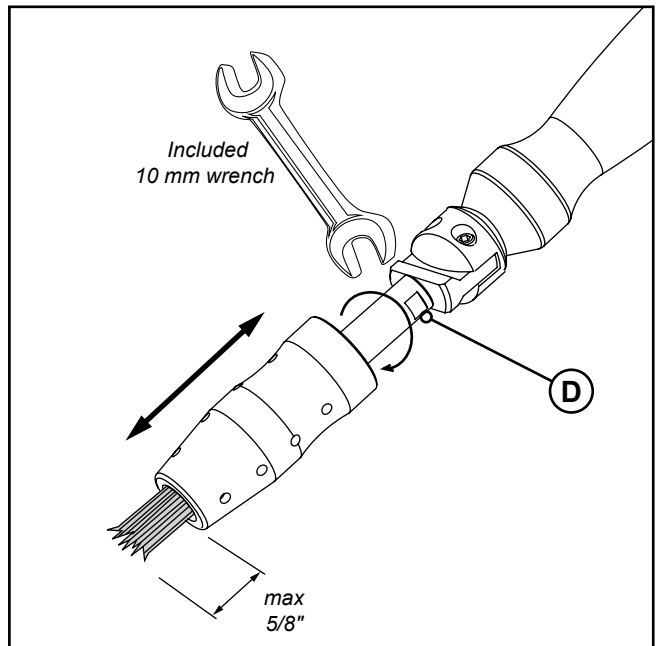
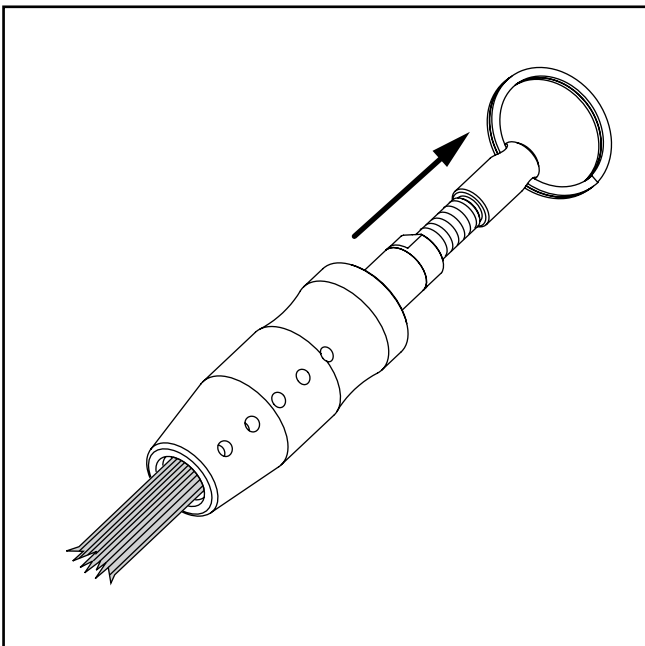
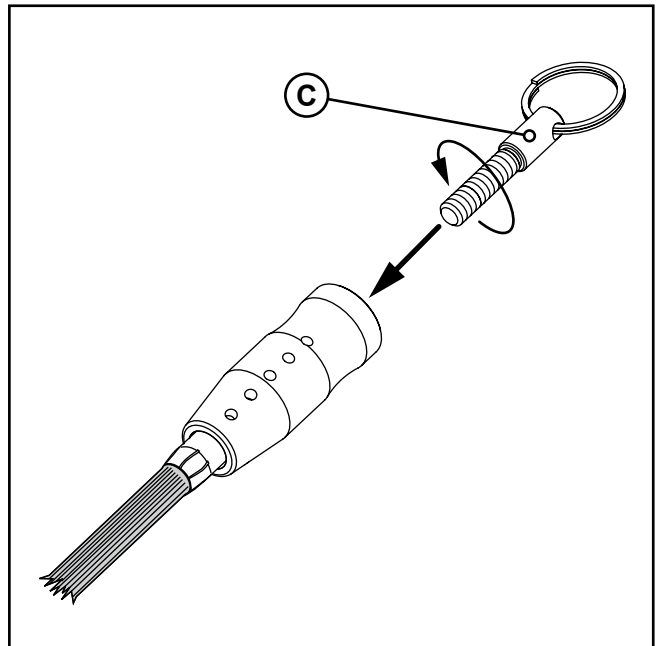
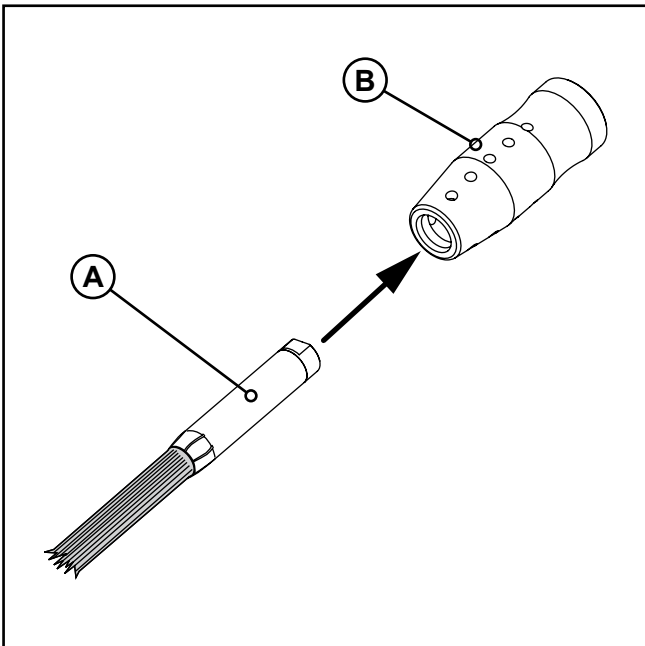

- Install the **54-B 149** brush adaptor (A) on the DW wand (see *chapter 7.2*).
- Insert the **54-B 604** DW brush (A) into the **54-B 605** sleeve (B).
- Screw the threaded coupling of the extraction tool **54-B 618** (C) onto the brush.
- Pull the brush out of the sleeve.
- Remove the extraction tool
- Use the 10 mm wrench (included) to tighten the brush firmly onto the adaptor thread. The brush coupling segment is shaped (D) for easy grip with the wrench.
- Ensure that no more than 5/8" (15 mm) of carbon fiber is exposed.

7.6. ELECTRICAL INSTALLATION

- Use the supplied cable to carry out the electrical installation of the DW wand; connect the female connector (A) to the DW wand (B) and insert the male connector (C) into the designated socket on the front panel of the device (D).

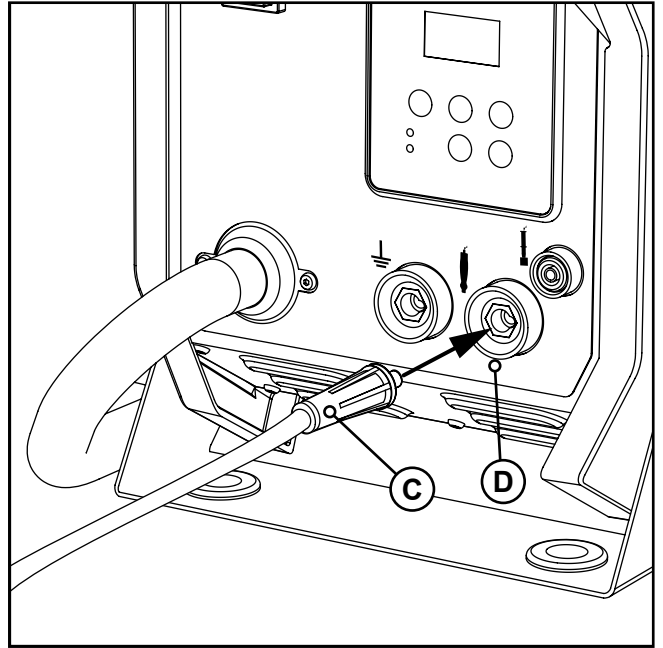
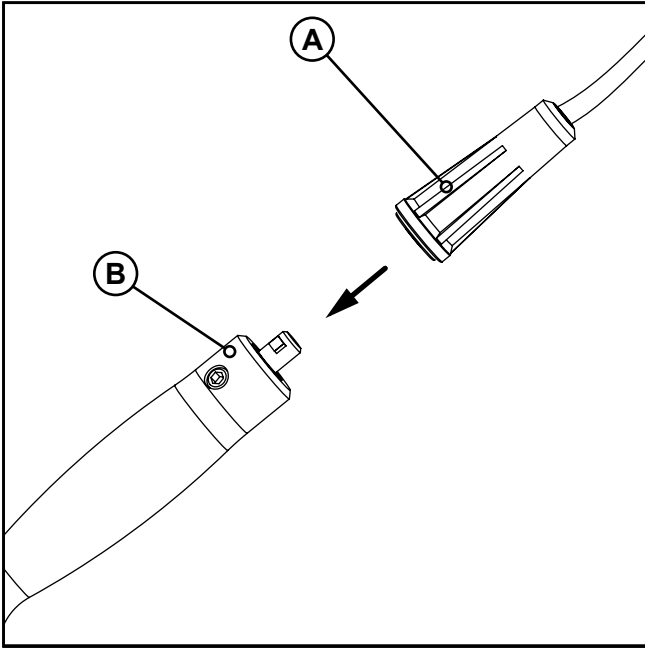

7.7. START OF PROCESSING

- Before starting to pickle / polish a piece of stainless steel, check that all the preliminary operations described in *chapter 5* have been carried out correctly.
- Make sure the most appropriate accessory is installed on the DW wand for the type of processing to be performed.
- Choose the most appropriate liquid for the type of processing to be carried out:
 - ◊ **SURFOX-T**, an heavy-duty cleaning solution suitable for both pickling and polishing.
 - ◊ **SURFOX-G**, a pH neutral cleaning solution suitable for pickling only

Always refer to the product data sheet for detailed indications regarding its field of use.
WALTER Customer Service (walter.com) is available for any additional information.



Acid solutions are dangerous and can cause damage to people and property: please read carefully the *chapter 1* on the safety regulations and personal protective equipment that must be used when working with these substances.

- Pour the electrolyte solution into a jar or plastic container large enough to hold the insert or brush.
- Fully immerse the insert with pad or brush in the container.



It is important to keep the electrodes always well wet to prevent them from overheating.

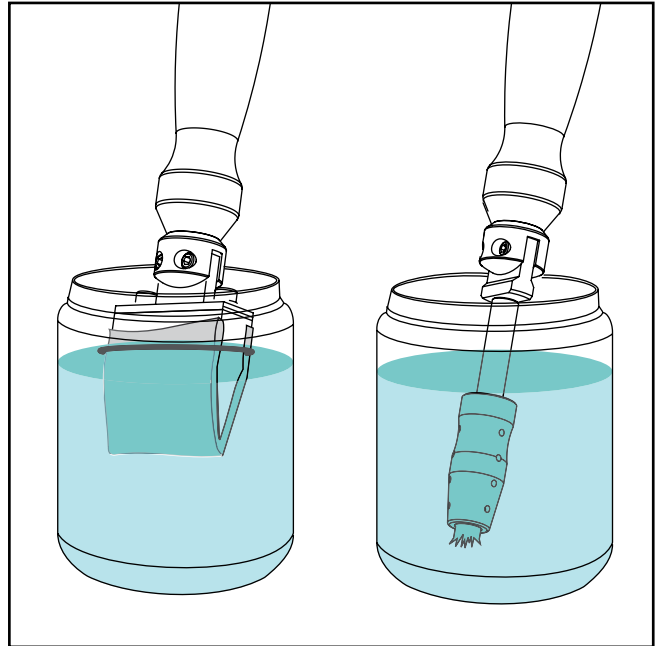

- Turn on the device by turning the main switch (located on the front panel of the unit) to the "I" position.
- Select the desired operating mode by pressing the **MODE** button on the control panel (see *chapter 3.3* for more information).
- Press the **SET** button to select the desired power level (see *chapter 3.4* for more information).
 In order not to cause excessive wear or damage to the accessories, it is recommended that you select the power level according to the following table, which takes into account both the power supplied by the SURFOX device model used, and the conductivity of the electrolyte solution.

ACCESSORY	PART No	SURFOX-T	SURFOX-G
Graphite insert 100 mm	54-B 607	MID	HIGH
Graphite insert 45 mm	54-B 009	LOW	MID
DW brush for S306	54-B 604	HIGH	HIGH

The table is to be considered valid only if the manufacturer's predefined voltage values are used in the various operating modes.

- Press the  button on the control panel to start the device.



When using the DW wand, the fume abatement system built into the device does not come into operation, therefore an adequate external extraction device must be operating.



Once started, the device switches off automatically after approximately 30 seconds of inactivity. This is a precautionary measure to prevent the wand from being accidentally powered at the end of processing.

UTILIZATION OF THE INDICATORS ON THE DISPLAY

During processing, bar indicators appear on the display showing in real time the voltage and current supplied by the device (see *chapter 3.1*). When the workpiece is not being touched, no current passes through the wand and the voltage is maintained at half the set voltage. The voltage only starts to rise gradually when work actually starts, thus minimizing the likelihood of arcing or sparking at the point of contact between the brush/insert and the weld to be cleaned/polished.

- Start cleaning/polishing by positioning the pad/brush on the stainless steel workpiece.
- Pass the pad/brush over the weld by applying light pressure and continue the process until each sign of oxidation is completely removed. Sparks and foam may form at the contact point between the brush/pad and the weld during processing. This is perfectly normal.
- If necessary, use the – and + buttons on the control panel to adjust the output voltage and to obtain better results (if you change operating mode, the voltage returns to the default level preset by the manufacturer).

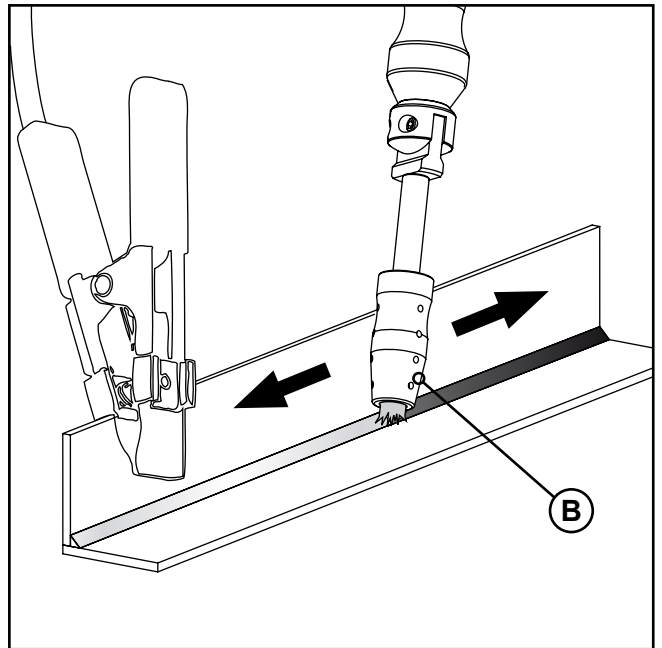
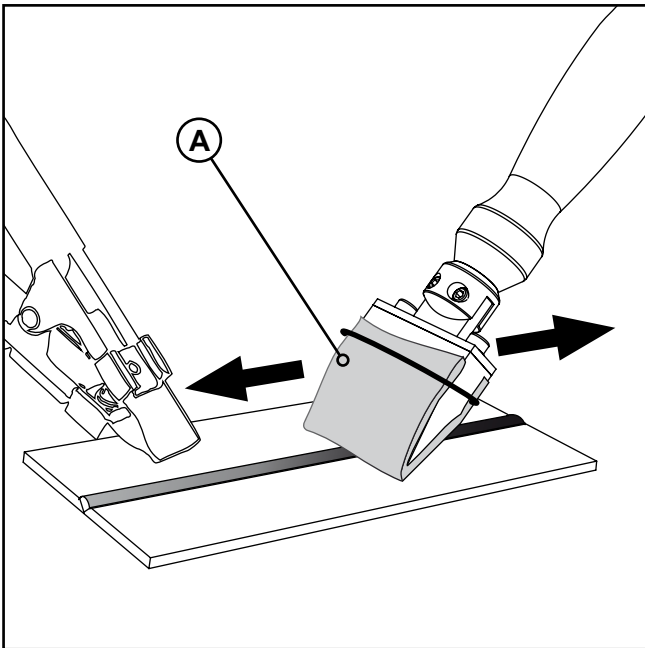

- The 100 mm or 45 mm pad (A) is particularly suitable for large welds, while the DW brush (B) is suitable for hard-to-reach welds.



- The polishing process requires a greater amount of electrolyte solution than pickling.
- Always keep the pad/brush well moistened with the electrolyte solution to avoid overheating and a consequent significant reduction in its working life; if there are obvious signs of wear, replace the component immediately.
- If the power and/or voltage is increased during processing, the electrolyte solution evaporates more quickly; make sure that the pad or brush is always wet.
- Never use an insert without its matching pad; the insert must never be placed in direct contact with the steel workpiece.
- When carrying out cleaning/polishing, keep the brush perpendicular to the weld and never press the carbon bristles excessively against the surface to be treated (C).
- For best results, periodically adjust the PTFE sleeve of the brush to leave approximately 5/8" (15 mm) of carbon fiber is exposed.

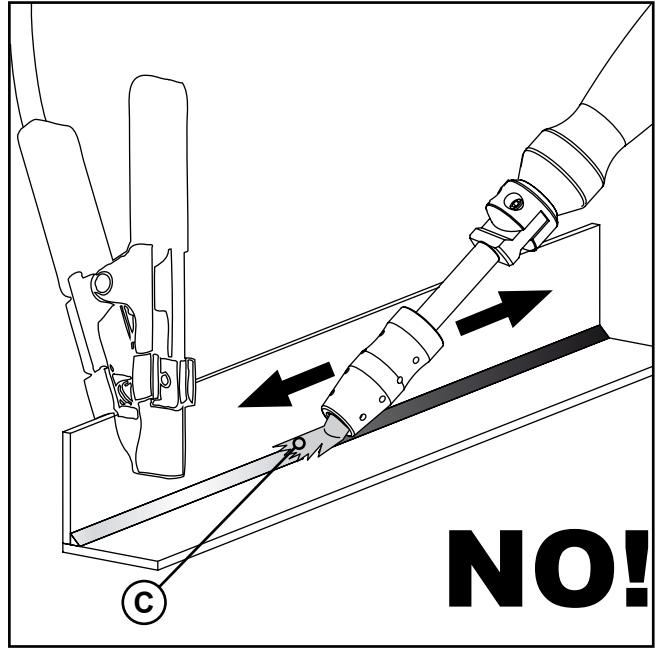

7.8. AFTER PROCESSING

- Press the  button on the control panel to stop the current supply to the DW wand.
- Put the DW wand back in its holder (A).



At the end of processing, always store the DW wand and other accessories appropriately. Never place the wand on top of the device during breaks or at the end of processing, as the electrolyte solution could drip from the dampened pad/brush and penetrate inside the unit. Always use the appropriate holder and empty the collection tray when necessary. The device should in any case be kept as clean as possible.

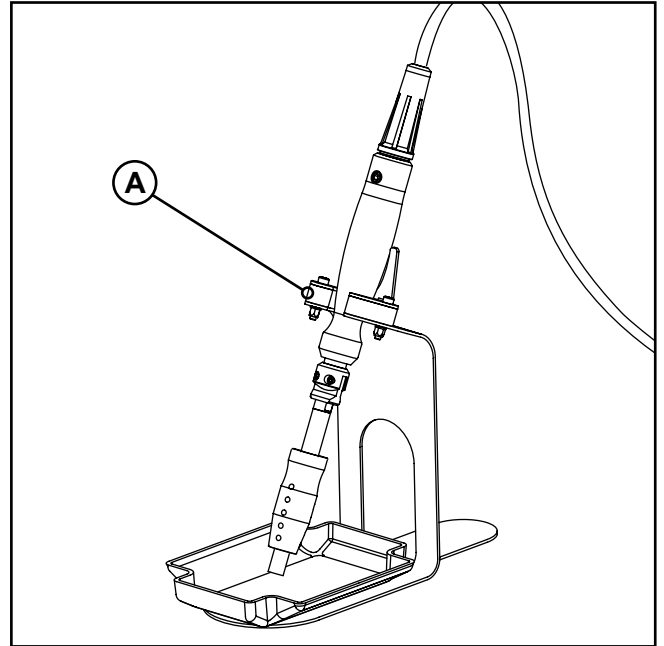

- Disconnect the ground cable crocodile clip from the machined part.
- Wipe out excess of electrolyte solution with a microfiber cloth **54-B 090**.
- Use the SURFOX-N solution on the treated piece.



It is very important to spray the SURFOX-N solution on the workpiece; this product neutralizes any residual electrolyte, thus avoiding the formation of halos and white spots (which can only be eliminated by repeating the entire process). Alternatively, it is possible to clean the surface with an abundant jet of water.

- Rub the surface with a microfiber cloth **57-M 001**.
- Dry the surface using a dry microfiber cloth.

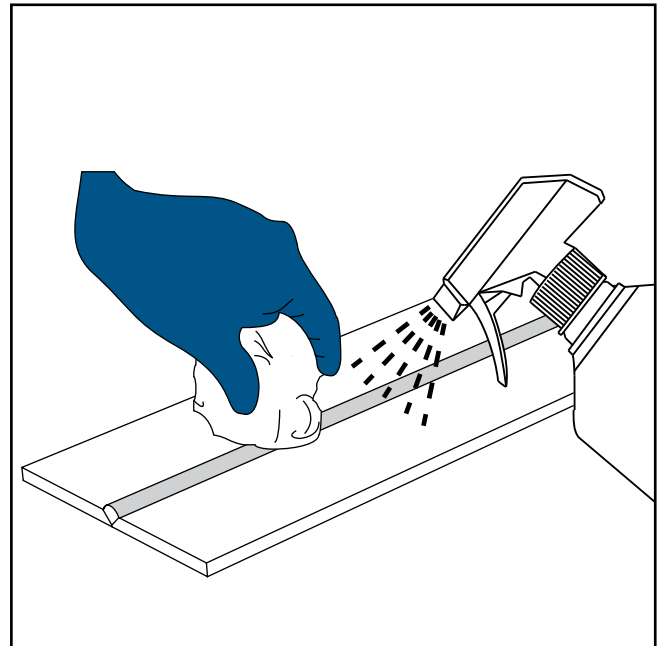

7.9. SHUTDOWN

- Turn off the device by turning the main switch to the "O" position.
- Disconnect the unit plug from the power supply socket.
- Carry out routine maintenance on the device as described in *chapter 9.1*.
- To limit any environmental impact, used pad and used liquids must always be disposed of in accordance with current waste disposal regulations (see *chapter 10* for additional information).

8. MARKING/ETCHING (OPTIONAL)

Thanks to the electrochemical marking/etching Standard Kit **54-B 080** and the screen printing stencils (both optional), the SURFOX 306 can be used to mark stainless steel; with this function you can instantly print any logo on stainless steel. Electrochemical marking/etching uses the principle of electrolysis by **neutral liquids which are neither irritating nor corrosive**.

The standard dimensions of a screen-printing stencils range from a minimum of 25x15 mm to a maximum of 257x170 mm. If used correctly, the screen can be used for about 500 markings without having to replace it. However, the duration of the stencils also depends on other important factors such as its size or the density of the background that makes up the graphics.

WALTER also gives you the option of buying the Pro Marking Kit **54-B 081** (compatible only for PC) for making disposable stencils that are particularly suitable for marking serial numbers, logos and CE plates



Only use original marking kits and screens. Uncertified products, such as unsuitable electrolyte solutions or marking inserts and pads not specifically designed for this function, could cause permanent damage to both the device and the workpiece. To purchase the marking kits, custom screen-printing screens or printer, please contact the **WALTER Graphics Division** (walter.com).

8.1. OVERVIEW OF MARKING/ETCHING WAND ACCESSORIES

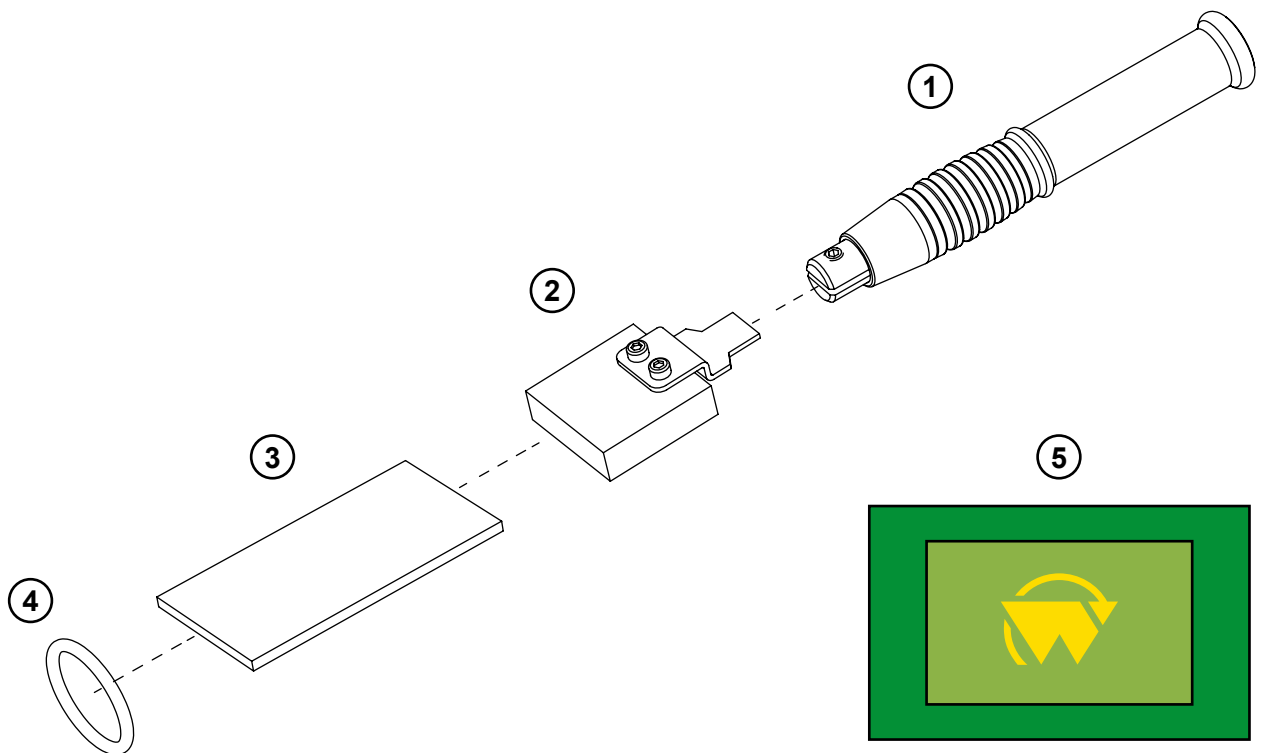

1	54-B 200	Marking/etching wand	optional	p. 41
2	54-B 088	Marking graphite insert 35 x 10 mm	optional	p. 42
3	54-B 083	Marking pad for graphite insert 35 x 10 mm	optional	p. 42
4	54-B 089	O-ring for graphite insert 35 x 10 mm	optional	p. 42
5	-	Screen-printing stencil	optional	p. 41

WALTER Customer Service (walter.com) is available for any additional information.

8.2. MARKING INSERT INSTALLATION



When installing the inserts, the marking/etching wand should not be connected to the device.

- Take the marking insert **54-B 088**.
- Insert the coupling tab (A) into the appropriate slot in the marking/etching wand.
- Tighten the set screw using a 2.5 mm hex wrench (B).

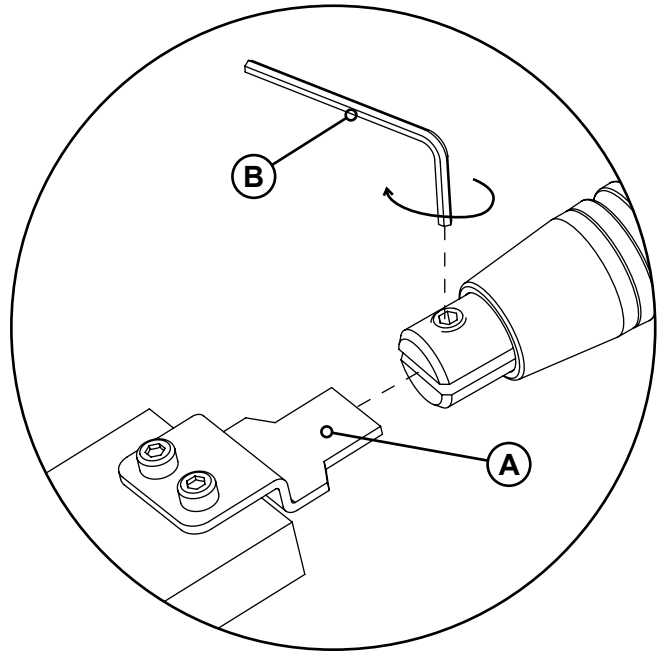

8.3. MOUNTING A PAD ON THE MARKING INSERT



When installing the pad, the marking/etching wand must not be connected to the device.

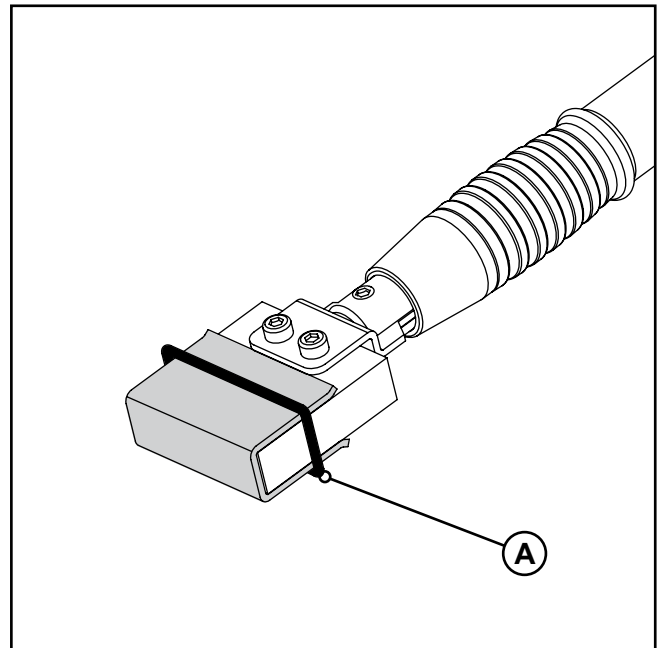
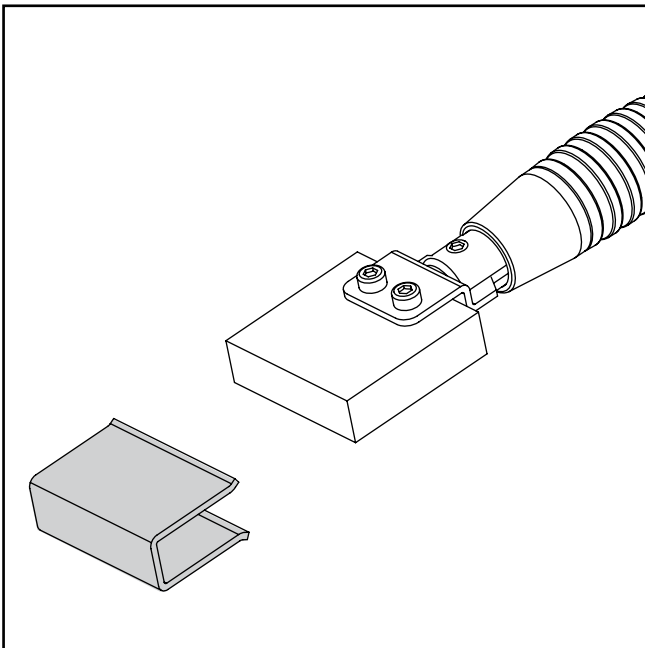

- Install the **54-B 088** insert on the marking/etching wand (see *chapter 8.2*).
- Fold the **54-B 083** pad into a "U" shape and stick it on to the electrode.
- Fasten the pad in place using the **54-B 089** O-ring (A).

8.4. ELECTRICAL INSTALLATION

- Use the connecting cable (A) to carry out the electrical installation of the marking/etching wand; connect one end to the appropriate coupling on the wand (B) and the other into the designated socket on the front panel of the device (C).

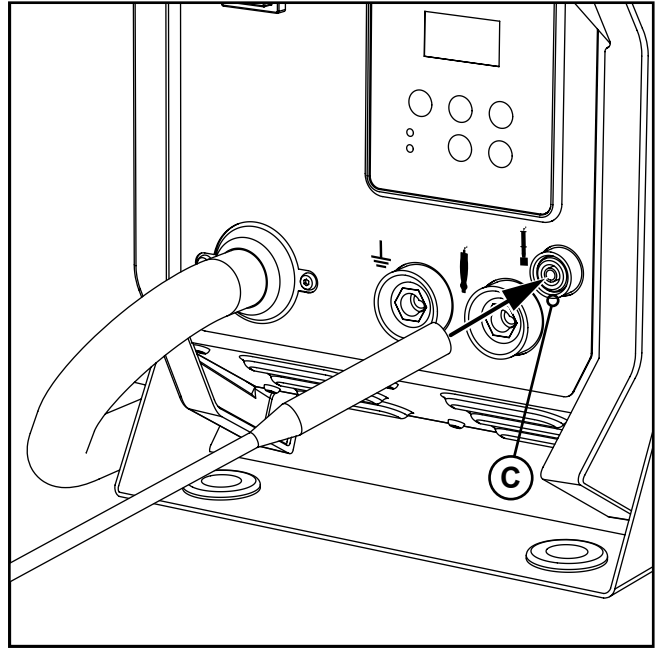
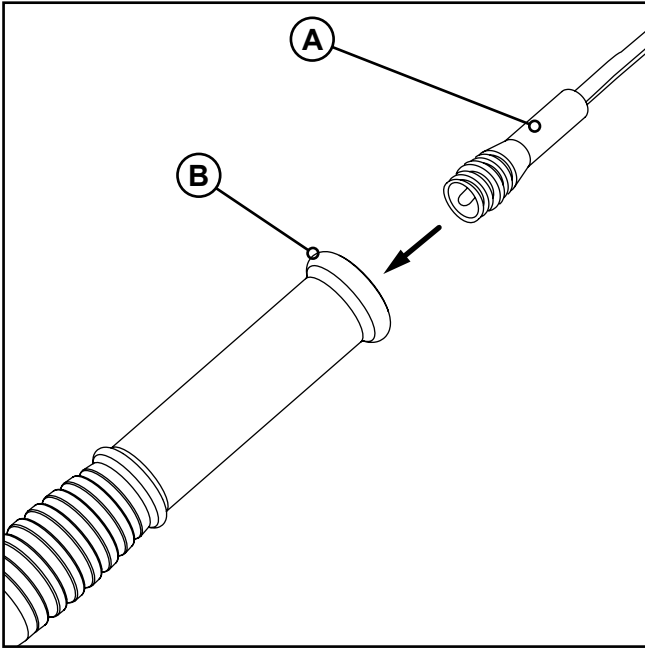

- Lay the screen-printing stencil (D) on the piece to be marked/etched and check that all the preliminary operations described in *chapter 5* have been carried out correctly. In particular, make sure that the ground cable crocodile clip has been fastened to the stainless steel piece to be treated.



Before using a new screen-printing stencil, it is recommended that you use it on a sample surface to make some test markings in order to fully open its meshes and obtain an optimal image.

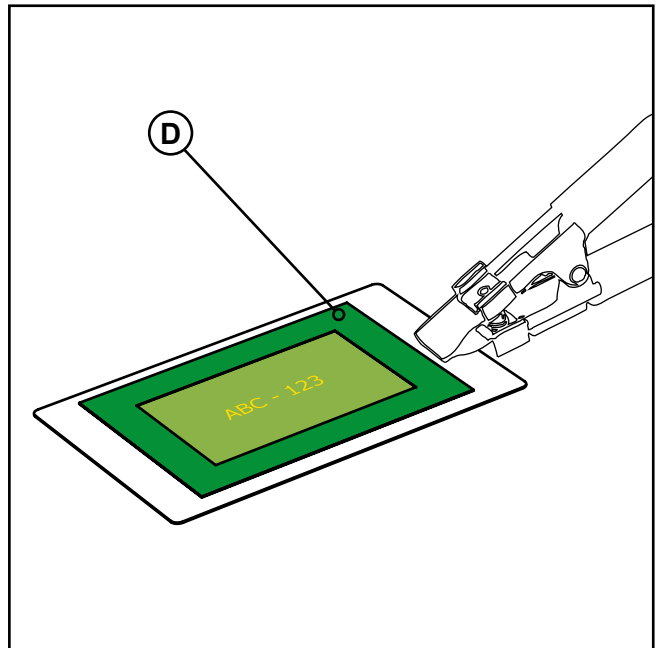

8.5. START OF PROCESSING

- Choose the most appropriate liquid according for the type of marking to be carried out:
 - ◊ **SURFOX-M**, for marking; the result will be a dark and high-contrast mark on the workpiece.
 - ◊ **SURFOX-E**, for etching; the result will be a clear, light marking on due to the a spark erosion principle.
- Pour a few drops of electrolyte solution (A) onto the marking pad.



The pad moistened with the electrolytic solution allows about 15 consecutive markings to be made, after which it must be remoistened.

- Turn on the device by turning the main switch (located on the front panel of the unit) to the "I" position.
- Select the desired operating mode by pressing the **MODE** button on the control panel (see *chapter 3.3* for more information).
- Unlike cleaning and polishing, the marking/etching process with the 35 mm insert requires a minimum amount of current, so it is not necessary to select a particular working power.
- Press the  button on the control panel to start the device.



Once started, the device switches off automatically after approximately 30 seconds of inactivity. This is a precautionary measure to prevent the wand from being accidentally powered at the end of processing.

- Repeatedly apply the wet marking pad to the logo or on the text that must be imprinted on the stainless steel surface (B).

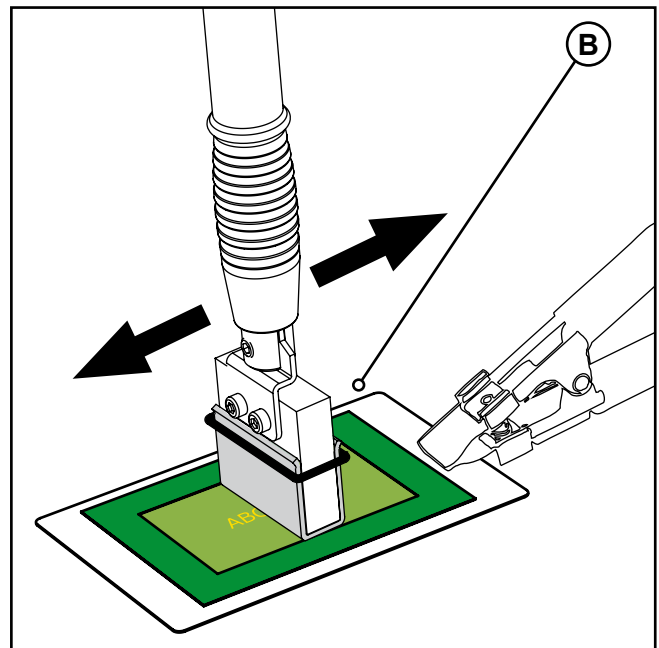
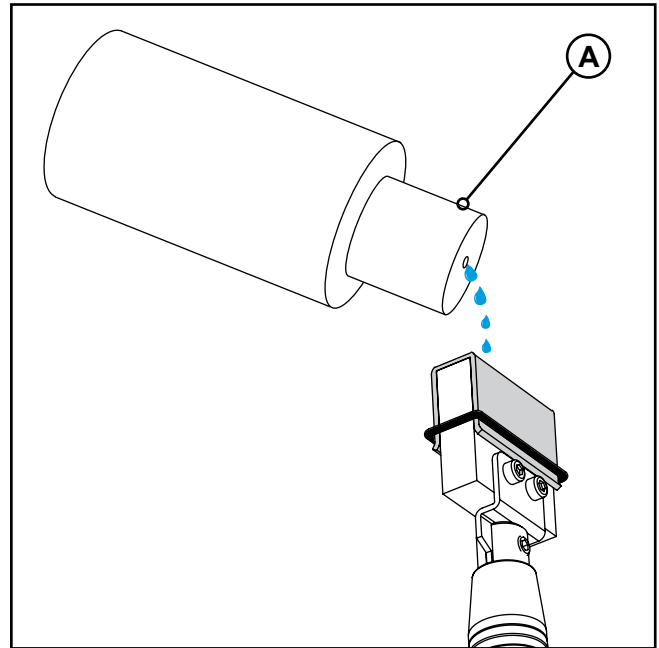

- Stay inside the edges of the stencil to avoid marking the steel outside the desired area.
- Always keep the pad well moistened with the electrolytic solution to avoid overheating and consequent significant reduction in its working life; if there are obvious signs of wear, replace the component immediately.
- Never use an insert without its matching pad; the insert must never be placed in direct contact with the stencil.
- The device automatically supplies the appropriate voltage when the marking operating mode is selected. Do not press the **-** and **+** buttons on the control panel to adjust the output power, otherwise a number of problems may occur, such as:
 - ◊ Weak and/or poorly defined markings.
 - ◊ Burns on the marking pad.
 - ◊ Burns on the screen-printing stencil.
 - ◊ Unwanted halos on the workpiece.

8.6. AFTER PROCESSING

- Press the  button on the control panel to stop the current supply to the marking/etching wand.
- Put the wand back in its holder (A).



At the end of processing, always store the wand and other accessories appropriately. If the wand should remain accidentally powered while resting on the treated piece, the electrochemical marking process would continue on each portion of stainless steel in contact with the pad and would permanently damage it.

Never place the wand on top of the device during breaks or at the end of processing, as the electrolyte solution could drip from the dampened pad and penetrate inside the unit. Always use the appropriate holder and empty the collection tray when necessary. The device should in any case be kept as clean as possible.

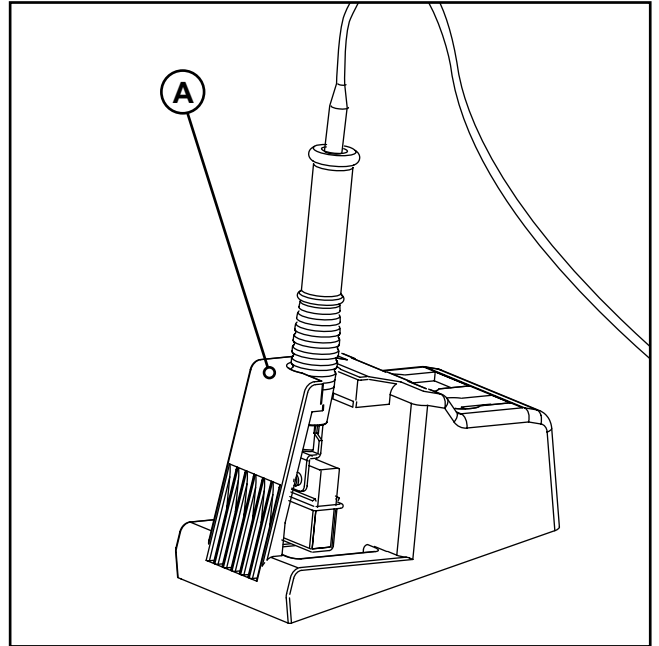

- Disconnect the ground cable crocodile clip from the machined part.
- Use the SURFOX-N solution on the treated piece.



It is very important to spray the SURFOX-N solution on the workpiece; this product neutralizes any residual marking solution, thus avoiding the formation of halos and white spots.

Alternatively, it is possible to clean the surface with an abundant jet of water.

- Rub the surface with a microfiber cloth dampened with clean water.
- Dry the surface using a dry microfiber cloth.

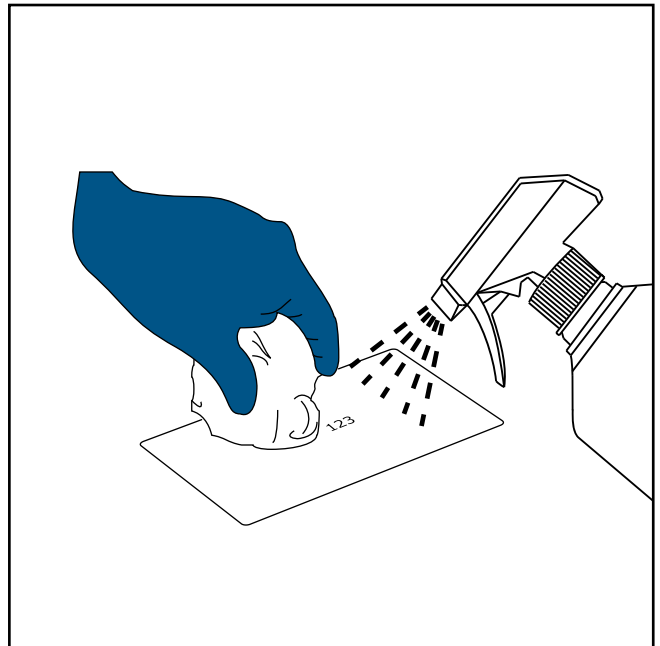

8.7. SHUTDOWN

- Turn off the device by turning the main switch to the "O" position.
- Disconnect the unit plug from the power supply socket.
- Carry out routine maintenance on the device as described in *chapter 9.1*.
- To limit any environmental impact, used pad and used liquids must always be disposed of in accordance with current waste disposal regulations (see *chapter 10* for additional information).

9. MAINTENANCE

Maintenance must be performed on the device only by qualified technicians authorized by the manufacturer.

WALTER is not liable for loss or damage caused to the device during repair operations carried out by personnel not specifically trained for this task.

The manufacturer also assumes no liability in the case of use of non-original parts or accessories during maintenance work; any direct or indirect loss or damage caused by such conduct is entirely the liability of the customer.



It is important to always proceed with extreme caution during maintenance operations, remembering to:

- Switch the main switch to the "O" position.
- Disconnect the device from the mains.
- Check the level of liquid in the tank and make sure it cannot leak while the device is being handled.
- If maintenance operations require the device to be opened, always take the utmost care in handling the internal parts, especially if it is suspected that there is a loss of electrolyte solution from the hydraulic circuit.
- Be careful when removing components inside the device as the plates and supports may have sharp edges.

It is recommended that you consult *chapter 1*, where all the safety regulations are detailed so that you can work on the device while also minimizing risks.

9.1. ROUTINE MAINTENANCE

BEFORE EACH WORK SHIFT

- Check all components of the device for wear and replace them if necessary; use only original spare parts.
- Ensure that the sockets, connectors and cables used are in good condition; the reliability of all electrical equipment must always be guaranteed.
- Keep the ventilation slots on the unit clean to ensure that these openings are not obstructed by any obstacles. Keep enough space around the device to ensure proper ventilation.

CLEANING PROCEDURES AT THE END OF THE WORK SHIFT

It's important to keep the device as clean as possible.

- Remove the pads/brushes from the insert/adaptor to prevent the formation of incrustations on the electrode due to the evaporation of the electrolyte solution.
- Neutralize all these tools with the SURFOX-N solution.
- After neutralizing, always rinse the pads/brushes with clean water and dry them with a dry microfiber cloth.
- If the pads/brushes show obvious signs of wear or burns, replace them immediately.
- Once cooled, clean the wand insert and tip with running water to prevent the formation of incrustations.
- Clean dust and dirt deposits on the outside of the unit.
- Keep air vents clean and free of any obstructions.
- Clean the power cord to prevent deterioration and check for possible damage to the cord and plug.

9.2. EXTRAORDINARY MAINTENANCE

Extraordinary maintenance operations are usually carried out by specialized technicians of the **WALTER** company or by its network of authorized service centers.

10. DISPOSAL AND SCRAPPING



Act to ensure maximum environmental protection.
Dispose of residual waste in compliance with Federal, Provincial, State and local environmental regulations.

10.1. PACKAGING

This type of waste is similar to urban waste and can be disposed of in municipal waste centers without posing an increased threat to humans and the environment.

10.2. USED PADS

They are special waste and must be disposed of in accordance with applicable laws.

10.3. WASTE LIQUIDS

During the processing (cleaning and polishing) heavy metals are deposited in the electrolytic solutions used: therefore used liquids are to be considered special waste and must be disposed of according to the laws in force in the country of use. Refer to **WALTER** Safety Data Sheet of the SURFOX electrolyte cleaning solutions.

10.4. OBSOLETE DEVICES AND EQUIPMENT

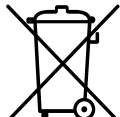

They are to be considered special waste, to be scrapped according to type. With reference to Directive EC-2002/96 on waste electrical and electronic equipment (WEEE), the user, when disposing of material, must separate the electrical and electronic components and dispose of them in appropriate authorized collection centers, or return them to the seller with the product still installed.

11. DECLARATION OF CONFORMITY

Exova
121 Boulevard Hymus
Pointe-Claire
Québec
Canada
H9R 1E6

T: +1 (514) 697-3273
F: +1 (514) 697-2090
C: ventes@exova.com
W: www.exova.com



TEST CERTIFICATE

J. WALTER COMPANY LTD. 5977 TRANS CANADA HIGHWAY POINTE-CLAIRE, Québec H9R 1C1 Requested by Nathalie Vézina X2848	Sample #: 48840 Lab #: 22156 COA #: 23756 Issue #: 2 Date: 2013-02-15	Material: NA Shape: NA Condition: Not Applicable
--	--	---

PO 230113NV **Customer's ID:** 2 samples 3" X 3" pre-passivated and identified as SURFOX-G sample 1 & 2 **Material:** Stainless steel panels

Description: Samples received were cleaned and passivated per ASTM A-380

Label: SURFOX-G sample 1		SALT SPRAY	
Parameter	Unit	Result	
# of Samples		2	
Specimen type		Panels	
Dimensions	inch.	3X3	
Exposure zone temperature	°F	92-97	
Exposure period	hrs	2.5	
Angle		15-30°	
pH		6.5-7.2	
Solution Concentration	% NaCl	4-6	
Collection Rate	ml/hr/80cm²	1.0-2.0	
Type of water	ASTM	Type IV	
Purity of salt		99.95%	
Copper content	ppm	< 0.3	
Total other impurities		< 0.3%	
Halides content		< 0.1%	
Observation		See comments	

Tested in Accordance To ASTM B117-11

SALT SPRAY test in accordance with ASTM A967-05 practice C.

After 2.5 hour exposition in the salt spray chamber:

Surfox- G sample 1: No rust present

Surfox- G sample 2: No rust present

Issue 2: To correct sample identification from issue 1, dated 2013-02-08

Exova
121 Boulevard Hymus
Pointe-Claire
Québec
Canada
H9R 1E6

T: +1 (514) 697-3273
F: +1 (514) 697-2090
C: ventes@exova.com
W: www.exova.com



TEST CERTIFICATE

J. WALTER COMPANY LTD. 5977 TRANS CANADA HIGHWAY POINTE-CLAIRE, Québec H9R 1C1 Requested by Nathalie Vézina X2848		Sample #: 48840 Lab #: 22156 COA #: 23756 Issue #: 2 Date: 2013-02-15	Material: NA Shape: NA Condition: Not Applicable
PO	230113NV	Customer's ID: 2 samples 3" X 3" pre-passivated and identified as SURFOX-G sample 1 & 2	Material: Stainless steel panels
Description:	Samples received were cleaned and passivated per ASTM A-380		

Label: SURFOX-G sample 1

TECHNICAL SERVICES **

WATER IMMERSION TEST as per ASTM A967-05 practice A

The samples were immersed in distilled water for 1h, followed by a drying period of 1 h in a dessicator. This cycle was repeated 12 times. Test results

Surfox-G sample 1: No metallic iron particles were observed on the test zone at the end of the cycles.

Surfox-G sample 2: No metallic iron particles were observed on the test zone at the end of the cycles.

HUMIDITY TEST as per ASTM A967-05 Practice B.

The samples were cleaned with acetone and dried in a dessicator. They were then exposed to 100% humidity (38±3 °C) for 24 hours. Test results :

Surfox-G sample 1: No rust observed on the tested zone at the end of exposure.

Surfox-G sample 2: No rust observed on the tested zone at the end of exposure.

COPPER SULFATE TEST in accordance with ASTM A967-05 practice D.

The test solution was prepared by dissolving 4 grams of copper sulfate in 250 ml of water, to which 1 ml of sulfuric acid was added.

The test solution was swabbed on the samples and were to keep them humid for at least 6 minutes. Test results:

Surfox-G sample 1: No copper deposit observed on the tested zone.

Surfox-G sample 2: No copper deposit observed on the tested zone.

POTASSIUM FERRICYANIDE-NITRIC ACID TEST in accordance with ASTM A967-05 practice E.

The test solution was prepared by adding 10g of chemically pure potassium ferricyanide to 500ml of distilled water , adding 30 mL of 70% nitric acid, agitating until all of ferricyanide was dissolved, and diluting to 1000 mL with distilled water. The test solution was swabbed on the surface of the samples. Test results :

Surfox-G sample 1: There was no formation of a dark blue color within 30s on the tested zone.

Surfox-G sample 2: There was no formation of a dark blue color within 30s on the tested zone.

Each test was performed on separate samples.

Issue 2: To correct sample identification from issue 1, dated 2013-02-08

Aerospace/military samples shall be retained for 6 months, other samples, see contract terms and conditions.

The recording of false, fictitious or fraudulent statements or entries on this document may be punished as a felony under federal law.

* Denotes the laboratory is accredited to the identified test method by ISO 17025 but not by NadCap.

** Denotes the laboratory is not accredited to the identified test method by ISO 17025 or NadCap.

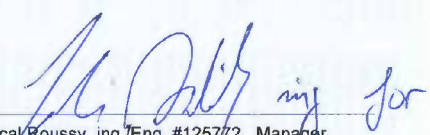
Pascal Roussy, ing./Eng. #125772, Manager,
Metallurgy and Mechanical Testing

Exova
121 Boulevard Hymus
Pointe-Claire
Québec
Canada
H9R 1E6

T: +1 (514) 597-3273
F: +1 (514) 597-2090
C: ventes@exova.com
W: www.exova.com



TEST CERTIFICATE

J. WALTER COMPANY LTD. 5977 TRANS CANADA HIGHWAY POINTE-CLAIRE, Québec H9R 1C1 Requested by Nathalie Vézina X2848	Sample #: 31067 Lab #: 13887 COA #: 15164 Issue #: 1 Date: 2010-11-19	Material: NA Shape: NA Condition: Not Applicable
--	--	---

PO	08112010-NV	Client's ID	8 test panels 3" X 10" - 4 panels identified as Surfox-H and 4 panels identified as Surfox-T	Description	Samples received were cleaned and passivated per ASTM A380
-----------	-------------	--------------------	--	--------------------	--

Label: Surfox-H and T	TECHNICAL SERVICES **
------------------------------	------------------------------

WATER IMMERSION TEST as per ASTM A967-05 practice A
The two samples were immersed in distilled water for 1h, followed by a drying period of 1 h in a dessicator
This cycle was repeated 12 times
Observation after the test :
Surfox-H : No metallic iron particles were observed in the test zone at the end of the cycles.
Surfox-T : No metallic iron particles were observed in the test zone at the end of the cycles.

Aerospace/military samples shall be retained for 6 months, other samples, see contract terms and conditions.
The recording of false, fictitious or fraudulent statements or entries on this document may be punished as a felony under federal law.
* Denotes the laboratory is accredited to the identified test method by ISO 17025 but not by NacCap.
** Denotes the laboratory is not accredited to the identified test method by ISO 17025 or NacCap.

Fadi Saliby, ing.

Exova
 121 Boulevard Hymus
 Pointe-Claire
 Québec
 Canada
 H9R 1E6

T: +1 (514) 697-3272
 F: +1 (514) 697-2090
 C: ventas@exova.com
 W: www.exova.com



TEST CERTIFICATE

J. WALTER COMPANY LTD. 5977 TRANS CANADA HIGHWAY POINTE-CLAIRE, Québec H9R 1C1 Requested by Nathalie Vézina X2848	Sample #: 31068 Lab #: 13887 COA #: 15165 Issue #: 1 Date: 2010-11-19	Material: NA Shape: NA Condition: Not Applicable
---	---	--

PO	08112010-NV	Client's ID	Description	Samples received were
			8 test panels 3" X 10" - 4 panels identified as Surfox-H and 4 panels identified as Surfox-T	cleaned and passivated per ASTM A380

Label: Surfox-H and T	TECHNICAL SERVICES **
-----------------------	-----------------------

HUMIDITY TEST as per ASTM A967-05 Practice B.

The two samples were cleaned with acetone and dried in a dessicator. They were then exposed to 100% humidity (38±3 °C) for 24 hours.

Test results :

Surfox-H : No rust observed

Surfox-T : No rust observed

Aerospace/military samples shall be retained for 6 months, other samples, see contract terms and conditions.
 The recording of false, fictitious or fraudulent statements or entries on this document may be punished as a felony under Federal law.
 * Denotes the laboratory is accredited in the identified test method by ISO 17025 but not by NadCap.
 ** Denotes the laboratory is not accredited to the identified test method by ISO 17025 or NadCap.

Fadi Saliby, ing.
 Fadi Saliby, ing.

Exova
121 Boulevard Fymus
Pointe-Claire
Québec
Canada
H9R 1E6

T: +1 (514) 697-3273
F: +1 (514) 697-2090
C: venina@exova.com
W: www.exova.com



TEST CERTIFICATE

J. WALTER COMPANY LTD. 5977 TRANS CANADA HIGHWAY POINTE-CLAIRE, Québec H9R 1C1 Requested by Nathalie Vézina X2848	Sample #: 31069 Lab #: 13887 COA #: 15166 Issue #: 1 Date: 2010-11-19	Material: NA Shape: NA Condition: Not Applicable
--	--	---

PO	08112010-NV	Client's ID	8 test panels 3" X 10" - 4 panels identified as Surfox-H and 4 panels identified as Surfox-T	Description	Samples received were cleaned and passivated per ASTM A380
-----------	-------------	--------------------	--	--------------------	--

Label: Surfox-H and T		SALT SPRAY	
Parameter	Unit	Result	
# of Samples		2	
Specimen type		Panels	
Dimensions	inch.	3X10	
Exposure zone temperature	°F	92-97	
Exposure period	hrs	3	
Angle		15-30°	
pH		6.5-7.2	
Specific gravity		1.0255-1.040	
Collection Rate	ml/hr/80cm²	1.0-2.0	
Type of water	ASTM	Type IV	
Purity of salt		99.95%	
Copper content	ppm	< 0.3	
Total other impurities		< 0.3%	
Halides content		< 0.1%	
Observation		See comments	

Tested in Accordance To SOP-54-009-93 (ASTM B117-09)

SALT SPRAY test in accordance with ASTM A967-05 practice C.

After 2 hour exposition in the salt spray chamber:

Surfox-H: No rust present

Surfox-T: No rust present

Aerospace/military samples shall be retained for 6 months, other samples, see contract terms and conditions.
The recording of false, fictitious or fraudulent statements or entries on this document may be punished as a felony under federal law.
* Denotes the laboratory is accredited to the identified test method by ISO 17025 but not by NadCap.
** Denotes the laboratory is not accredited to the identified test method by ISO 17025 or NadCap.

Fadi Saibby, ing.

1 of 1

THE RESULTS PRESENTED ABOVE RELATE ONLY TO THE ITEMS SUBMITTED FOR TESTING
THIS CERTIFICATE OR REPORT SHALL NOT BE REPRODUCED EXCEPT IN FULL, WITHOUT APPROVAL OF LABORATORY.

Accredited
NadcapTM
Materials Testing Laboratory
Pointe-Claire Laboratory

Exova
 121 Boulevard Hymus
 Pointe-Claire
 Québec
 Canada
 H9R 1E6

T: +1 (514) 697-3273
 F: +1 (514) 697-2090
 C: ventes@exova.com
 W: www.exova.com



TEST CERTIFICATE

J. WALTER COMPANY LTD. 5977 TRANS CANADA HIGHWAY POINTE-CLAIRE, Québec H9R 1C1 Requested by Nathalie Vézina X2848	Sample #: 31070 Lab #: 13887 COA #: 15167 Issue #: 1 Date: 2010-11-19	Material: NA Shape: NA Condition: Not Applicable
--	--	---

PO	06112010-NV	Client's ID	Description	Samples received were
			8 test panels 3" X 10" - 4 panels identified as Surfox-H and 4 panels identified as Surfox-T	cleaned and passivated per ASTM A380

Label: Surfox-H and T	TECHNICAL SERVICES **
------------------------------	------------------------------

COPPER SULFATE test in accordance with ASTM A967-05 practice D.

The test solution was prepared by dissolving 4 grams of copper sulfate in 250 ml of water, to which 1 ml of sulfuric acid was added. The test solution was swabbed on the two samples and were to keep them humid for at least 6 minutes.

Test results:

Surfox-H :No copper deposit observed
 Surfox-T :No copper deposit observed

Aerospace/military samples shall be retained for 6 months, other samples, see contract terms and conditions.
 The recording of false, fictitious or fraudulent statements or entries on this document may be punished as a felony under federal law.
 * Denotes the laboratory is accredited to the identified test method by ISO 17025 but not by NadCap.
 ** Denotes the laboratory is not accredited to the identified test method by ISO 17025 or NadCap.

Fadi Saliba
 Fadi Saliba, Ing.

12. GENERAL WARRANTY CONDITIONS

- The SURFOX 306 and its accessories are inspected and tested before shipment and are warranted to be free from any defect in material and faulty workmanship
- Devices built by **WALTER** are guaranteed against defects in material and construction for a period of 24 months after the date of original purchase.
- If an examination shows that the malfunction was caused by defective material or faulty workmanship, **WALTER** will repair (or at our option, replace the unit) without charge.
- In the event of improper use, **WALTER** will not be liable for any of the following:
 - ◇ Personal injury (minor, moderate, or fatal) to the user or a third party.
 - ◇ Damage to property in the vicinity of the device or damage to the device itself.
 - ◇ Device performance below expectations.
 - ◇ Use in violation of applicable regulations.
 - ◇ Incorrect installation of the device.
 - ◇ Use of a power supply that does not comply with the equipment specifications.
 - ◇ Serious lack of maintenance.
 - ◇ Unauthorized modifications or adjustments.
 - ◇ Use of non-original spare parts or spare parts not specific to this model range.
 - ◇ Use of liquids that are not recommended by **WALTER** or not specific to this model range.
 - ◇ Failure, in whole or in part, to follow the instructions.
 - ◇ Exceptional conditions.
 - ◇ Other improper uses.
- Work covered by the warranty will be carried out at the **WALTER** Factory or Authorized Service Center on the following terms:
 - ◇ The warranty does not apply when normal maintenance is required.
 - ◇ Freight, packaging and shipping costs are always for the user's account and goods travel at the user's risk; we must receive the material freight prepaid and suitably packed.
 - ◇ The warranty does not apply to products which have been dismantled, repaired or in any way tampered with by unauthorized staff, or if the serial number has been removed or modified.
 - ◇ Failures deriving from knocks, negligence, improper use, incorrect power supply or correction errors are not covered by the warranty.
 - ◇ The warranty does not cover any damage caused by accidents, modifications, use of improper accessories, abuse or misuse, which also includes overloading the tool beyond its rated capacity as well as its continued use after partial failure.
 - ◇ The device's expandable accessory components are not covered by the warranty.
 - ◇ The warranty covers the materials and labor necessary for the replacement operations. Freight, traveling expenses etc. are not included and will be billed at cost.
- No other warranty, written or verbal, is authorized.
- In no event shall **WALTER** be liable for any indirect, incidental or consequential damages from the sale of the product. This disclaimer applies both during and after the term of this warranty.
- This warranty gives you specific rights. The provisions contained in this warranty are not intended to limit, modify, take away from, disclaim or exclude any warranties set forth in any Provincial or State legislation. To the extent required by law, the provisions in any Provincial, State or Federal legislation with respect to warranties take precedence over the provisions in this warranty.

13. REPAIR AND SERVICE

- After the warranty period, our after-sales service will be at the customer's disposal for any adjustments and/or repairs to the devices we have produced. The relative costs will be submitted for approval in the form of a quotation (if requested) or billed on a time and materials basis.
- If it is necessary to return the SURFOX 306 to the **WALTER** Factory or Authorized Service Center, all the equipment should be carefully prepared and packed to ensure safe shipment:
 - ◇ Drain the electrolyte solution from the reservoir.
 - ◇ Clean the unit.
 - ◇ Use original shipping case.
 - ◇ Use sufficient packing.
 - ◇ Ship on a small pallet.
 - ◇ Be sure to include a shipping document with a detailed description of the problem, company name, address, phone and fax numbers, and contact person.



Collect all liquid in a suitable acid-resistant container.

WALTER is not liable for any loss or damage to persons or property due to the leakage of electrolyte solution from the reservoir during packing operations and shipping to service centers.

14. TECHNICAL SPECIFICATIONS

Model	SURFOX 306	
Part number	54-D 316	54-D 336
Input voltage	120 V - 50/60 Hz	230 V - 50/60 Hz
Input power	1200 W	2400 W
Input current	10 A	
Output voltage	3÷30 V	
Output voltage adjustment	1 V	
Output current adjustment	LOW, MID, HIGH	
Reservoir capacity	1.8 l	
Dispensing speed	1÷3.6 l/h	
Pump adjustments	Dynamic Manual Auto (8 levels)	
Input air pressure	min: 80 PSI max: 150 PSI	
Insulation class	IP21S	
Noise level	<70 dB (A)	
Weight (empty)	47 lb (21.5 kg)	
Dimensions	15.5" x 14.5" x 21" (390 x 365 x 535 mm)	
Wands	Blowing wand DW wand * Marking wand *	
Functions	Cleaning Polishing Marking	

* optional