



Manufacturer: Thermadyne Industries
Address: 82 Benning Street West Lebanon,
New Hampshire 03784 USA
Telephone: 1-800-426-1888 • Fax: 1-800-535-0557
Email: sales@thermalarc.com
www.thermalarc.com

Roll Cage Kit for Fabricator 211i
Part Number: W4015104

Roll Cage Kit for Fabricator 252i
Part Number: W4015101

Assembly Instructions

General Information

This document provides a guide for the assembly and installation of the Roll Cage Kit onto the Fabricator 211i/252i power source. The Roll Cage protects the Fabricator power source case from collision damage plus doubles as a sturdy hand lifting frame.

NOTE

The Roll Cage Kit is designed to fit the Fabricator 211i/252i power source without any modifications.

NOTE

Only the Roll Cage Kit or Welding Equipment Cart may be fitted to the Fabricator 211i/252i power source at any one time.



WARNING

Do Not lift the Roll Cage / power supply via a crane or similar means. The Roll Cage / power supply should only be lifted by hand.

For an Equipment Cart specifically designed for use with the Fabricator 211i or Fabricator 252i plus gas cylinder, welding gun and various accessories, use Part No. W4015001.

Recommended Tools

12mm or 4mm Open Ended Wrench or 6" Adjustable Wrench

6mm Allen Wrench (Hex Key)

T25 Torx-Bit for power source case screw



Assembly Instructions



WARNING





Unplug the Fabricator power source unit before attaching the Roll Cage Kit.

NOTE

Use the following assembly procedure to attach the Roll Cage to the Power Source. It is difficult to attach the Power Source to a fully assembled Roll Cage.

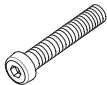
FABRICATOR 211i & 252i ROLL CAGE ASSEMBLY INSTRUCTIONS

Supplied Parts

Item	Description	Qty	
1	Rear Frame	1	
2	Base Assembly	1	
3	Front Frame	1	
4	Top Support Plate	1	
5	Handle	1	
6	M8 x 40mm Socket Cap Screw Torque force: 19 - 22 ft lb (26 - 30 N.m)	2	
7	M8 x 20mm Socket Cap Screw Torque force: 19 - 22 ft lb (26 - 30 N.m)	4	
8	Saddle Washer (M8)	6	
9	Nut (M6) Torque force: 14 - 17 ft lb (19 - 23 N.m)	3	

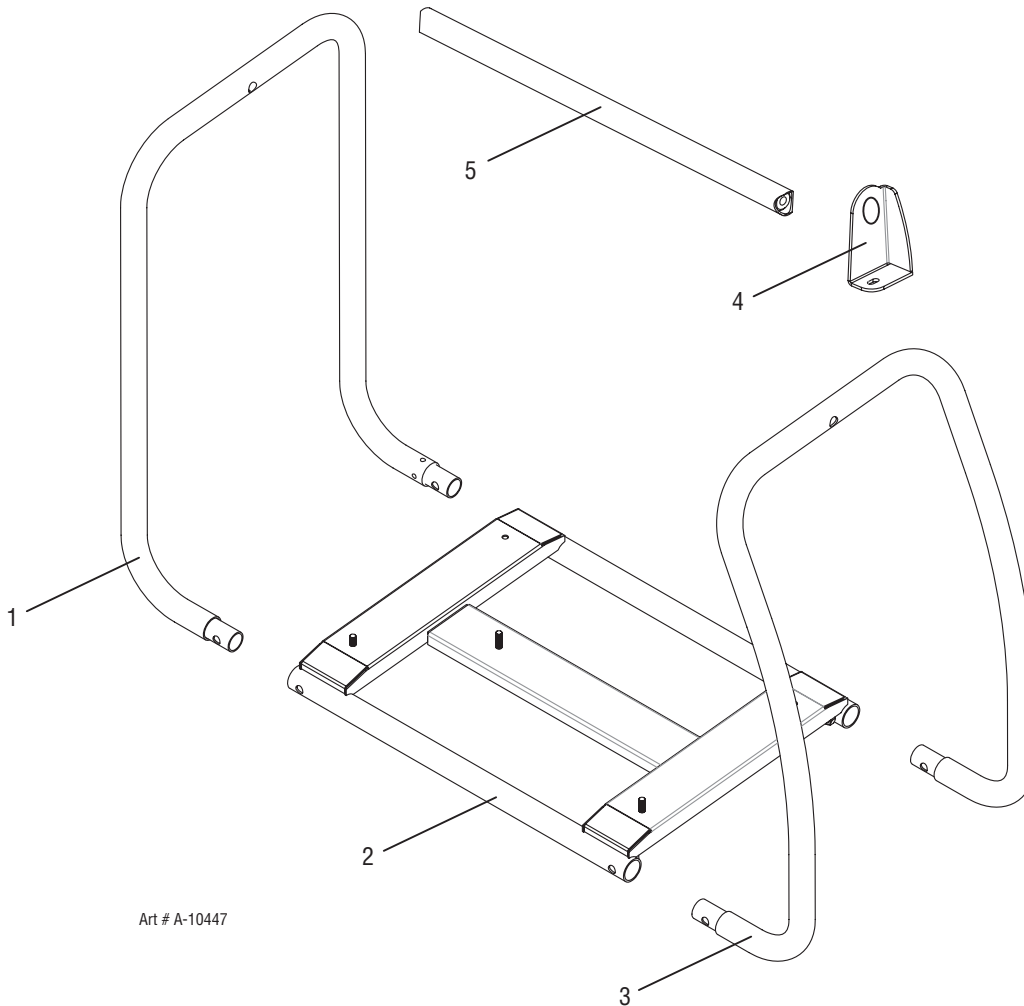

FABRICATOR 211i & 252i ROLL CAGE ASSEMBLY INSTRUCTIONS

A. Mount power source to Base Assembly

1. Open the wire feed compartment door and mount the power source to the Base Assembly (Item 2), carefully aligning the 3 mounting studs in the Base Assembly with the 3 holes in the power source.
2. Fasten all 3 M6 Nuts (Item 9) onto the 3 Base Assembly studs to secure the power source onto the roll cage base.

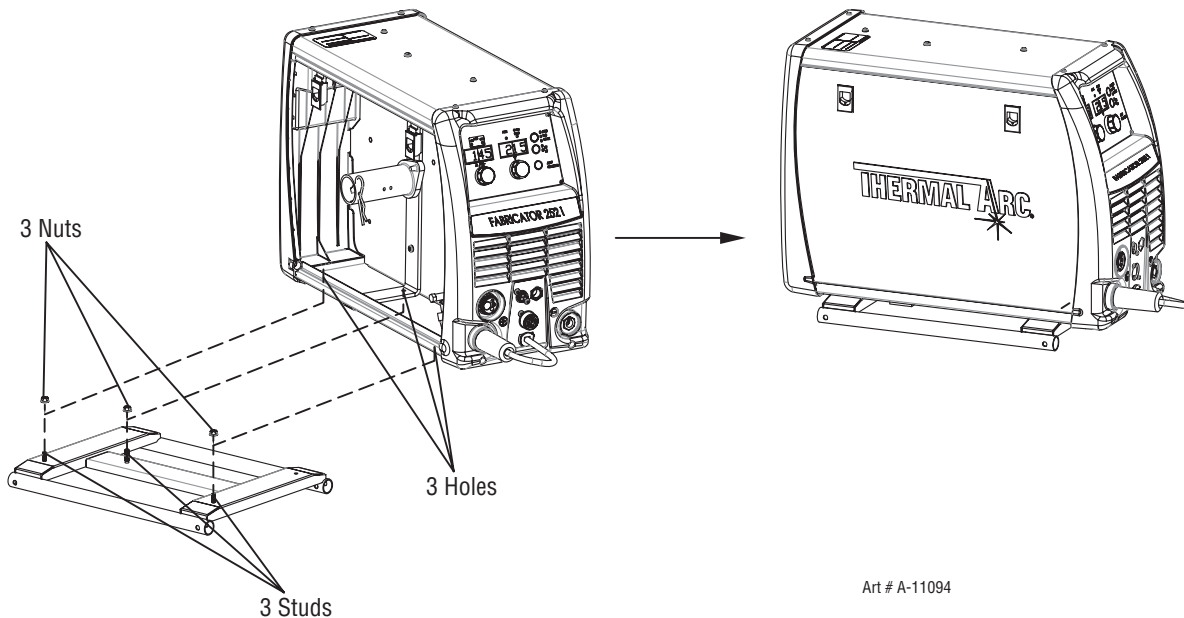

B. Install Front and Rear Frames

1. Install the Rear Frame to the Base Assembly and align Axes A with Axes B.
2. Install the Front Frame to the Base Assembly and align Axes C with Axes D.

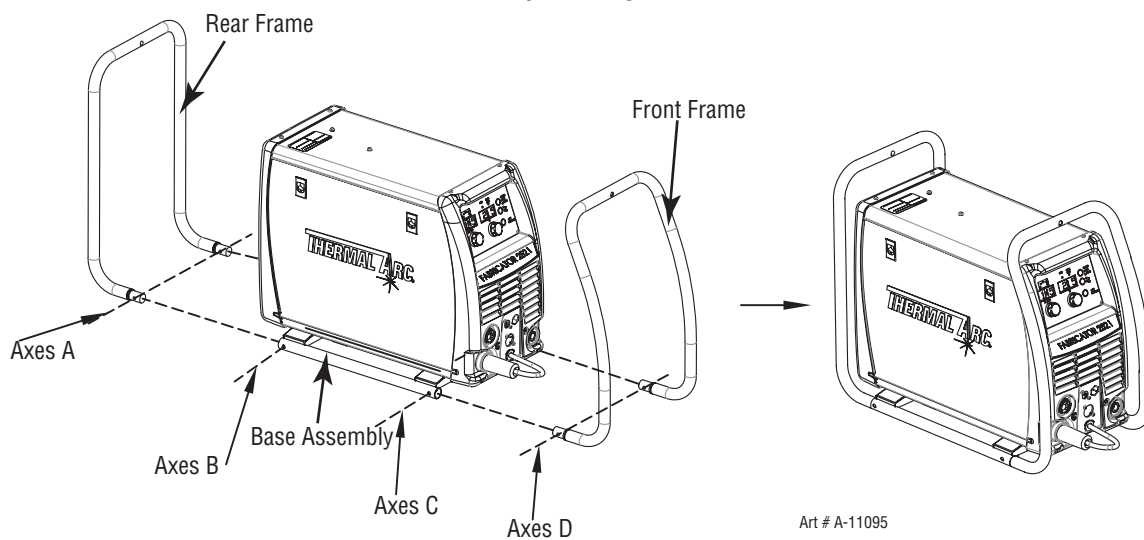

FABRICATOR 211i & 252i ROLL CAGE ASSEMBLY INSTRUCTIONS

3. Fasten the assembled Roll Cage together, using the following hardware:

- Socket Cap Screw (Item 7)
- Saddle Washer (Item 8)

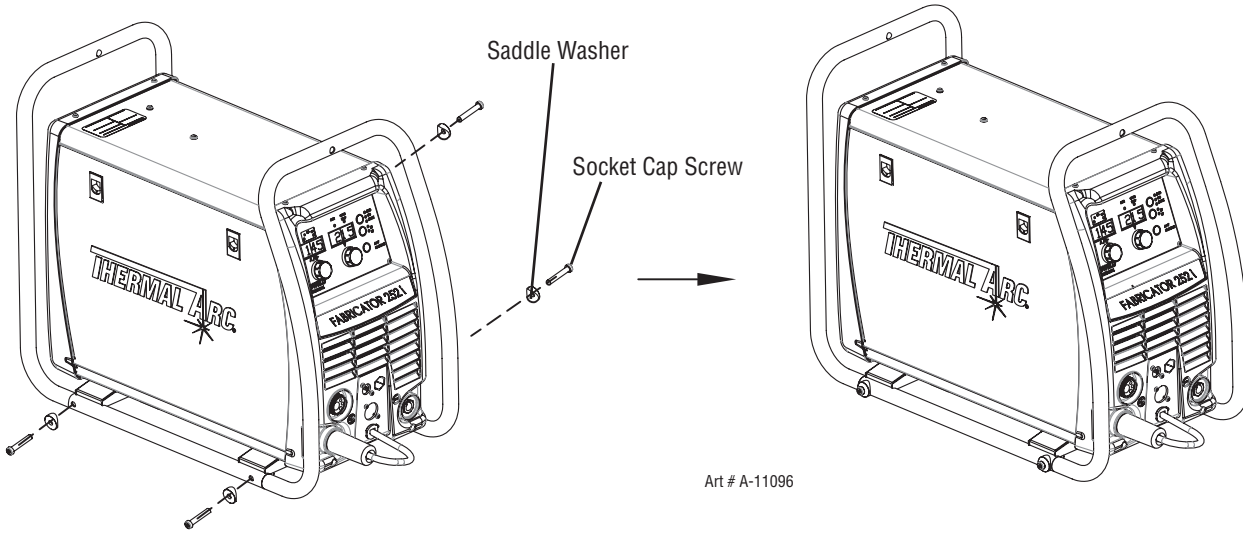
**C. Install Handle to the Roll Cage**

1. Remove the Screw from the top cover using the Torx-Bit T25. Keep this screw as it will be reinstalled later in Step 5.

Specification of the Screw is M6 x 12mm.

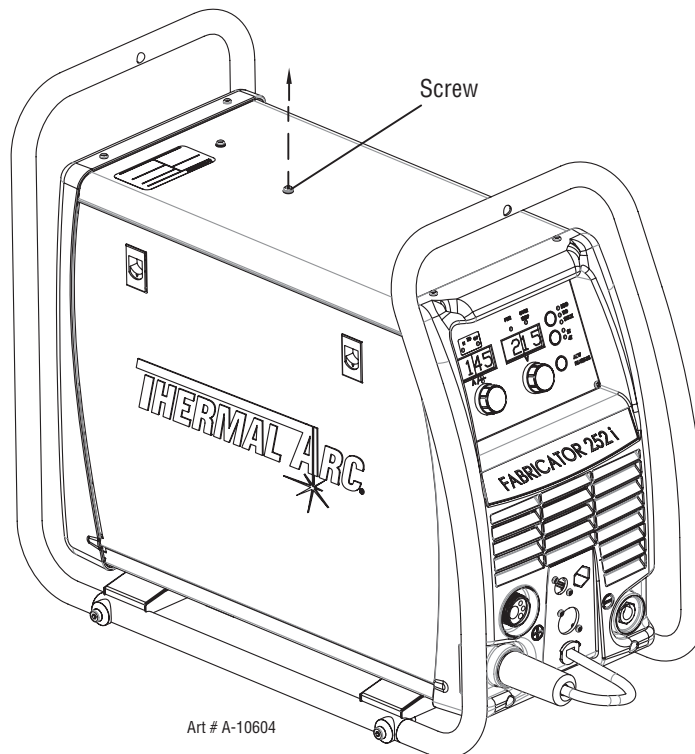

FABRICATOR 211i & 252i ROLL CAGE ASSEMBLY INSTRUCTIONS

2. Insert Handle (Item 5) through hole in Top Support Plate (Item 4).
3. Place the Handle against the Front and Rear Frame with holes on the ends of the Handle aligned with holes on the Frames.
4. Use fasteners to fasten the Handle and the Frames together.

Fasteners are as follows:

- Socket Cap Screw (Item 6)
- Saddle Washer (Item 8)

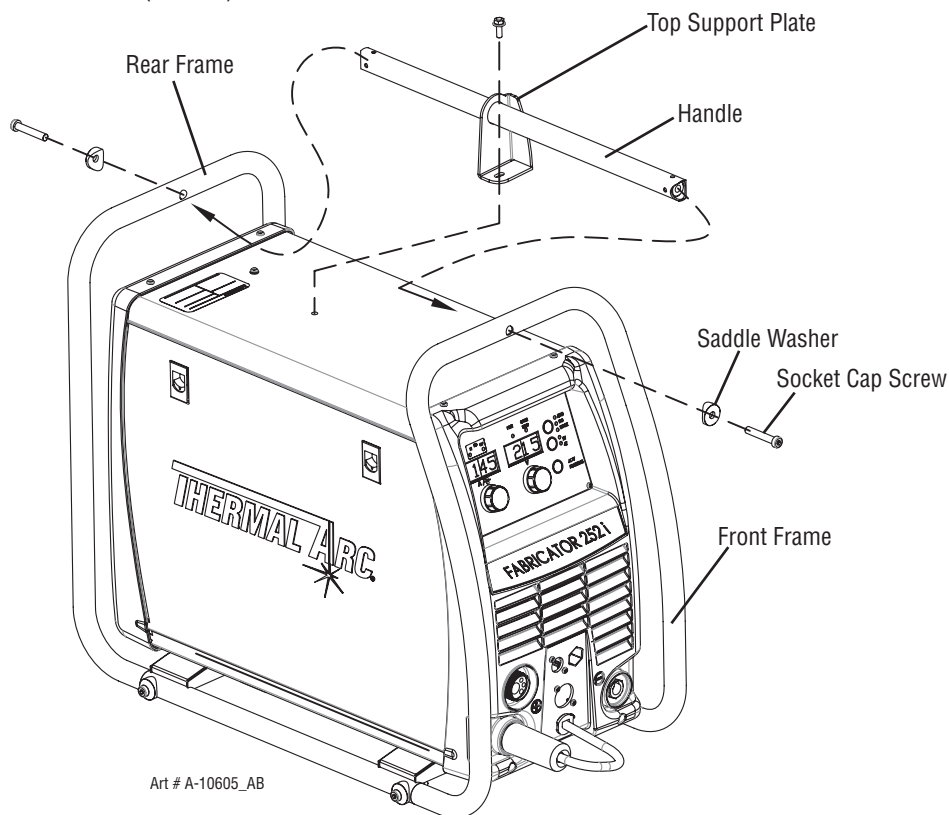

5. Reinstall the Screw (taken out in Step 1) to the Fabricator 211i/252i. Fasten the Screw to secure the power source to the Roll Cage.

FABRICATOR 211i & 252i ROLL CAGE ASSEMBLY INSTRUCTIONS

D. When all the procedures are done, it should look like Figure below:



Fully tighten all the fasteners (refer to torque force data in Supplied Parts section).

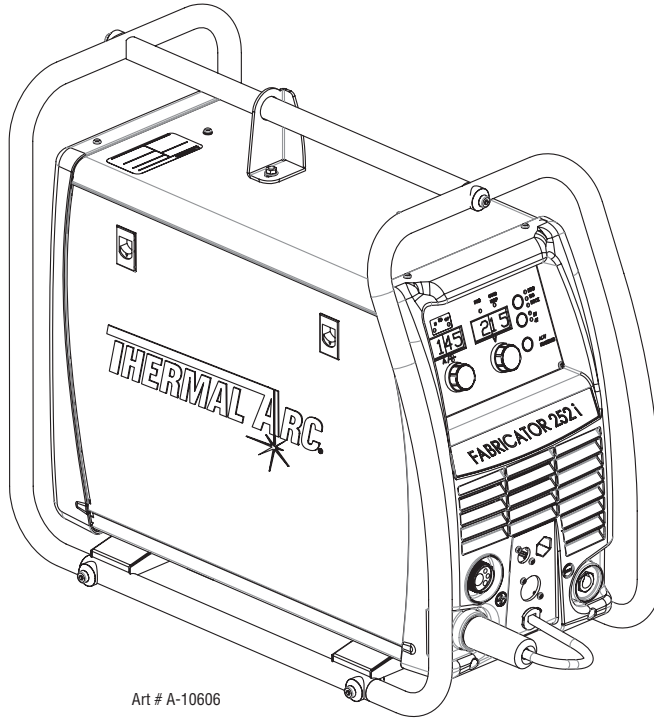

Art # A-10606

FABRICATOR 211i & 252i ROLL CAGE ASSEMBLY INSTRUCTIONS

This page left blank intentionally

Printed in: China

**U.S. Customer Care: 800-426-1888 / FAX 800-535-0557 • Canada Customer Care: 905-827-4515 / FAX 800-588-1714
International Customer Care: 940-381-1212 / FAX 940-483-8178 • www.thermalarc.com**



A Global Cutting & Welding Market Leader™

WORLD HEADQUARTERS: 16052 Swingley Ridge Road, Suite 300 • St. Louis, Missouri 63017 U.S.A.

THE AMERICAS

Denton, TX USA
U.S. Customer Care
Ph: 1-800-426-1888 (tollfree)
Fax: 1-800-535-0557 (tollfree)
International Customer Care
Ph: 1-940-381-1212
Fax: 1-940-483-8178

Miami, FL USA
Sales Office, Latin America
Ph: 1-954-727-8371
Fax: 1-954-727-8376

Oakville, Ontario, Canada
Canada Customer Care
Ph: 1-905-827-4515
Fax: 1-800-588-1714 (tollfree)

EUROPE

Chorley, United Kingdom
Customer Care
Ph: +44 1257-261755
Fax: +44 1257-224800

Milan, Italy
Customer Care
Ph: +39 0236546801
Fax: +39 0236546840

ASIA/PACIFIC

Cikarang, Indonesia
Customer Care
Ph: 6221-8990-6095
Fax: 6221-8990-6096

Rawang, Malaysia
Customer Care
Ph: +603 6092-2988
Fax: +603 6092-1085

Melbourne, Australia
Australia Customer Care
Ph: 1300-654-674 (tollfree)
Ph: 61-3-9474-7400
Fax: 61-3-9474-7391

International
Ph: 61-3-9474-7508
Fax: 61-3-9474-7488

Shanghai, China
Sales Office
Ph: +86 21-64072626
Fax: +86 21-64483032

Singapore
Sales Office
Ph: +65 6832-8066
Fax: +65 6763-5812