



OM-1327

213 814S

2007-01

Processes



MIG (GMAW) Welding
Pulsed MIG (GMAW-P)



Flux Cored (FCAW) Welding

Description



Arc Welding Power Source
and Wire Feeder

Millermatic[®] 350 And Millermatic[®] 350P

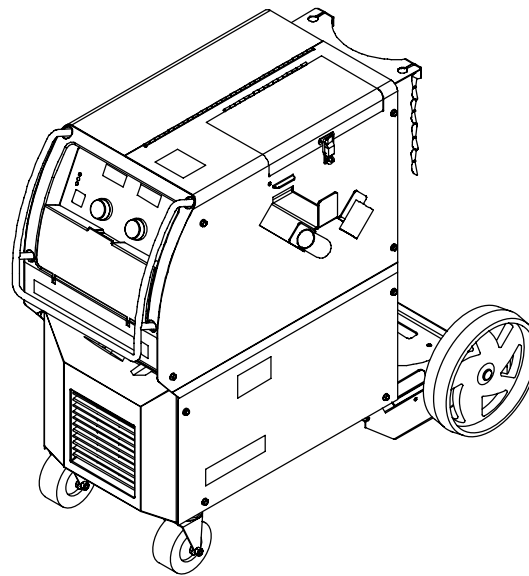

Visit our website at
www.MillerWelds.com

OWNER'S MANUAL

File: MIG (GMAW)



From Miller to You

Thank you and congratulations on choosing Miller. Now you can get the job done and get it done right. We know you don't have time to do it any other way.

That's why when Niels Miller first started building arc welders in 1929, he made sure his products offered long-lasting value and superior quality. Like you, his customers couldn't afford anything less. Miller products had to be more than the best they could be. They had to be the best you could buy.

Today, the people that build and sell Miller products continue the tradition. They're just as committed to providing equipment and service that meets the high standards of quality and value established in 1929.

This Owner's Manual is designed to help you get the most out of your Miller products. Please take time to read the Safety precautions. They will help you protect yourself against potential hazards on the worksite.

We've made installation and operation quick and easy. With Miller you can count on years of reliable service with proper maintenance. And if for some reason the unit needs repair, there's a Troubleshooting section that will help you figure out what the problem is. The parts list will then help you to decide the exact part you may need to fix the problem. Warranty and service information for your particular model are also provided.



Miller is the first welding equipment manufacturer in the U.S.A. to be registered to the ISO 9001:2000 Quality System Standard.

Miller Electric manufactures a full line of welders and welding related equipment. For information on other quality Miller products, contact your local Miller distributor to receive the latest full line catalog or individual specification sheets. **To locate your nearest distributor or service agency call 1-800-4-A-Miller, or visit us at www.MillerWelds.com on the web.**



Working as hard as you do – every power source from Miller is backed by the most hassle-free warranty in the business.



TABLE OF CONTENTS

SECTION 1 – SAFETY PRECAUTIONS - READ BEFORE USING	1
1-1. Symbol Usage	1
1-2. Arc Welding Hazards	1
1-3. Additional Symbols For Installation, Operation, And Maintenance	3
1-4. California Proposition 65 Warnings	3
1-5. Principal Safety Standards	4
1-6. EMF Information	4
SECTION 2 – CONSIGNES DE SÉCURITÉ – LIRE AVANT UTILISATION	5
2-1. Symboles utilisés	5
2-2. Dangers relatifs au soudage à l'arc	5
2-3. Dangers supplémentaires en relation avec l'installation, le fonctionnement et la maintenance	7
2-4. Proposition californienne 65 Avertissements	7
2-5. Principales normes de sécurité	8
2-6. Information EMF	8
SECTION 3 – INSTALLATION	9
3-1. Specifications	9
3-2. Duty Cycle And Overheating	9
3-3. Volt-Ampere Curve	10
3-4. Connecting To Weld Output Terminals	10
3-5. Installing Work Clamp	11
3-6. Installing Welding Gun/Cable Holder	11
3-7. Installing Welding Gun	12
3-8. Connecting Spoolmatic) 15A Or 30A Gun	13
3-9. Connecting XR Edge, XR-A Gun, Or XR-A Python	14
3-10. Setting Gun Polarity For Wire Type	15
3-11. Installing Gas Supply	16
3-12. Installing Wire Spool and Adjusting Hub Tension	16
3-13. Electrical Service Guide	17
3-14. Selecting Input Voltage (200/230/460 Volt Models Only)	18
3-15. Selecting A Location And Connecting 3-Phase Input Power	19
3-16. Selection A Location And Connecting 1-Phase Input Power	20
3-17. Threading Welding Wire For MIG Gun	21
3-18. Threading Welding Wire For XR Edge, XR-A Gun, Or XR-A Python	22
3-19. Threading Welding Wire Through XR Guns	23
SECTION 4 – OPERATION	24
4-1. Controls	24
4-2. MIG Mode	24
4-3. Jog Mode	25
4-4. Weld Status	25
4-5. MIG Gun-On-Demand	25
4-6. Pulse MIG Mode Voltage Adjustment	25
4-7. Pulse MIG Gun-On-Demand	25
4-8. Tip Saver	25
4-9. Weld Parameters For MIG Mode	26
4-10. Weld Parameters For Pulse Mode	27

TABLE OF CONTENTS

SECTION 5 – PROGRAMMING	28
5-1. MIG Welding Mode	28
5-2. Pulse MIG Welding Mode	29
5-3. Timers	30
5-4. Arc Times, Arc Starts, Hot Start (Aluminum Pulse Only), And Crater Fill	31
5-5. Setting Hot Start (Aluminum Pulse Only) Parameters	32
5-6. Setting Crater Fill	33
5-7. Recommended Crater Fill Parameters	34
5-8. System Reset	36
SECTION 6 – MAINTENANCE & TROUBLESHOOTING	37
6-1. Routine Maintenance	37
6-2. Overheating	37
6-3. Measuring Input Capacitor Voltage	38
6-4. Changing Drive Roll and Wire Inlet Guide	39
6-5. Troubleshooting	40
6-6. Help Displays	41
SECTION 7 – ELECTRICAL DIAGRAM	44
SECTION 8 – PARTS LIST	48
WARRANTY	

SECTION 1 – SAFETY PRECAUTIONS - READ BEFORE USING

som _3/05

▲ **Warning: Protect yourself and others from injury — read and follow these precautions.**

1-1. Symbol Usage



Means Warning! Watch Out! There are possible hazards with this procedure! The possible hazards are shown in the adjoining symbols.

▲ **Marks a special safety message.**

☞ Means "Note"; not safety related.



This group of symbols means Warning! Watch Out! possible ELECTRIC SHOCK, MOVING PARTS, and HOT PARTS hazards. Consult symbols and related instructions below for necessary actions to avoid the hazards.

1-2. Arc Welding Hazards

▲ **The symbols shown below are used throughout this manual to call attention to and identify possible hazards. When you see the symbol, watch out, and follow the related instructions to avoid the hazard. The safety information given below is only a summary of the more complete safety information found in the Safety Standards listed in Section 1-5. Read and follow all Safety Standards.**

▲ **Only qualified persons should install, operate, maintain, and repair this unit.**

▲ **During operation, keep everybody, especially children, away.**



ELECTRIC SHOCK can kill.

Touching live electrical parts can cause fatal shocks or severe burns. The electrode and work circuit is electrically live whenever the output is on. The input power circuit and machine internal circuits are also

live when power is on. In semiautomatic or automatic wire welding, the wire, wire reel, drive roll housing, and all metal parts touching the welding wire are electrically live. Incorrectly installed or improperly grounded equipment is a hazard.

- Do not touch live electrical parts.
- Wear dry, hole-free insulating gloves and body protection.
- Insulate yourself from work and ground using dry insulating mats or covers big enough to prevent any physical contact with the work or ground.
- Do not use AC output in damp areas, if movement is confined, or if there is a danger of falling.
- Use AC output ONLY if required for the welding process.
- If AC output is required, use remote output control if present on unit.
- Additional safety precautions are required when any of the following electrically hazardous conditions are present: in damp locations or while wearing wet clothing; on metal structures such as floors, gratings, or scaffolds; when in cramped positions such as sitting, kneeling, or lying; or when there is a high risk of unavoidable or accidental contact with the workpiece or ground. For these conditions, use the following equipment in order presented: 1) a semiautomatic DC constant voltage (wire) welder, 2) a DC manual (stick) welder, or 3) an AC welder with reduced open-circuit voltage. In most situations, use of a DC, constant voltage wire welder is recommended. And, do not work alone!
- Disconnect input power or stop engine before installing or servicing this equipment. Lockout/tagout input power according to OSHA 29 CFR 1910.147 (see Safety Standards).
- Properly install and ground this equipment according to its Owner's Manual and national, state, and local codes.
- Always verify the supply ground – check and be sure that input power cord ground wire is properly connected to ground terminal in disconnect box or that cord plug is connected to a properly grounded receptacle outlet.
- When making input connections, attach proper grounding conductor first – double-check connections.
- Frequently inspect input power cord for damage or bare wiring – replace cord immediately if damaged – bare wiring can kill.

- Turn off all equipment when not in use.
- Do not use worn, damaged, undersized, or poorly spliced cables.
- Do not drape cables over your body.
- If earth grounding of the workpiece is required, ground it directly with a separate cable.
- Do not touch electrode if you are in contact with the work, ground, or another electrode from a different machine.
- Do not touch electrode holders connected to two welding machines at the same time since double open-circuit voltage will be present.
- Use only well-maintained equipment. Repair or replace damaged parts at once. Maintain unit according to manual.
- Wear a safety harness if working above floor level.
- Keep all panels and covers securely in place.
- Clamp work cable with good metal-to-metal contact to workpiece or worktable as near the weld as practical.
- Insulate work clamp when not connected to workpiece to prevent contact with any metal object.
- Do not connect more than one electrode or work cable to any single weld output terminal.

SIGNIFICANT DC VOLTAGE exists in inverter-type welding power sources after removal of input power.

- Turn Off inverter, disconnect input power, and discharge input capacitors according to instructions in Maintenance Section before touching any parts.

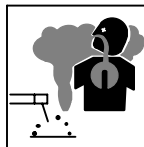

FUMES AND GASES can be hazardous.

Welding produces fumes and gases. Breathing these fumes and gases can be hazardous to your health.

- Keep your head out of the fumes. Do not breathe the fumes.
- If inside, ventilate the area and/or use local forced ventilation at the arc to remove welding fumes and gases.
- If ventilation is poor, wear an approved air-supplied respirator.
- Read and understand the Material Safety Data Sheets (MSDSs) and the manufacturer's instructions for metals, consumables, coatings, cleaners, and degreasers.
- Work in a confined space only if it is well ventilated, or while wearing an air-supplied respirator. Always have a trained watch-person nearby. Welding fumes and gases can displace air and lower the oxygen level causing injury or death. Be sure the breathing air is safe.
- Do not weld in locations near degreasing, cleaning, or spraying operations. The heat and rays of the arc can react with vapors to form highly toxic and irritating gases.
- Do not weld on coated metals, such as galvanized, lead, or cadmium plated steel, unless the coating is removed from the weld area, the area is well ventilated, and while wearing an air-supplied respirator. The coatings and any metals containing these elements can give off toxic fumes if welded.



ARC RAYS can burn eyes and skin.

Arc rays from the welding process produce intense visible and invisible (ultraviolet and infrared) rays that can burn eyes and skin. Sparks fly off from the weld.

- Wear an approved welding helmet fitted with a proper shade of filter lenses to protect your face and eyes when welding or watching (see ANSI Z49.1 and Z87.1 listed in Safety Standards).
- Wear approved safety glasses with side shields under your helmet.
- Use protective screens or barriers to protect others from flash, glare and sparks; warn others not to watch the arc.
- Wear protective clothing made from durable, flame-resistant material (leather, heavy cotton, or wool) and foot protection.



WELDING can cause fire or explosion.

Welding on closed containers, such as tanks, drums, or pipes, can cause them to blow up. Sparks can fly off from the welding arc. The flying sparks, hot workpiece, and hot equipment can cause fires and burns. Accidental contact of electrode to metal objects can cause sparks, explosion, overheating, or fire. Check and be sure the area is safe before doing any welding.

- Remove all flammables within 35 ft (10.7 m) of the welding arc. If this is not possible, tightly cover them with approved covers.
- Do not weld where flying sparks can strike flammable material.
- Protect yourself and others from flying sparks and hot metal.
- Be alert that welding sparks and hot materials from welding can easily go through small cracks and openings to adjacent areas.
- Watch for fire, and keep a fire extinguisher nearby.
- Be aware that welding on a ceiling, floor, bulkhead, or partition can cause fire on the hidden side.
- Do not weld on closed containers such as tanks, drums, or pipes, unless they are properly prepared according to AWS F4.1 (see Safety Standards).
- Connect work cable to the work as close to the welding area as practical to prevent welding current from traveling long, possibly unknown paths and causing electric shock, sparks, and fire hazards.
- Do not use welder to thaw frozen pipes.
- Remove stick electrode from holder or cut off welding wire at contact tip when not in use.
- Wear oil-free protective garments such as leather gloves, heavy shirt, cuffless trousers, high shoes, and a cap.
- Remove any combustibles, such as a butane lighter or matches, from your person before doing any welding.
- Follow requirements in OSHA 1910.252 (a) (2) (iv) and NFPA 51B for hot work and have a fire watcher and extinguisher nearby.

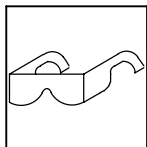

FLYING METAL can injure eyes.

- Welding, chipping, wire brushing, and grinding cause sparks and flying metal. As welds cool, they can throw off slag.
- Wear approved safety glasses with side shields even under your welding helmet.



BUILDUP OF GAS can injure or kill.

- Shut off shielding gas supply when not in use.
- Always ventilate confined spaces or use approved air-supplied respirator.



HOT PARTS can cause severe burns.

- Do not touch hot parts bare handed.
- Allow cooling period before working on gun or torch.
- To handle hot parts, use proper tools and/or wear heavy, insulated welding gloves and clothing to prevent burns.

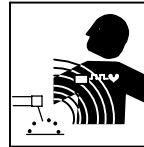

MAGNETIC FIELDS can affect pacemakers.

- Pacemaker wearers keep away.
- Wearers should consult their doctor before going near arc welding, gouging, or spot welding operations.

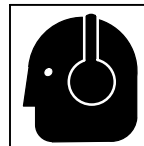

NOISE can damage hearing.

Noise from some processes or equipment can damage hearing.

- Wear approved ear protection if noise level is high.

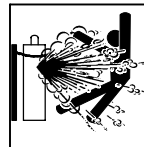

CYLINDERS can explode if damaged.

Shielding gas cylinders contain gas under high pressure. If damaged, a cylinder can explode. Since gas cylinders are normally part of the welding process, be sure to treat them carefully.

- Protect compressed gas cylinders from excessive heat, mechanical shocks, physical damage, slag, open flames, sparks, and arcs.
- Install cylinders in an upright position by securing to a stationary support or cylinder rack to prevent falling or tipping.
- Keep cylinders away from any welding or other electrical circuits.
- Never drape a welding torch over a gas cylinder.
- Never allow a welding electrode to touch any cylinder.
- Never weld on a pressurized cylinder – explosion will result.
- Use only correct shielding gas cylinders, regulators, hoses, and fittings designed for the specific application; maintain them and associated parts in good condition.
- Turn face away from valve outlet when opening cylinder valve.
- Keep protective cap in place over valve except when cylinder is in use or connected for use.
- Use the right equipment, correct procedures, and sufficient number of persons to lift and move cylinders.
- Read and follow instructions on compressed gas cylinders, associated equipment, and Compressed Gas Association (CGA) publication P-1 listed in Safety Standards.

1-3. Additional Symbols For Installation, Operation, And Maintenance



FIRE OR EXPLOSION hazard.

- Do not install or place unit on, over, or near combustible surfaces.
- Do not install unit near flammables.
- Do not overload building wiring – be sure power supply system is properly sized, rated, and protected to handle this unit.



FALLING UNIT can cause injury.

- Use lifting eye to lift unit only, NOT running gear, gas cylinders, or any other accessories.
- Use equipment of adequate capacity to lift and support unit.
- If using lift forks to move unit, be sure forks are long enough to extend beyond opposite side of unit.



OVERUSE can cause OVERHEATING

- Allow cooling period; follow rated duty cycle.
- Reduce current or reduce duty cycle before starting to weld again.
- Do not block or filter airflow to unit.



STATIC (ESD) can damage PC boards.

- Put on grounded wrist strap BEFORE handling boards or parts.
- Use proper static-proof bags and boxes to store, move, or ship PC boards.



MOVING PARTS can cause injury.

- Keep away from moving parts.
- Keep away from pinch points such as drive rolls.



WELDING WIRE can cause injury.

- Do not press gun trigger until instructed to do so.
- Do not point gun toward any part of the body, other people, or any metal when threading welding wire.



MOVING PARTS can cause injury.

- Keep away from moving parts such as fans.
- Keep all doors, panels, covers, and guards closed and securely in place.
- Have only qualified persons remove doors, panels, covers, or guards for maintenance as necessary.
- Reinstall doors, panels, covers, or guards when maintenance is finished and before re-connecting input power.



READ INSTRUCTIONS.

- Read Owner's Manual before using or servicing unit.
- Use only genuine Miller/Hobart replacement parts.

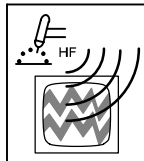

H.F. RADIATION can cause interference.

- High-frequency (H.F.) can interfere with radio navigation, safety services, computers, and communications equipment.
- Have only qualified persons familiar with electronic equipment perform this installation.
- The user is responsible for having a qualified electrician promptly correct any interference problem resulting from the installation.
- If notified by the FCC about interference, stop using the equipment at once.
- Have the installation regularly checked and maintained.
- Keep high-frequency source doors and panels tightly shut, keep spark gaps at correct setting, and use grounding and shielding to minimize the possibility of interference.



ARC WELDING can cause interference.

- Electromagnetic energy can interfere with sensitive electronic equipment such as computers and computer-driven equipment such as robots.
- Be sure all equipment in the welding area is electromagnetically compatible.
- To reduce possible interference, keep weld cables as short as possible, close together, and down low, such as on the floor.
- Locate welding operation 100 meters from any sensitive electronic equipment.
- Be sure this welding machine is installed and grounded according to this manual.
- If interference still occurs, the user must take extra measures such as moving the welding machine, using shielded cables, using line filters, or shielding the work area.

1-4. California Proposition 65 Warnings

- ▲ **Welding or cutting equipment produces fumes or gases which contain chemicals known to the State of California to cause birth defects and, in some cases, cancer. (California Health & Safety Code Section 25249.5 et seq.)**
- ▲ **Battery posts, terminals and related accessories contain lead and lead compounds, chemicals known to the State of California to cause cancer and birth defects or other reproductive harm. Wash hands after handling.**

For Gasoline Engines:

- ▲ **Engine exhaust contains chemicals known to the State of California to cause cancer, birth defects, or other reproductive harm.**

For Diesel Engines:

- ▲ **Diesel engine exhaust and some of its constituents are known to the State of California to cause cancer, birth defects, and other reproductive harm.**

1-5. Principal Safety Standards

Safety in Welding, Cutting, and Allied Processes, ANSI Standard Z49.1, from Global Engineering Documents (phone: 1-877-413-5184, website: www.global.ihs.com).

Recommended Safe Practices for the Preparation for Welding and Cutting of Containers and Piping, American Welding Society Standard AWS F4.1 from Global Engineering Documents (phone: 1-877-413-5184, website: www.global.ihs.com).

National Electrical Code, NFPA Standard 70, from National Fire Protection Association, P.O. Box 9101, 1 Battery March Park, Quincy, MA 02269-9101 (phone: 617-770-3000, website: www.nfpa.org).

Safe Handling of Compressed Gases in Cylinders, CGA Pamphlet P-1, from Compressed Gas Association, 1735 Jefferson Davis Highway, Suite 1004, Arlington, VA 22202-4102 (phone: 703-412-0900, website: www.cganet.com).

Code for Safety in Welding and Cutting, CSA Standard W117.2, from Canadian Standards Association, Standards Sales, 178 Rexdale

Boulevard, Rexdale, Ontario, Canada M9W 1R3 (phone: 800-463-6727 or in Toronto 416-747-4044, website: www.csa-international.org).

Practice For Occupational And Educational Eye And Face Protection, ANSI Standard Z87.1, from American National Standards Institute, 11 West 42nd Street, New York, NY 10036-8002 (phone: 212-642-4900, website: www.ansi.org).

Standard for Fire Prevention During Welding, Cutting, and Other Hot Work, NFPA Standard 51B, from National Fire Protection Association, P.O. Box 9101, 1 Battery March Park, Quincy, MA 02269-9101 (phone: 617-770-3000, website: www.nfpa.org).

OSHA, Occupational Safety and Health Standards for General Industry, Title 29, Code of Federal Regulations (CFR), Part 1910, Subpart Q, and Part 1926, Subpart J, from U.S. Government Printing Office, Superintendent of Documents, P.O. Box 371954, Pittsburgh, PA 15250 (there are 10 Regional Offices—phone for Region 5, Chicago, is 312-353-2220, website: www.osha.gov).

1-6. EMF Information

Considerations About Welding And The Effects Of Low Frequency Electric And Magnetic Fields

Welding current, as it flows through welding cables, will cause electromagnetic fields. There has been and still is some concern about such fields. However, after examining more than 500 studies spanning 17 years of research, a special blue ribbon committee of the National Research Council concluded that: "The body of evidence, in the committee's judgment, has not demonstrated that exposure to power-frequency electric and magnetic fields is a human-health hazard." However, studies are still going forth and evidence continues to be examined. Until the final conclusions of the research are reached, you may wish to minimize your exposure to electromagnetic fields when welding or cutting.

To reduce magnetic fields in the workplace, use the following procedures:

1. Keep cables close together by twisting or taping them.
2. Arrange cables to one side and away from the operator.
3. Do not coil or drape cables around your body.
4. Keep welding power source and cables as far away from operator as practical.
5. Connect work clamp to workpiece as close to the weld as possible.

About Pacemakers:

Pacemaker wearers consult your doctor before welding or going near welding operations. If cleared by your doctor, then following the above procedures is recommended.

SECTION 2 – CONSIGNES DE SÉCURITÉ – LIRE AVANT UTILISATION

fre_som _3/05

▲ **Avertissement : se protéger et protéger les autres contre le risque de blessure — lire et respecter ces consignes.**

2-1. Symboles utilisés



Symbole graphique d'avertissement ! Attention ! Cette procédure comporte des risques possibles ! Les dangers éventuels sont représentés par les symboles graphiques joints.



Ce groupe de symboles signifie Avertissement ! Attention ! Risques d'ÉLECTROCUTION, ORGANES MOBILES et PARTIES CHAUDES. Consulter les symboles et les instructions afférentes ci-dessous concernant les mesures à prendre pour supprimer les dangers.

▲ **Indique un message de sécurité particulier**

☞ Signifie NOTE ; n'est pas relatif à la sécurité.

2-2. Dangers relatifs au soudage à l'arc

▲ **Les symboles représentés ci-dessous sont utilisés dans ce manuel pour attirer l'attention et identifier les dangers possibles. En présence de l'un de ces symboles, prendre garde et suivre les instructions afférentes pour éviter tout risque. Les instructions en matière de sécurité indiquées ci-dessous ne constituent qu'un sommaire des instructions de sécurité plus complètes fournies dans les normes de sécurité énumérées dans la Section 2-5. Lire et observer toutes les normes de sécurité.**

▲ **Seul un personnel qualifié est autorisé à installer, faire fonctionner, entretenir et réparer cet appareil.**

▲ **Pendant le fonctionnement, maintenir à distance toutes les personnes, notamment les enfants de l'appareil.**



UNE DÉCHARGE ÉLECTRIQUE peut entraîner la mort.

Le contact d'organes électriques sous tension peut provoquer des accidents mortels ou des brûlures graves. Le circuit de l'électrode et de la pièce est sous tension lorsque le courant est délivré à la sortie. Le circuit d'alimentation et les circuits internes de la machine sont également sous tension lorsque l'alimentation est sur Marche. Dans le mode de soudage avec du fil, le fil, le dérouleur, le bloc de commande du rouleau et toutes les parties métalliques en contact avec le fil sont sous tension électrique. Un équipement installé ou mis à la terre de manière incorrecte ou impropre constitue un danger.

- Ne pas toucher aux pièces électriques sous tension.
- Porter des gants isolants et des vêtements de protection secs et sans trous.
- S'isoler de la pièce à couper et du sol en utilisant des housses ou des tapis assez grands afin d'éviter tout contact physique avec la pièce à couper ou le sol.
- Ne pas se servir de source électrique à courant électrique dans les zones humides, dans les endroits confinés ou là où on risque de tomber.
- Se servir d'une source électrique à courant électrique UNIQUEMENT si le procédé de soudage le demande.
- Si l'utilisation d'une source électrique à courant électrique s'avère nécessaire, se servir de la fonction de télécommande si l'appareil en est équipé.
- D'autres consignes de sécurité sont nécessaires dans les conditions suivantes : risques électriques dans un environnement humide ou si l'on porte des vêtements mouillés ; sur des structures métalliques telles que sols, grilles ou échafaudages ; en position coincée comme assise, à genoux ou couchée ; ou s'il y a un risque élevé de contact inévitable ou accidentel avec la pièce à souder ou le sol. Dans ces conditions, utiliser les équipements suivants, dans l'ordre indiqué : 1) un poste à souder DC à tension constante (à fil), 2) un poste à souder DC manuel (électrode) ou 3) un poste à souder AC à tension à vide réduite. Dans la plupart des situations, l'utilisation d'un poste à souder DC à fil à tension constante est recommandée. En outre, ne pas travailler seul !
- Couper l'alimentation ou arrêter le moteur avant de procéder à l'installation, à la réparation ou à l'entretien de l'appareil. Déverrouiller l'alimentation selon la norme OSHA 29 CFR 1910.147 (voir normes de sécurité).
- Installer le poste correctement et le mettre à la terre convenablement selon les consignes du manuel de l'opérateur et les normes nationales, provinciales et locales.
- Toujours vérifier la terre du cordon d'alimentation. Vérifier et s'assurer que le fil de terre du cordon d'alimentation est bien raccordé à la borne de terre du sectionneur ou que la fiche du cordon est raccordée à une prise correctement mise à la terre.
- En effectuant les raccordements d'entrée, fixer d'abord le conducteur de mise à la terre approprié et contre-vérifier les connexions.

- Vérifier fréquemment le cordon d'alimentation afin de s'assurer qu'il n'est pas altéré ou à nu, le remplacer immédiatement s'il l'est. Un fil à nu peut entraîner la mort.
- L'équipement doit être hors tension lorsqu'il n'est pas utilisé.
- Ne pas utiliser des câbles usés, endommagés, de grosseur insuffisante ou mal épluchés.
- Ne pas enrouler les câbles autour du corps.
- Si la pièce soudée doit être mise à la terre, le faire directement avec un câble distinct.
- Ne pas toucher l'électrode quand on est en contact avec la pièce, la terre ou une électrode provenant d'une autre machine.
- Ne pas toucher des porte électrodes connectés à deux machines en même temps à cause de la présence d'une tension à vide doublée.
- N'utiliser qu'un matériel en bon état. Réparer ou remplacer sur-le-champ les pièces endommagées. Entretien l'appareil conformément à ce manuel.
- Porter un harnais de sécurité si l'on doit travailler au-dessus du sol.
- S'assurer que tous les panneaux et couvercles sont correctement en place.
- Fixer le câble de retour de façon à obtenir un bon contact métal-métal avec la pièce à souder ou la table de travail, le plus près possible de la soudure.
- Isoler la pince de masse quand pas mis à la pièce pour éviter le contact avec tout objet métallique.
- Ne pas raccorder plus d'une électrode ou plus d'un câble de masse à une même borne de sortie de soudage.

Il reste une TENSION DC NON NÉGLIGEABLE dans les sources de soudage onduleur quand on a coupé l'alimentation.

- Arrêter les convertisseurs, débrancher le courant électrique et décharger les condensateurs d'alimentation selon les instructions indiquées dans la partie Entretien avant de toucher les pièces.

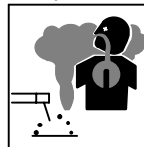

LES FUMÉES ET LES GAZ peuvent être dangereux.

Le soudage génère des fumées et des gaz. Leur inhalation peut être dangereuse pour la santé.

- Ne pas mettre sa tête au-dessus des vapeurs. Ne pas respirer ces vapeurs.
- À l'intérieur, ventiler la zone et/ou utiliser une ventilation forcée au niveau de l'arc pour l'évacuation des fumées et des gaz de soudage.
- Si la ventilation est médiocre, porter un respirateur anti-vapeurs approuvé.
- Lire et comprendre les spécifications de sécurité des matériaux (MSDS) et les instructions du fabricant concernant les métaux, les consommables, les revêtements, les nettoyeurs et les dégraisseurs.
- Travailler dans un espace fermé seulement s'il est bien ventilé ou en portant un respirateur à alimentation d'air. Demander toujours à un surveillant dûment formé de se tenir à proximité. Des fumées et des gaz de soudage peuvent déplacer l'air et abaisser le niveau d'oxygène provoquant des blessures ou des accidents mortels. S'assurer que l'air de respiration ne présente aucun danger.
- Ne pas souder dans des endroits situés à proximité d'opérations de dégraissage, de nettoyage ou de pulvérisation. La chaleur et les rayons de l'arc peuvent réagir en présence de vapeurs et former des gaz hautement toxiques et irritants.
- Ne pas souder des métaux munis d'un revêtement, tels que l'acier galvanisé, plaqué en plomb ou au cadmium à moins que le revêtement n'ait été enlevé dans la zone de soudure, que l'endroit soit bien ventilé et en portant un respirateur à alimentation d'air. Les revêtements et tous les métaux renfermant ces éléments peuvent dégager des fumées toxiques en cas de soudage.



LES RAYONS D'ARC peuvent entraîner des brûlures aux yeux et à la peau.

Le rayonnement de l'arc du procédé de soudage génère des rayons visibles et invisibles intenses (ultraviolets et infrarouges) susceptibles de provoquer des brûlures dans les yeux et sur la peau.

Des étincelles sont projetées pendant le soudage.

- Porter un casque de soudage approuvé muni de verres filtrants appropriés pour protéger visage et yeux pendant le soudage (voir ANSI Z49.1 et Z87.1 énumérés dans les normes de sécurité).
- Porter des lunettes de sécurité avec écrans latéraux même sous votre casque.
- Avoir recours à des écrans protecteurs ou à des rideaux pour protéger les autres contre les rayonnements les éblouissements et les étincelles ; prévenir toute personne sur les lieux de ne pas regarder l'arc.
- Porter des vêtements confectionnés avec des matières résistantes et ignifuges (cuir, coton lourd ou laine) et des bottes de protection.



LE SOUDAGE peut provoquer un incendie ou une explosion.

Le soudage effectué sur des conteneurs fermés tels que des réservoirs, tambours ou des conduites peut provoquer leur éclatement. Des étincelles peuvent être projetées de l'arc de soudure. La projection d'étincelles, des pièces chaudes et des équipements chauds peuvent provoquer des incendies et des brûlures. Le contact accidentel de l'électrode avec des objets métalliques peut provoquer des étincelles, une explosion, une surchauffe ou un incendie. Avant de commencer le soudage, vérifier et s'assurer que l'endroit ne présente pas de danger.

- Déplacer toutes les substances inflammables à une distance de 10,7 m de l'arc de soudage. En cas d'impossibilité, les recouvrir soigneusement avec des protections homologuées.
- Ne pas souder dans un endroit où des étincelles peuvent tomber sur des substances inflammables.
- Se protéger, ainsi que toute autre personne travaillant sur les lieux, contre les étincelles et le métal chaud.
- Des étincelles et des matériaux chauds du soudage peuvent facilement passer dans d'autres zones en traversant de petites fissures et des ouvertures.
- Afin d'éliminer tout risque de feu, être vigilant et garder toujours un extincteur à la portée de main.
- Le soudage effectué sur un plafond, plancher, paroi ou séparation peut déclencher un incendie de l'autre côté.
- Ne pas effectuer le soudage sur des conteneurs fermés tels que des réservoirs, tambours, ou conduites, à moins qu'ils n'aient été préparés correctement conformément à AWS F4.1 (voir les normes de sécurité).
- Brancher le câble de masse sur la pièce la plus près possible de la zone de soudage pour éviter le transport du courant sur une longue distance par des chemins inconnus éventuels en provoquant des risques d'électrocution, d'étincelles et d'incendie.
- Ne pas utiliser le poste de soudage pour décongeler des conduites gelées.
- En cas de non-utilisation, enlever la baguette d'électrode du porte-électrode ou couper le fil à la pointe de contact.
- Porter des vêtements de protection exempts d'huile tels que des gants en cuir, une veste résistante, des pantalons sans revers, des bottes et un casque.
- Avant de souder, retirer toute substance combustible de ses poches telles qu'un allumeur au butane ou des allumettes.
- Suivre les consignes de OSHA 1910.252 (a) (2) (iv) et de NFPA 51B pour travaux de soudage et prévoir un détecteur d'incendie et un extincteur à proximité.



DES PARTICULES VOLANTES peuvent blesser les yeux.

- Le soudage, l'écaillage, le passage de la pièce à la brosse en fil de fer, et le meulage génèrent des étincelles et des particules métalliques volantes. Pendant la période de refroidissement des soudures, elles risquent de projeter du laitier.
- Porter des lunettes de sécurité avec écrans latéraux ou un écran facial.



LES ACCUMULATIONS DE GAZ risquent de provoquer des blessures ou même la mort.

- Fermer l'alimentation du gaz protecteur en cas de non-utilisation.
- Veiller toujours à bien aérer les espaces confinés ou se servir d'un respirateur d'adduction d'air homologué.



DES PIÈCES CHAUDES peuvent provoquer des brûlures graves.

- Ne pas toucher des parties chaudes à mains nues.
- Prévoir une période de refroidissement avant d'utiliser le pistolet ou la torche.
- Ne pas toucher aux pièces chaudes, utiliser les outils recommandés et porter des gants de soudage et des vêtements épais pour éviter les brûlures.



LES CHAMPS MAGNÉTIQUES peuvent affecter les stimulateurs cardiaques.

- Porteurs de stimulateur cardiaque, rester à distance.
- Les porteurs d'un stimulateur cardiaque doivent d'abord consulter leur médecin avant de s'approcher des opérations de soudage à l'arc, de gougeage ou de soudage par points.

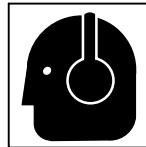

LE BRUIT peut endommager l'ouïe.

Le bruit des processus et des équipements peut affecter l'ouïe.

- Porter des protections approuvées pour les oreilles si le niveau sonore est trop élevé.



LES BOUTEILLES peuvent exploser si elles sont endommagées.

Des bouteilles de gaz protecteur contiennent du gaz sous haute pression. Si une bouteille est endommagée, elle peut exploser. Du fait que les bouteilles de gaz font normalement partie du procédé de soudage, les manipuler avec précaution.

- Protéger les bouteilles de gaz comprimé d'une chaleur excessive, des chocs mécaniques, des dommages physiques, du laitier, des flammes ouvertes, des étincelles et des arcs.
- Placer les bouteilles debout en les fixant dans un support stationnaire ou dans un porte-bouteilles pour les empêcher de tomber ou de se renverser.
- Tenir les bouteilles éloignées des circuits de soudage ou autres circuits électriques.
- Ne jamais placer une torche de soudage sur une bouteille à gaz.
- Une électrode de soudage ne doit jamais entrer en contact avec une bouteille.
- Ne jamais souder une bouteille pressurisée – risque d'explosion.
- Utiliser seulement des bouteilles de gaz protecteur, régulateurs, tuyaux et raccords convenables pour cette application spécifique ; les maintenir ainsi que les éléments associés en bon état.
- Détourner votre visage du détendeur-régulateur lorsque vous ouvrez la soupape de la bouteille.
- Le couvercle du détendeur doit toujours être en place, sauf lorsque la bouteille est utilisée ou qu'elle est reliée pour usage ultérieur.
- Utiliser les équipements corrects, les bonnes procédures et suffisamment de personnes pour soulever et déplacer les bouteilles.
- Lire et suivre les instructions sur les bouteilles de gaz comprimé, l'équipement connexe et le dépliant P-1 de la CGA (Compressed Gas Association) mentionné dans les principales normes de sécurité.

2-3. Dangers supplémentaires en relation avec l'installation, le fonctionnement et la maintenance



Risque D'INCENDIE OU D'EXPLOSION.

- Ne pas placer l'appareil sur, au-dessus ou à proximité de surfaces inflammables.
- Ne pas installer l'appareil à proximité de produits inflammables.
- Ne pas surcharger l'installation électrique – s'assurer que l'alimentation est correctement dimensionnée et protégée avant de mettre l'appareil en service.

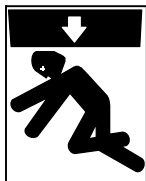

LA CHUTE DE L'APPAREIL peut blesser.

- Utiliser l'anneau de levage uniquement pour soulever l'appareil, NON PAS les chariots, les bouteilles de gaz ou tout autre accessoire.
- Utiliser un équipement de levage de capacité suffisante pour lever l'appareil.
- En utilisant des fourches de levage pour déplacer l'unité, s'assurer que les fourches sont suffisamment longues pour dépasser du côté opposé de l'appareil.

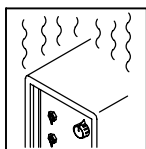

L'EMPLOI EXCESSIF peut SURCHAUFFER L'ÉQUIPEMENT.

- Prévoir une période de refroidissement ; respecter le cycle opératoire nominal.
- Réduire le courant ou le facteur de marche avant de poursuivre le soudage.
- Ne pas obstruer les passages d'air du poste.

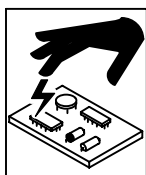

LES CHARGES ÉLECTROSTATIQUES peuvent endommager les circuits imprimés.

- Établir la connexion avec la barrette de terre avant de manipuler des cartes ou des pièces.
- Utiliser des pochettes et des boîtes antistatiques pour stocker, déplacer ou expédier des cartes PC.

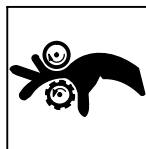

DES ORGANES MOBILES peuvent provoquer des blessures.

- Ne pas s'approcher des organes mobiles.
- Ne pas s'approcher des points de coincement tels que des rouleaux de commande.



LES FILS DE SOUDAGE peuvent provoquer des blessures.

- Ne pas appuyer sur la gâchette avant d'en avoir reçu l'instruction.
- Ne pas diriger le pistolet vers soi, d'autres personnes ou toute pièce mécanique en engageant le fil de soudage.



DES ORGANES MOBILES peuvent provoquer des blessures.

- S'abstenir de toucher des organes mobiles tels que des ventilateurs.
- Maintenir fermés et verrouillés les portes, panneaux, recouvrements et dispositifs de protection.
- Seules des personnes qualifiées sont autorisées à enlever les portes, panneaux, recouvrements ou dispositifs de protection pour l'entretien.
- Remettre les portes, panneaux, recouvrements ou dispositifs de protection quand l'entretien est terminé et avant de rebrancher l'alimentation électrique.

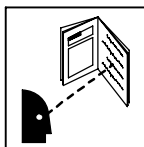

LIRE LES INSTRUCTIONS.

- Lire le manuel d'utilisation avant d'utiliser ou d'intervenir sur l'appareil.
- Utiliser uniquement des pièces de rechange Miller/Hobart.

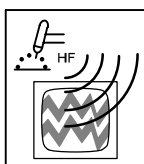

LE RAYONNEMENT HAUTE FRÉQUENCE (HF) risque de provoquer des interférences.

- Le rayonnement haute fréquence (HF) peut provoquer des interférences avec les équipements de radio-navigation et de communication, les services de sécurité et les ordinateurs.
- Demander seulement à des personnes qualifiées familiarisées avec des équipements électroniques de faire fonctionner l'installation.
- L'utilisateur est tenu de faire corriger rapidement par un électricien qualifié les interférences résultant de l'installation.
- Si le FCC signale des interférences, arrêter immédiatement l'appareil.
- Effectuer régulièrement le contrôle et l'entretien de l'installation.
- Maintenir soigneusement fermés les portes et les panneaux des sources de haute fréquence, maintenir les éclateurs à une distance correcte et utiliser une terre et un blindage pour réduire les interférences éventuelles.

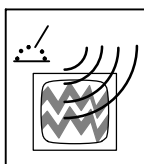

LE SOUDAGE À L'ARC risque de provoquer des interférences.

- L'énergie électromagnétique peut gêner le fonctionnement d'appareils électroniques comme des ordinateurs et des robots.
- Veiller à ce que tout l'équipement de la zone de soudage soit compatible électromagnétiquement.
- Pour réduire la possibilité d'interférence, maintenir les câbles de soudage aussi courts que possible, les grouper, et les poser aussi bas que possible (ex. par terre).
- Veiller à souder à une distance de 100 mètres de tout équipement électronique sensible.
- Veiller à ce que ce poste de soudage soit posé et mis à la terre conformément à ce mode d'emploi.
- En cas d'interférences après avoir pris les mesures précédentes, il incombe à l'utilisateur de prendre des mesures supplémentaires telles que le déplacement du poste, l'utilisation de câbles blindés, l'utilisation de filtres de ligne ou la pose de protecteurs dans la zone de travail.

2-4. Proposition californienne 65 Avertissements

▲ Les équipements de soudage et de coupage produisent des fumées et des gaz qui contiennent des produits chimiques dont l'État de Californie reconnaît qu'ils provoquent des malformations congénitales et, dans certains cas, des cancers. (Code de santé et de sécurité de Californie, chapitre 25249.5 et suivants)

▲ Les batteries, les bornes et autres accessoires contiennent du plomb et des composés à base de plomb, produits chimiques dont l'État de Californie reconnaît qu'ils provoquent des cancers et des malformations congénitales ou autres problèmes de procréation. Se laver les mains après manipulation.

Pour les moteurs à essence :

▲ Les gaz d'échappement des moteurs contiennent des produits chimiques dont l'État de Californie reconnaît qu'ils provoquent des cancers et des malformations congénitales ou autres problèmes de procréation.

Pour les moteurs diesel :

▲ Les gaz d'échappement des moteurs diesel et certains de leurs composants sont reconnus par l'État de Californie comme provoquant des cancers et des malformations congénitales ou autres problèmes de procréation.

2-5. Principales normes de sécurité

Safety in Welding, Cutting, and Allied Processes, ANSI Standard Z49.1, de Global Engineering Documents (téléphone : 1-877-413-5184, site Internet : www.global.ihs.com).

Recommended Safe Practices for the Preparation for Welding and Cutting of Containers and Piping, American Welding Society Standard AWS F4.1 de Global Engineering Documents (téléphone : 1-877-413-5184, site Internet : www.global.ihs.com).

National Electrical Code, NFPA Standard 70, de National Fire Protection Association, P.O. Box 9101, 1 Battery March Park, Quincy, MA 02269-9101 (téléphone : 617-770-3000, site Internet : www.nfpa.org).

Safe Handling of Compressed Gases in Cylinders, CGA Pamphlet P-1, de Compressed Gas Association, 1735 Jefferson Davis Highway, Suite 1004, Arlington, VA 22202-4102 (téléphone : 703-412-0900, site Internet : www.cganet.com).

Code for Safety in Welding and Cutting, CSA Standard W117.2, de Canadian Standards Association, Standards Sales, 178 Rexdale

Boulevard, Rexdale, Ontario, Canada M9W 1R3 (téléphone : 800-463-6727 ou à Toronto 416-747-4044, site Internet : www.csa-international.org).

Practice For Occupational And Educational Eye And Face Protection, ANSI Standard Z87.1, de American National Standards Institute, 11 West 42nd Street, New York, NY 10036-8002 (téléphone : 212-642-4900, site Internet : www.ansi.org).

Standard for Fire Prevention During Welding, Cutting, and Other Hot Work, NFPA Standard 51B, de National Fire Protection Association, P.O. Box 9101, 1 Battery March Park, Quincy, MA 02269-9101 (téléphone : 617-770-3000, site Internet : www.nfpa.org).

OSHA, Occupational Safety and Health Standards for General Industry, Title 29, Code of Federal Regulations (CFR), Part 1910, Subpart Q, and Part 1926, Subpart J, de U.S. Government Printing Office, Superintendent of Documents, P.O. Box 371954, Pittsburgh, PA 15250 (il y a 10 bureaux régionaux—le téléphone de la région 5, Chicago, est 312-353-2220, site Internet : www.osha.gov).

2-6. Information EMF

Considérations sur le soudage et les effets de basse fréquence et des champs magnétiques et électriques.

Le courant de soudage, pendant son passage dans les câbles de soudage, causera des champs électromagnétiques. Il y a eu et il y a encore un certain souci à propos de tels champs. Cependant, après avoir examiné plus de 500 études qui ont été faites pendant une période de recherche de 17 ans, un comité spécial ruban bleu du National Research Council a conclu : « L'accumulation de preuves, suivant le jugement du comité, n'a pas démontré que l'exposition aux champs magnétiques et champs électriques à haute fréquence représente un risque à la santé humaine ». Toutefois, des études sont toujours en cours et les preuves continuent à être examinées. En attendant que les conclusions finales de la recherche soient établies, il vous serait souhaitable de réduire votre exposition aux champs électromagnétiques pendant le soudage ou le coupage.

Pour réduire les champs magnétiques sur le poste de travail, appliquer les procédures suivantes :

1. Maintenir les câbles ensemble en les tordant ou en les enveloppant.
2. Disposer les câbles d'un côté et à distance de l'opérateur.
3. Ne pas courber pas et ne pas entourer pas les câbles autour de votre corps.
4. Garder le poste de soudage et les câbles le plus loin possible de vous.
5. Connecter la pince sur la pièce aussi près que possible de la soudeuse.

En ce qui concerne les stimulateurs cardiaques

Les porteurs de stimulateur cardiaque doivent consulter leur médecin avant de souder ou d'approcher des opérations de soudage. Si le médecin approuve, il est recommandé de suivre les procédures précédentes.

SECTION 3 – INSTALLATION



3-1. Specifications

Rated Output		Max. Open Circuit Voltage	60 Hz	Amps Input at Rated Output					
				200 V	230 V	460 V	575V	KVA	KW
300 A at 32 VDC, 60% Duty Cycle	350 A at 32 VDC, 40% Duty Cycle	90	Single-Phase	69 (1.7*)	61 (1.5*)	30 (0.75*)	24 (0.5*)	13.1	11.2
			Three-Phase	34 (1.7*)	30 (1.5*)	15 (0.75*)	12 (0.5*)	11.6	11.5

* While idling

Wire Type and Diameter			Wire Feed Speed	Dimensions	Net Weight
Solid Steel	Stainless Steel	Aluminum	50-700 IPM (1.3-17.8 m/min)	H: 34 in (864 mm) W: 19 in (483 mm) D: 41 in (1041 mm)	181 lb (82 kg)
.023 – .045 in (0.8 – 1.1 mm)	.030 – .045 in (0.8 – 1.1 mm)	.035 – .047 in (0.9 – 1.2 mm)			
Operating Temperature Range: -20C to +40C			Storage Temperature Range: -30C to + 50C		

3-2. Duty Cycle And Overheating

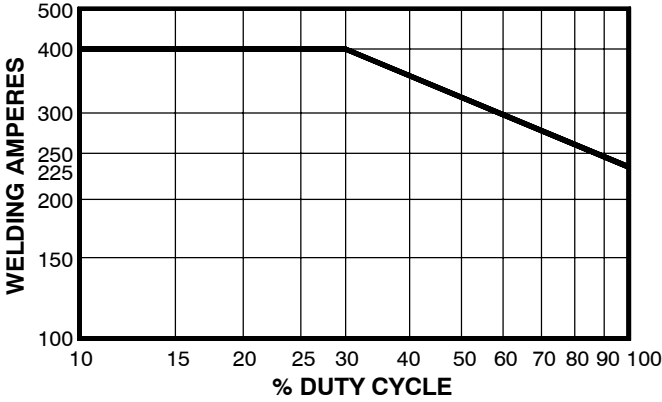

WELDING AMPERES

% DUTY CYCLE

Duty Cycle is percentage of 10 minutes that unit can weld at rated load without overheating.

If unit overheats, thermistors open, output stops, and cooling fan runs. Wait fifteen minutes for unit to cool. Reduce amperage or voltage, or duty cycle before welding.

▲ Exceeding duty cycle can damage unit and void warranty.

60% Duty Cycle At 300 Amperes

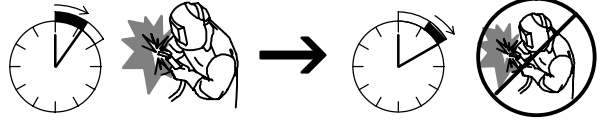

6 Minutes Welding 4 Minutes Resting

40% Duty Cycle At 350 Amperes

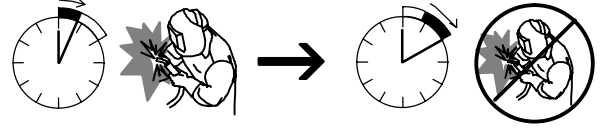

4 Minutes Welding 6 Minutes Resting

Overheating

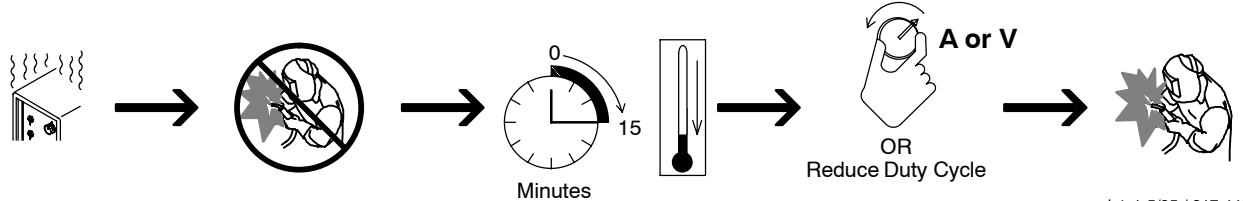

Minutes OR Reduce Duty Cycle

sduty1 5/95 / 217 442-A

3-3. Volt-Ampere Curve

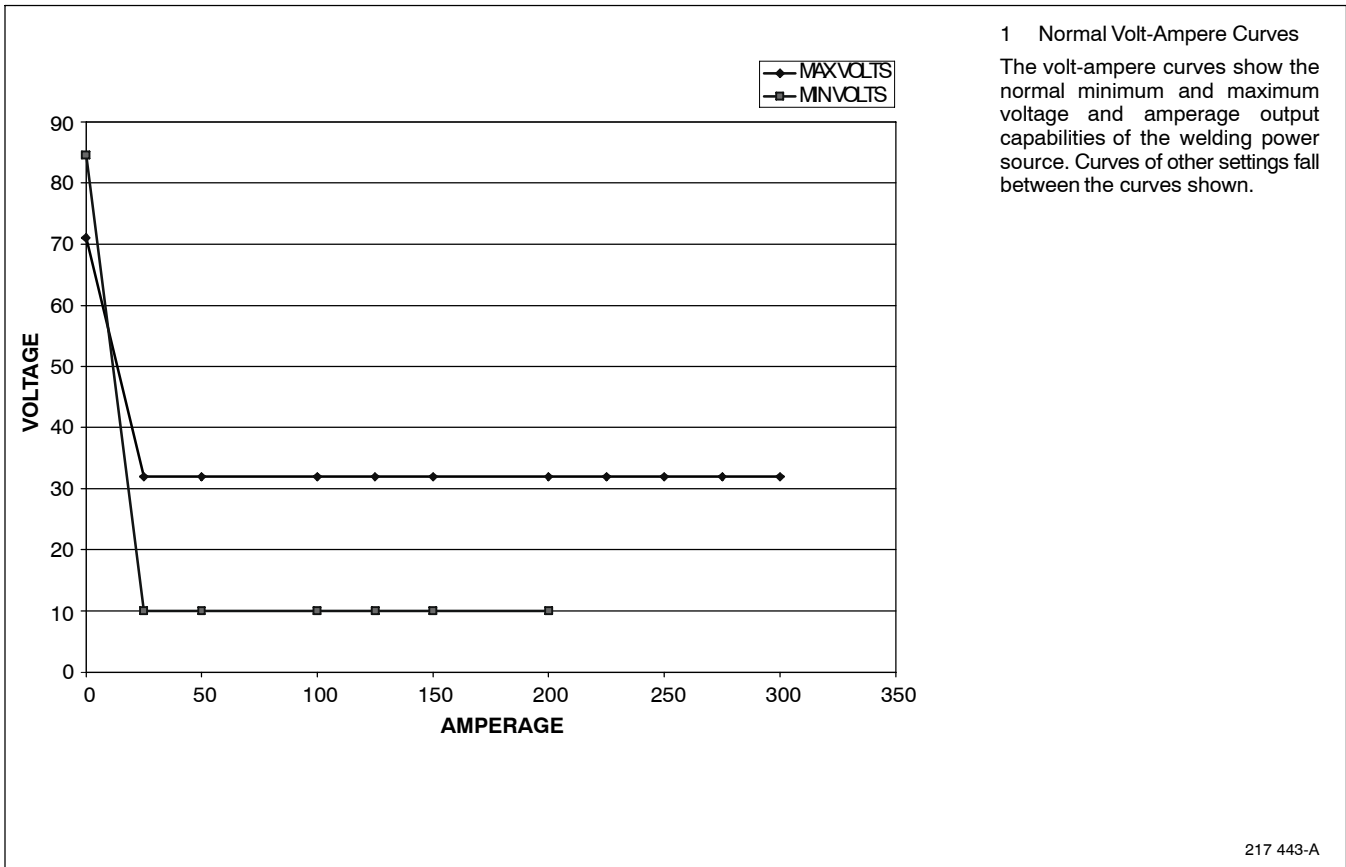

3-4. Connecting To Weld Output Terminals

Tools Needed:
 3/4 in (19 mm)

Do not place anything between weld cable terminal and copper bar.

Correct Installation

Incorrect Installation

▲ **Turn off power before connecting to weld output terminals.**

▲ **Failure to properly connect weld cables may cause excessive heat and start a fire, or damage your machine.**

1 Weld Output Terminal
 2 Supplied Weld Output Terminal Nut
 3 Weld Cable Terminal
 4 Copper Bar

Remove supplied nut from weld output terminal. Slide weld cable terminal onto weld output terminal and secure with nut so that weld cable terminal is tight against copper bar. **Do not place anything between weld cable terminal and copper bar. Make sure that the surfaces of the weld cable terminal and copper bar are clean.**

803 778-A

3-5. Installing Work Clamp

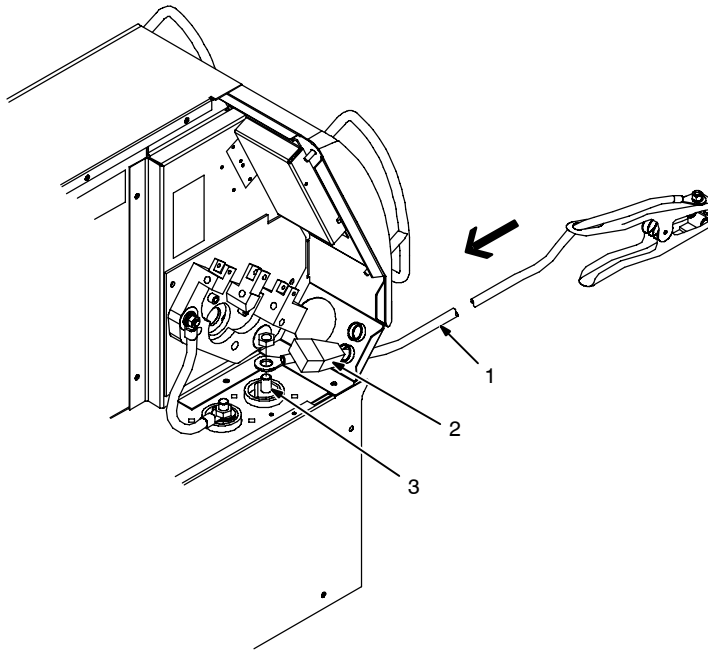

- 1 Work Cable
 - 2 Boot
- Route cable through front panel opening. Slide boot onto work cable.
- 3 Negative (-) Output Terminal
- Connect cable to terminal and cover connection with boot.
Close door.

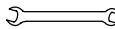
Tools Needed:
 3/4 in

803 540-B

3-6. Installing Welding Gun/Cable Holder

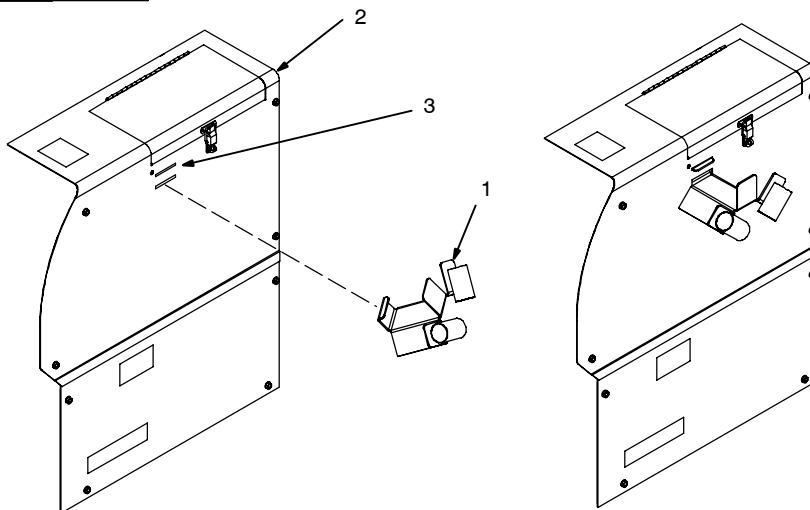

- 1 Welding Gun/Cable Holder
 - 2 Wrapper
 - 3 Slots
- Angle holder to insert hook through bottom slot. Drop holder down so that hook exits top slot.

Ref. 803 545-B / Ref. 803 539-B

3-7. Installing Welding Gun

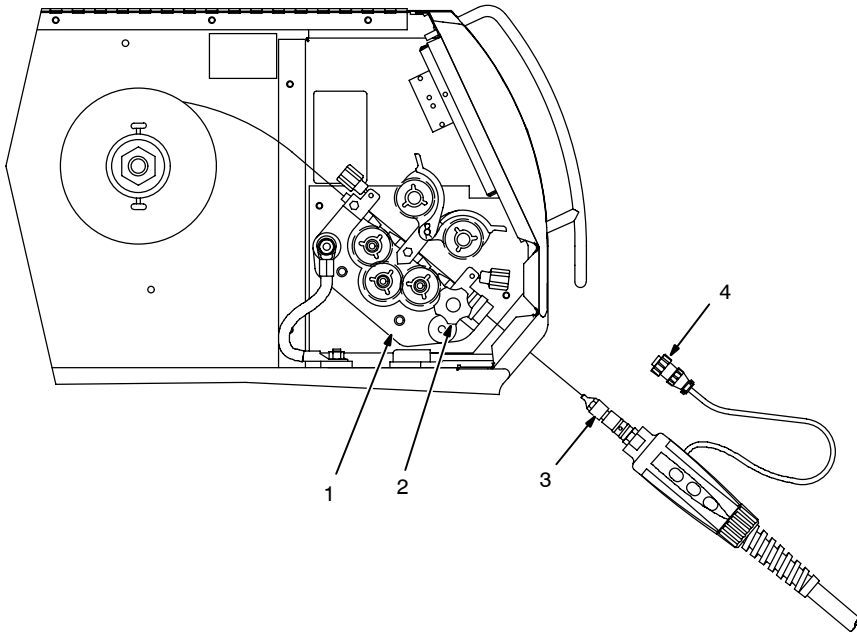

- 1 Drive Assembly
- 2 Gun Securing Knob
- 3 Gun End

Loosen securing knob. Insert gun end through opening until it bottoms against drive assembly (make sure gun end does not touch drive rolls). Tighten knob.

- 4 Gun Trigger Plug

Insert plug into receptacle, and tighten threaded collar.

Close door.

Ref. 803 541-B

3-8. Connecting Spoolmatic® 15A Or 30A Gun

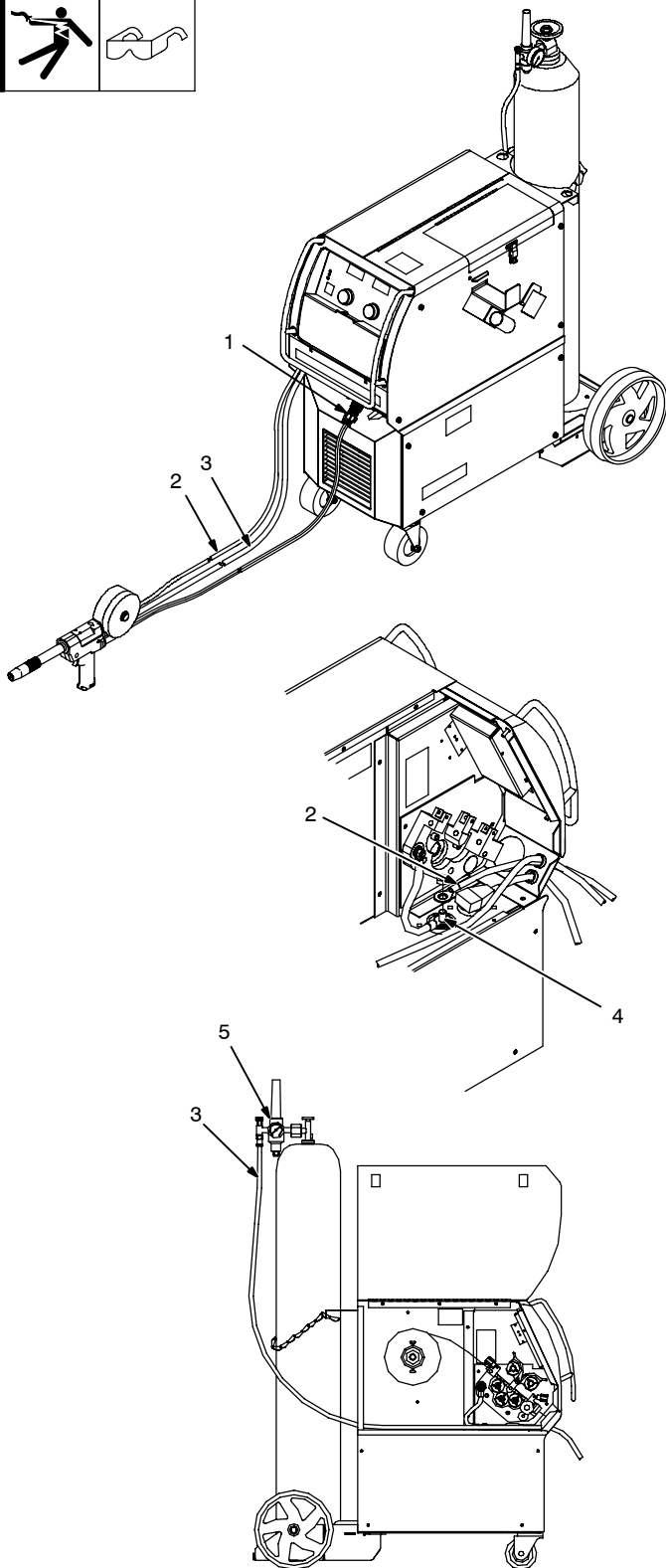

- 1 Gun Trigger Plug
Insert plug into receptacle, and tighten threaded collar.
- 2 Weld Cable
- 3 Shielding Gas Hose
Route weld cable and gas hose through opening in front panel.
- 4 Positive Weld Output Terminal
Connect weld cable to weld output terminal.
- 5 Regulator/Flowmeter
Route shielding gas hose through wire drive compartment, out opening in rear panel, and up to regulator/flowmeter. Connect gas hose to regulator/flowmeter.

Tools Needed:

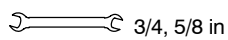

803 568-C

3-9. Connecting XR Edge, XR-A Gun, Or XR-A Python

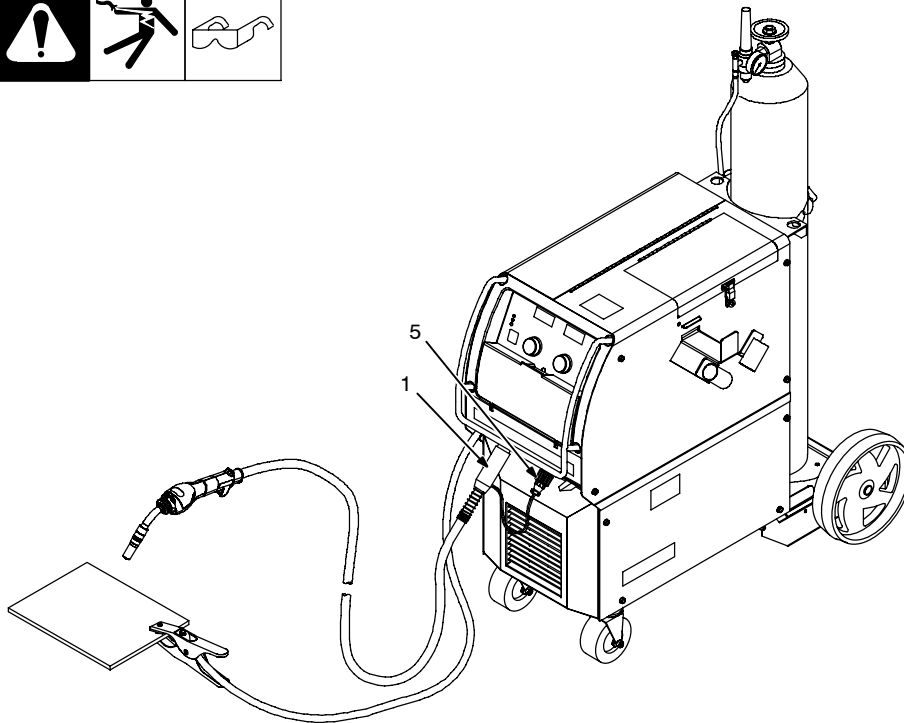

XR Edge guns prior to serial no. LE079101 require an adapter cord (part no. 195 498).

- 1 Gun End
- 2 Gun Liner
- 3 Wire Outlet Guide

Trim excess liner from end of gun so no more than 3/32 in (2.4 mm) of liner extends past wire outlet guide.

- 4 Gun Securing Knob

Loosen securing knob. Insert gun end through opening until it bottoms against drive assembly (make sure gun end does not touch drive rolls). Tighten knob.

Be sure to change drive rolls to the proper size and type.

- 5 Gun Trigger Plug

Insert plug into receptacle, and tighten threaded collar.

Be sure to trim liner to proper extension.

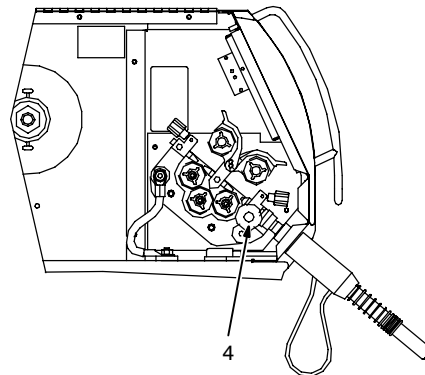
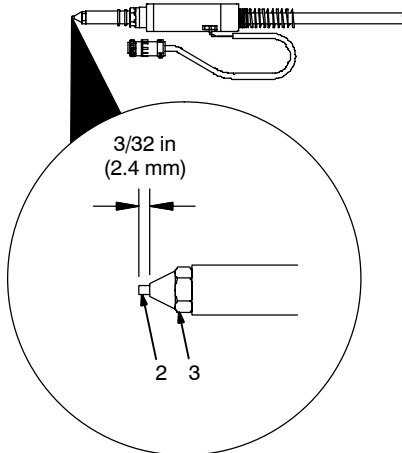

3-10. Setting Gun Polarity For Wire Type



Changing Polarity

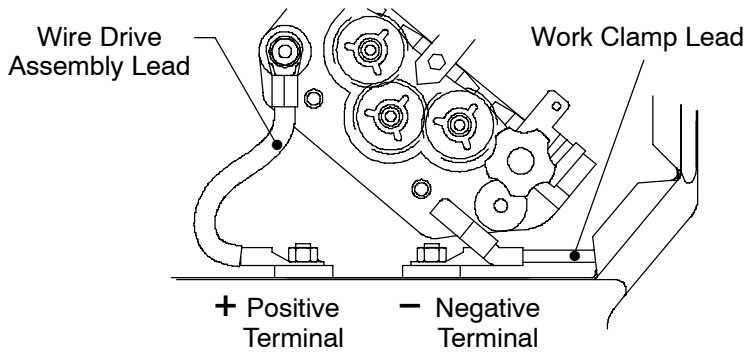

Shown as shipped – **Electrode Positive (DCEP)**: For solid steel, stainless steel, aluminum, or flux core with gas wires (GMAW).

Electrode Negative (DCEN): Reverse lead connections at terminals from that shown above for gasless flux core wires (FCAW). Drive assembly becomes negative.

1 Polarity Changeover Information
Always read and follow manufacture's recommended polarity.

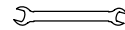
 3/4, 11/16 in

Ref. 803 541-A

3-11. Installing Gas Supply



DO NOT use Argon/Mixed gas regulator/flowmeter with CO₂ shielding gas. See Parts List for optional CO₂ gas regulator/flowmeter.

Regulator/Flowmeter for 350P model shown.

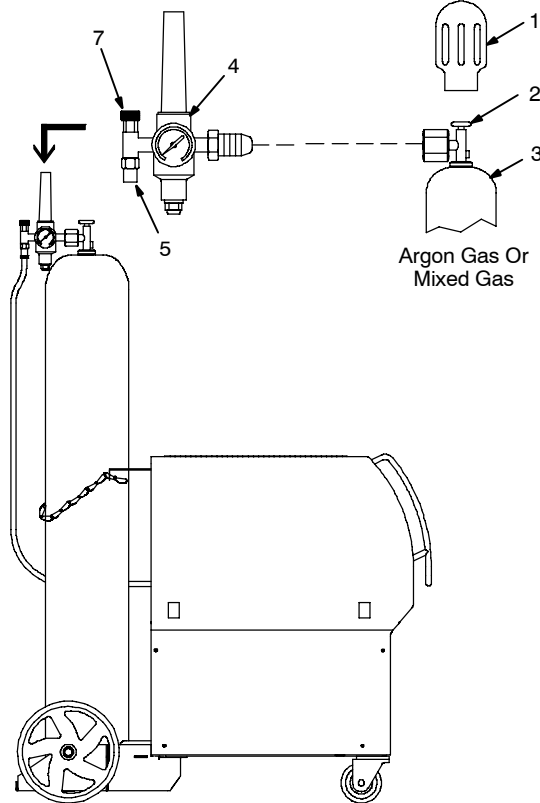

Obtain gas cylinder and chain to running gear, wall, or other stationary support so cylinder cannot fall and break off valve.

- 1 Cap
- 2 Cylinder Valve

Remove cap, stand to side of valve, and open valve slightly. Gas flow blows dust and dirt from valve. Close valve.

- 3 Cylinder
 - 4 Regulator/Flowmeter
- Install so face is vertical.

- 5 Regulator/Flowmeter Gas Hose Connection

- 6 Welding Power Source Gas Hose Connection

Connect supplied gas hose between regulator/flowmeter gas hose connection, and fitting on rear of welding power source.

- 7 Flow Adjust

Typical flow rate is 20 cfh (cubic feet per hour). Check wire manufacturer's recommended flow rate.

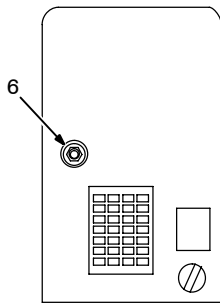

Rear Panel

Tools Needed:

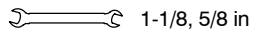

1-1/8, 5/8 in

803 542-A

3-12. Installing Wire Spool and Adjusting Hub Tension

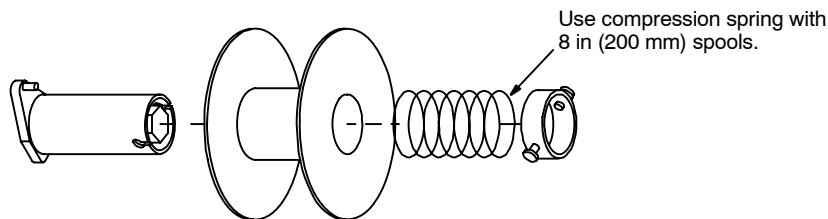

When a slight force is needed to turn spool, tension is set.

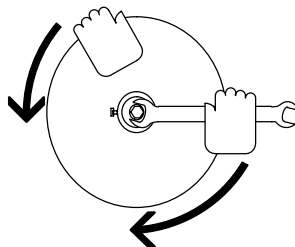

Tools Needed:

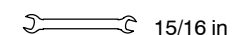

15/16 in

072573-B

3-13. Electrical Service Guide

Input Voltage	60 Hz Single Phase				60 Hz Three Phase			
	200	230	460	575	200	230	460	575
Input Amperes At Rated Output	69	61	30	24	34	30	15	12
Max Recommended Standard Fuse Rating In Amperes Circuit Breaker ¹ , Time-Delay ² Normal Operating ³	80	70	35	25	40	35	15	10
	100	90	40	35	50	45	20	15
Min Input Conductor Size In AWG ⁴	6	8	10	12	10	10	14	14
Max Recommended Input Conductor Length In Feet (Meters)	101 (31)	86 (26)	229 (70)	217 (66)	86 (26)	114 (35)	178 (54)	277 (85)
Min Grounding Conductor Size In AWG ⁴	8	8	10	12	10	10	14	14

Reference: 2005 National Electrical Code (NEC) (including article 630)

1 Choose a circuit breaker with time-current curves comparable to a Time Delay Fuse.

2 "Time-Delay" fuses are UL class "RK5" .

3 "Normal Operating" (general purpose - no intentional delay) fuses are UL class "K5" (up to and including 60 amp), and UL class "H" (65 amp and above).

4 Conductor data in this section specifies conductor size (excluding flexible cord or cable) between the panelboard and the equipment per NEC Table 310.16. If a flexible cord or cable is used, minimum conductor size may increase. See NEC Table 400.5(A) for flexible cord and cable requirements.

▲ Caution: Failure to follow these fuse and circuit breaker recommendations could create an electric shock or fire hazard. These recommendations are for a dedicated branch circuit that applies to the rated output and duty cycle of the welding power source.

▲ Caution: This unit is either a 200/230/460 ac input voltage model or 460/575 ac input voltage model. See rating label on unit and check voltage available at site to be sure it matches the voltage specified on the rating label.

3-14. Selecting Input Voltage (200/230/460 Volt Models Only)



☞ *Be sure to reinstall all four screws securing relinking board in place.*

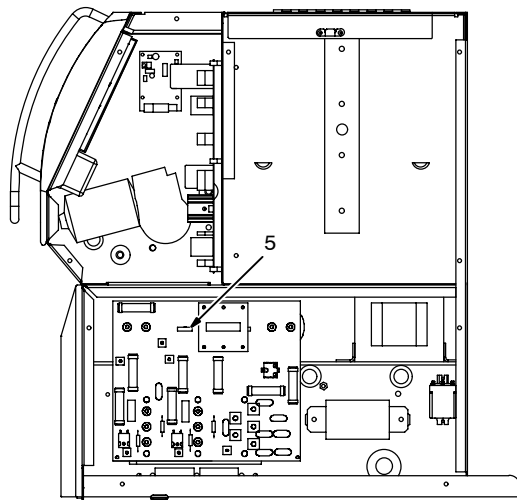
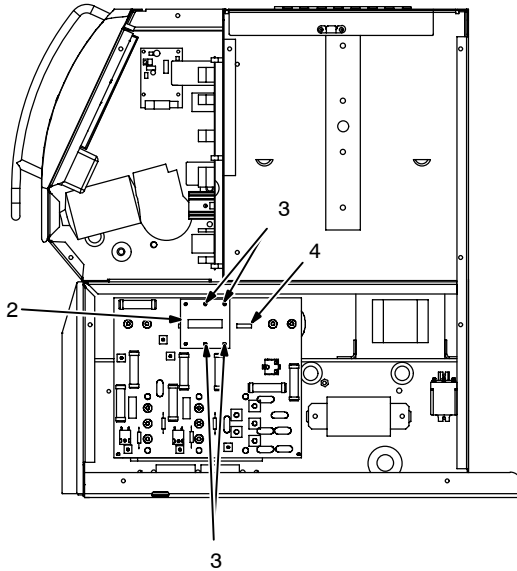
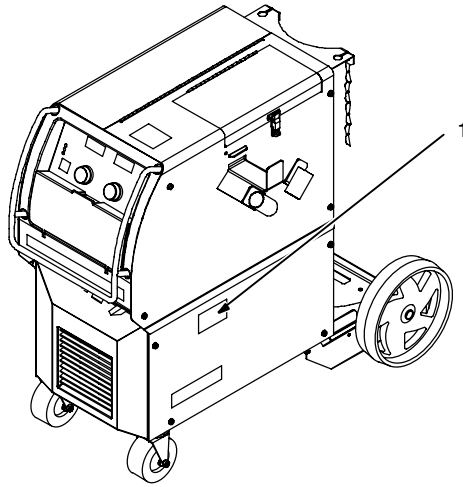

▲ Turn Off welding power source, disconnect input power, and check voltage on input capacitors according to Section 6-3 before proceeding.

☞ *Check input voltage available at site.*

☞ *Incorrect linking can damage unit and void the warranty.*

1 Voltage Selection View Window

Check voltage selected in unit. Changing selection is only necessary if selected value does not match available input voltage.

2 Relinking Board PC6

3 Mounting Screws

4 Receptacle RC23
(Connection For 230 VAC Input Power)

5 Receptacle RC46
(Connection For 460 VAC Input Power)

Move relinking board as needed and connect plug PLG32 (in unit) to RC23 or RC46 according to input power voltage.

Tools Needed:

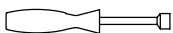

5/16 in

3-15. Selecting A Location And Connecting 3-Phase Input Power

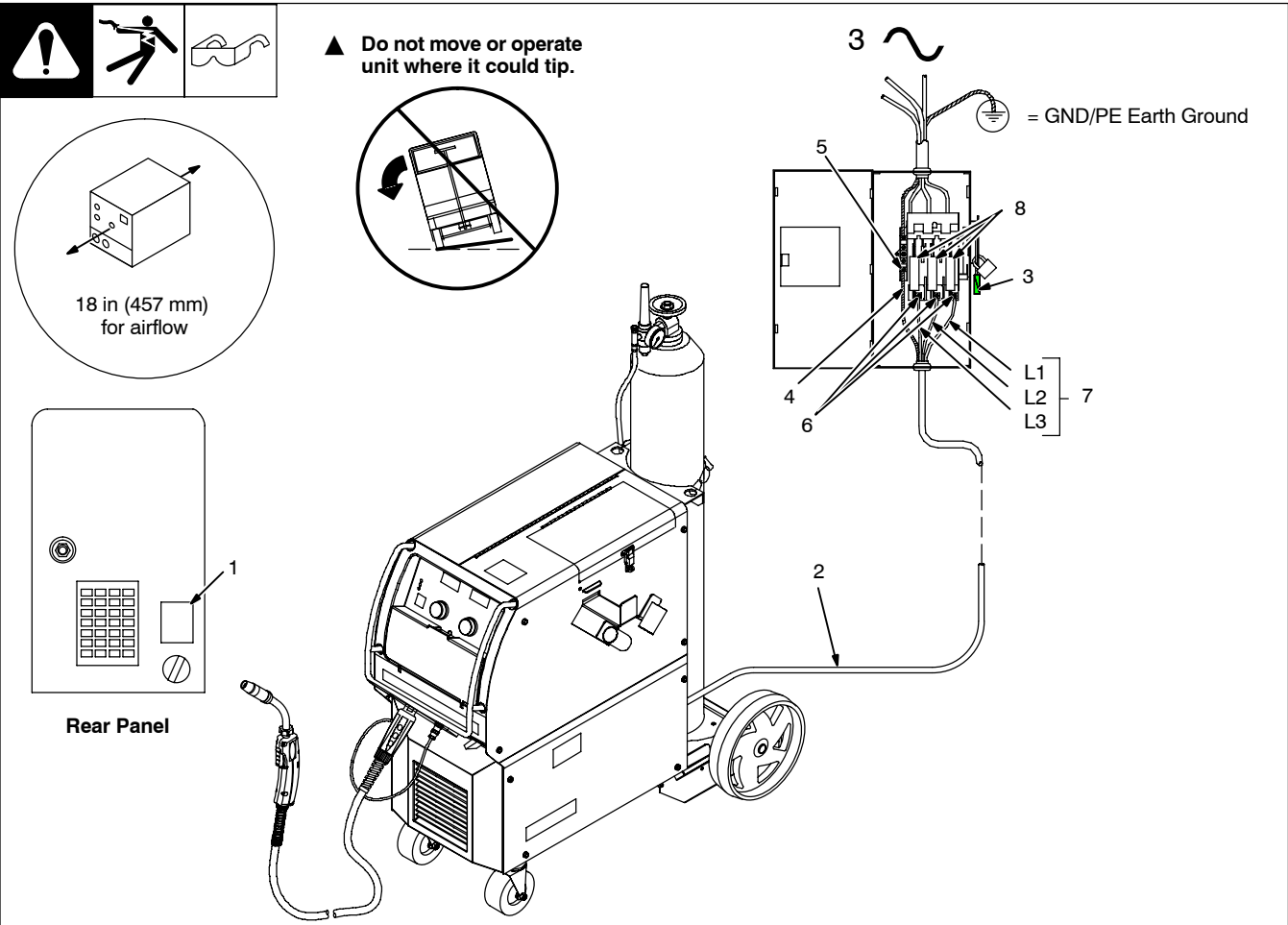

▲ Do not move or operate unit where it could tip.

18 in (457 mm) for airflow

Rear Panel

Tools Needed:



Ref. 803 543-D / 803 766-A

- ▲ Installation must meet all National and Local Codes - have only qualified persons make this installation.
 - ▲ Disconnect and lockout/tagout input power before connecting input conductors from unit.
 - ▲ Always connect green or green/yellow conductor to supply grounding terminal first, and never to a line terminal.
 - ▲ Caution: This unit is either a 200/230/460 ac input voltage model or 460/575 ac input voltage model. See rating label on unit and check voltage available at site to be sure it matches the voltage specified on the rating label.
- | | |
|---|---|
| <ul style="list-style-type: none"> 1 Rating Label 2 Input Power Cord 3 Disconnect Device (switch shown in the OFF position) 4 Green Or Green/Yellow Grounding Conductor 5 Disconnect Device Grounding Terminal 6 Input Conductors (L1, L2 And L3) 7 Disconnect Device Line Terminals | <ul style="list-style-type: none"> 8 Over-Current Protection |
|---|---|
- Connect green or green/yellow grounding conductor to disconnect device grounding terminal first.
- Connect input conductors L1, L2, and L3 to disconnect device line terminals.
- Select type and size of over-current protection using Section 3-13 (fused disconnect switch shown).
- Close and secure door on disconnect device. Remove lockout/tagout device, and place switch in the On position.

3-16. Selection A Location And Connecting 1-Phase Input Power

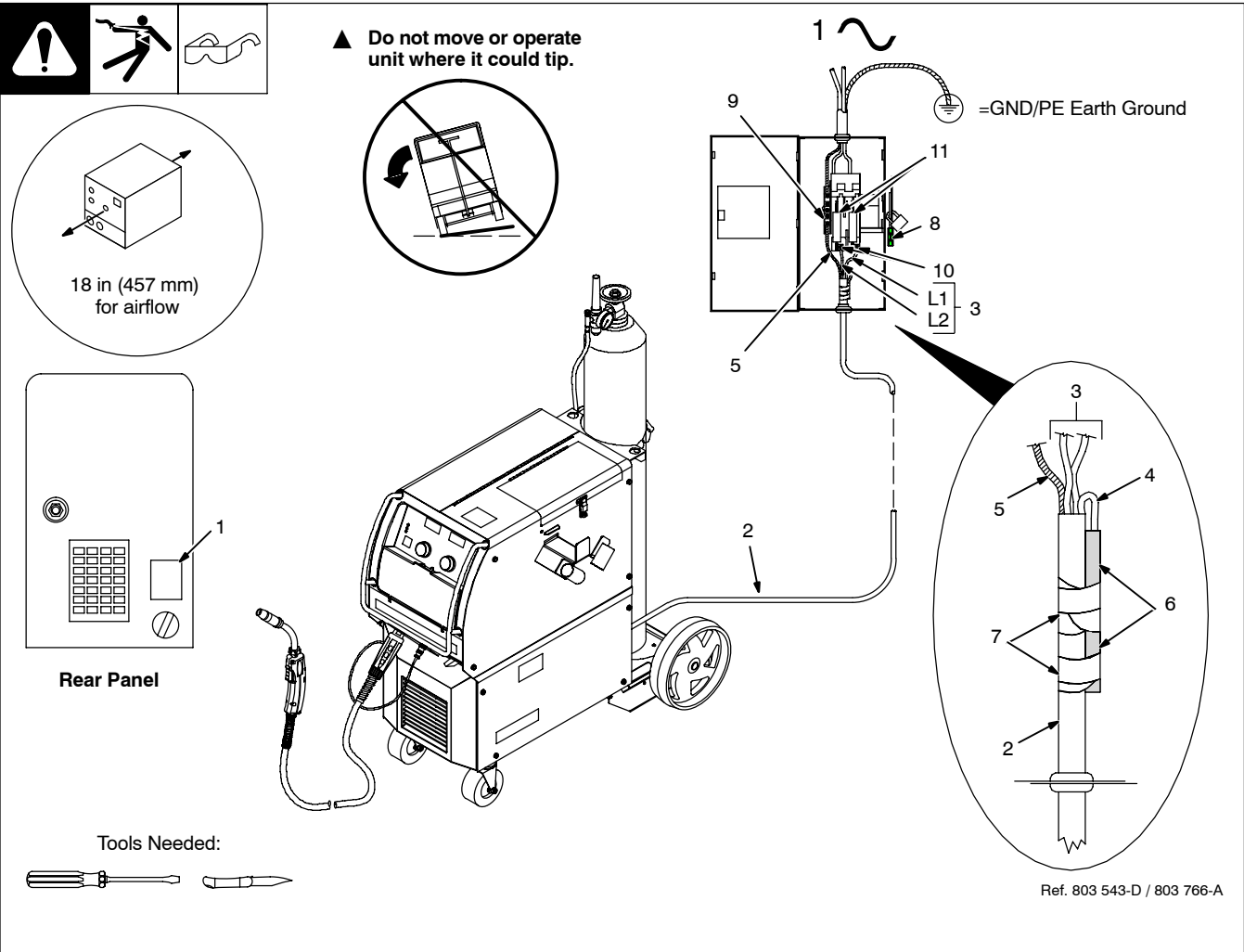

Ref. 803 543-D / 803 766-A

- ▲ **Installation must meet all National and Local Codes - have only qualified persons make this installation.**
- ▲ **Disconnect and lockout/tagout input power before connecting input conductors form unit.**
- ▲ **Always connect green or green/yellow conductor to supply grounding terminal first, and never to a line terminal.**
- ▲ **Caution: This unit is either a 200/230/460 ac input voltage model or 460/575 ac input voltage model. See rating label on unit and check voltage available at site to be sure it matches the voltage specified on the rating label.**

- Three Conductor Power Cord Preparation**
- 1 Rating Label
 - 2 Input Power Cord
 - 3 Black And White Input Conductors (L1 And L2)
 - 4 Red Input Conductor
 - 5 Green Or Green/Yellow Grounding Conductor
 - 6 Insulation Sleeving
 - 7 Electrical Tape
- Insulate and isolate red conductor as shown.
- Disconnect Device Input Power Connections**
- 8 Disconnect Device (switch shown in the OFF position)

- 9 Disconnect Device Grounding Terminal
 - 10 Disconnect Device Line Terminals
- Connect green or green/yellow grounding conductor (see Item 6) to disconnect device grounding terminal first.
- Connect input conductors L1 and L2 to disconnect device line terminals.
- 11 Over-Current Protection
- Select type and size of over-current protection using Section 3-13 (fused disconnect switch shown).
- Close and secure door on disconnect device. Remove lockout/tagout device, and place switch in the On position.

3-17. Threading Welding Wire For MIG Gun



- 1 Wire Spool
 - 2 Welding Wire
 - 3 Inlet Wire Guide
 - 4 Drive Roll
 - 5 Intermediate Wire Guide
 - 6 Outlet Wire Guide
 - 7 Pressure Adjustment Knob
 - 8 Gun Conduit Cable
- Lay gun cable out straight.

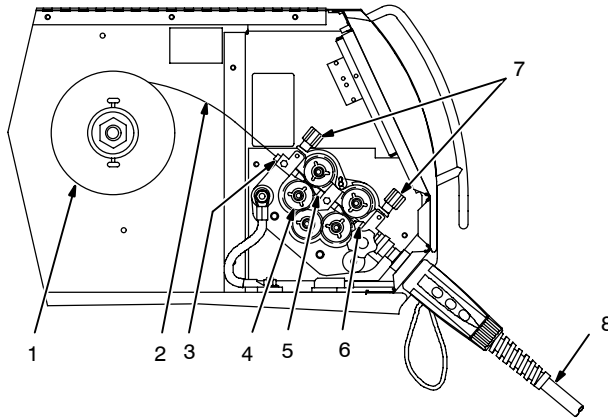

Tools Needed:

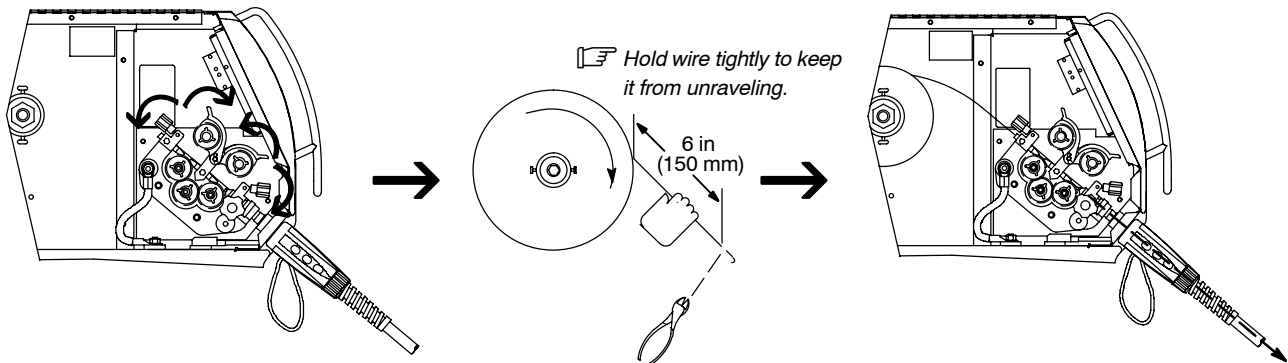
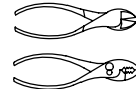

Open pressure assembly.

Pull and hold wire; cut off end.

Push wire thru guides into gun; continue to hold wire.

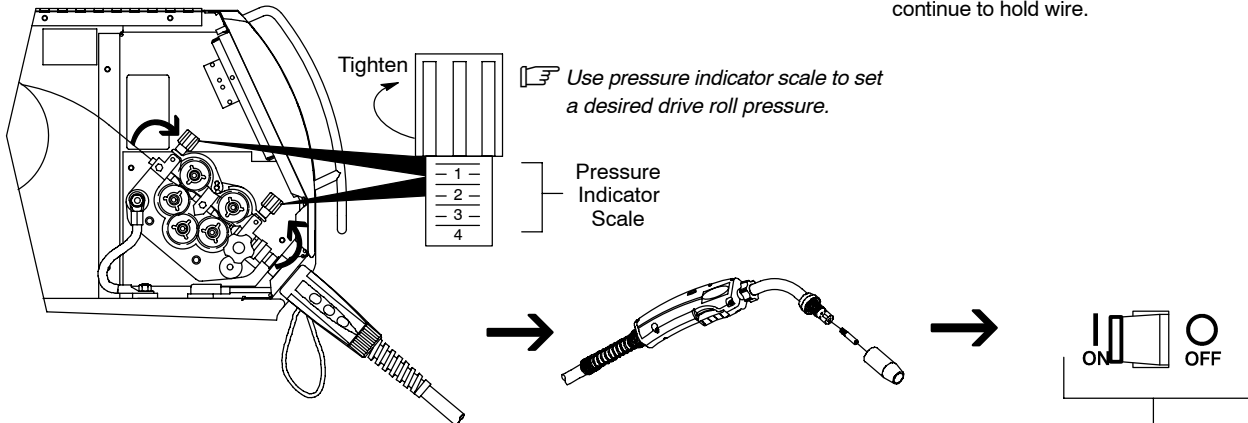

Close and tighten pressure assembly, and let go of wire.

Remove gun nozzle and contact tip.

Turn On.

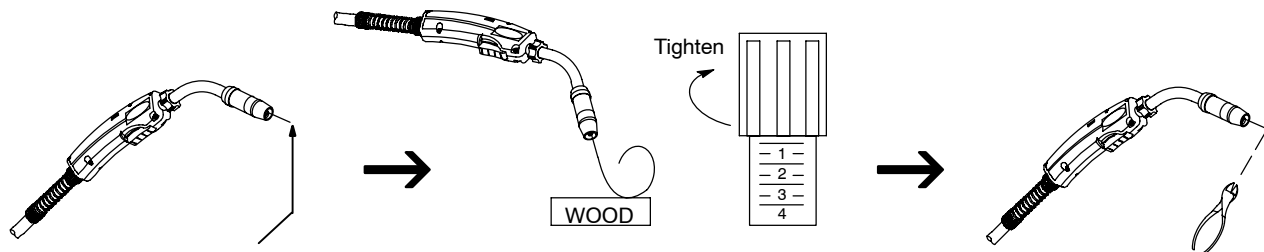

Press gun trigger until wire comes out of gun. Reinstall contact tip and nozzle

Feed wire to check drive roll pressure. Tighten knob enough to prevent slipping.

Cut off wire. Close and latch door.

3-18. Threading Welding Wire For XR Edge, XR-A Gun, Or XR-A Python



- 1 Wire Spool
 - 2 Welding Wire
 - 3 Inlet Wire Guide
 - 4 Drive Roll
 - 5 Intermediate Wire Guide
 - 6 Outlet Wire Guide
 - 7 Pressure Adjustment Knob
 - 8 Gun Conduit Cable
- Lay gun cable out straight.

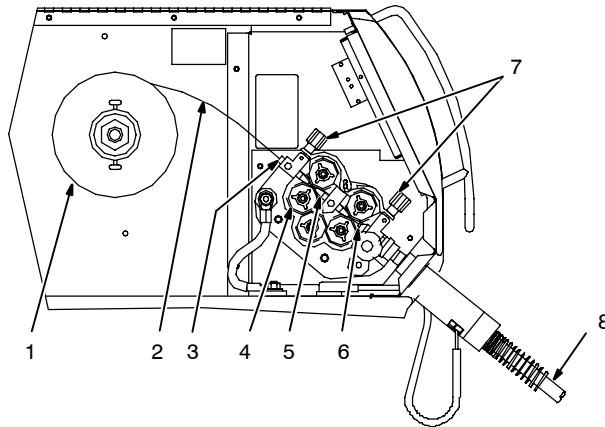

Tools Needed:

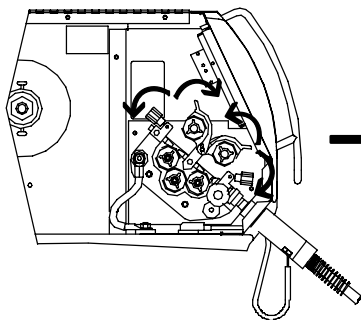
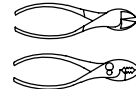

Open pressure assembly.

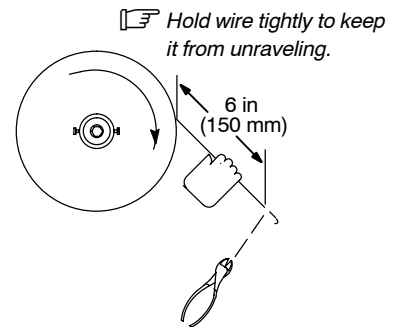

Pull and hold wire; cut off end.

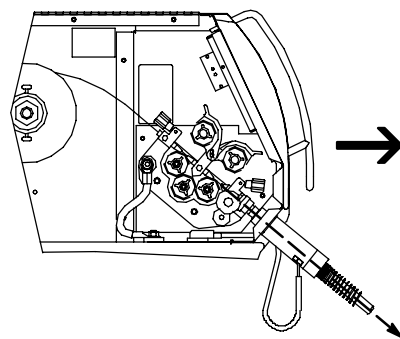

Push wire thru guides into gun; continue to hold wire.

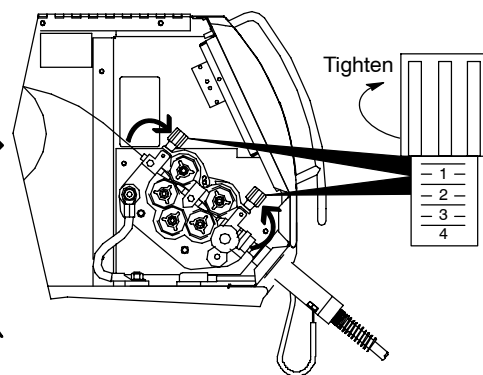

Close and tighten pressure assembly, and let go of wire.



Use pressure indicator scale to set front drive roll pressure to 1 and rear drive roll pressure to less than 1.

➔ See Section 3-19 for threading welding wire through XR guns.

3-19. Threading Welding Wire Through XR Guns



▲ **Welding wire is electrically live when gun trigger is used to jog wire.**

For XR-A Edge Gun:

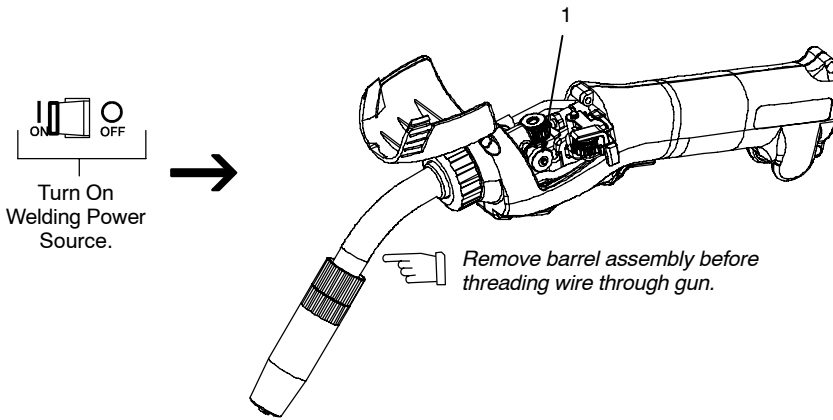

☞ Refer to Section 3-18 for instructions on feeding wire through welding power source.

1 Pressure Roll Assembly

Lay gun cable out straight.

Open top cover, and open pressure roll assembly. If not already done, remove gun barrel assembly.

Press gun trigger until about 4 in (102 mm) of wire is sticking out front of gun. Insert wire into barrel liner and tighten barrel assembly. Install correct size contact tube and install collet nut.

Close top cover on gun. Press trigger switch until about 6 in (152 mm) of wire is sticking out end of contact tip. Cut off wire. Close and latch door.

☞ XR Edge gun drive roll pressure should be set at minimum.

For XR-A Pistol Gun:

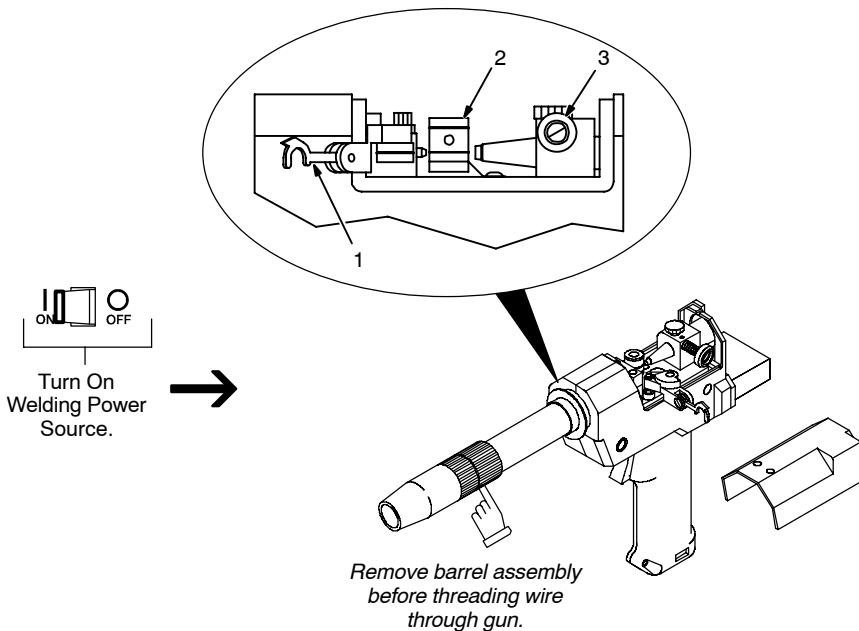

1 Pressure Roll Assembly

2 Drive Roll

3 Thumbscrew

Lay gun cable out straight. Open top cover, and lift pressure arm and open pressure roll assembly. If not already done, remove gun barrel assembly.

Manually thread wire along drive roll groove. Close pressure roll assembly. Press gun trigger until about 4 in (102 mm) of wire is sticking out front of gun. Insert wire into barrel liner and tighten barrel assembly. Install correct size contact tube and install collet nut. Reinstall gun cover.

4 Pressure Adjustment Knob

See final pressure adjustment at bottom of page.

For XR-A Pistol Gun:

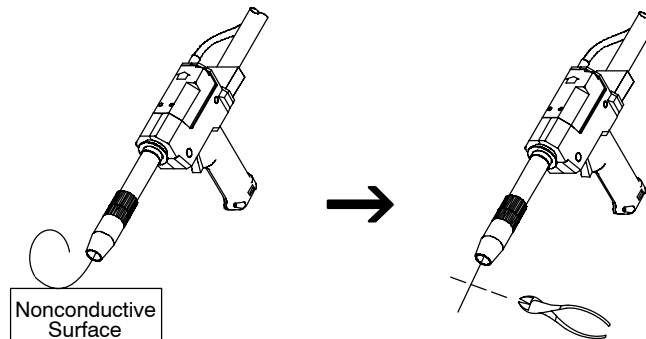

Feed wire to check drive roll pressure. Tighten knob enough to prevent slipping.

Cut off wire. Close and latch door.

▲ **Turn welding power source Off.**

Tools Needed:



☞ Do not exceed midrange setting.

SECTION 4 – OPERATION

4-1. Controls

10 11

1 2 **PULSE
MIG**

3 4 **PROCESS**

5 **WIRE**

6 **TIMERS**

6 **SETUP**

VOLTS **ARC LENGTH** **SETUP** **WIRE SPEED** **AMPS** **SETUP**

8 9

7 **ARC CONTROL**

12

Ref. 213 935-A

<p>1 Pulse Indicator Light</p> <p> Pulse only lights if unit has the pulse MIG module and is programmed for pulse MIG.</p> <p>2 MIG Indicator Lights</p> <p>Pulse (1) and MIG (2) illuminate to Indicate weld mode of unit.</p> <p>3 Process Light</p> <p>PROCESS illuminates when unit is in Process select menu.</p> <p>4 Wire Light</p> <p>WIRE illuminates when unit is in Pulse MIG program select menu.</p> <p>5 Timers Light</p> <p>TIMERS illuminates when unit is in Timers menu.</p> <p>6 Setup Button</p>	<p>7 Arc Control Button</p> <p>Use button to select either inductance control in MIG welding mode or Sharp Arc in Pulse MIG welding mode.</p> <p>8 Left Knob</p> <p>Use knob to adjust volts in MIG welding mode or change parameter values in Setup.</p> <p>9 Right Knob</p> <p>Use knob to adjust wire speed in MIG welding mode or change parameter values in Setup.</p> <p>10 Left Display</p> <p>11 Right Display</p>	<p>12 Weld Functions/Setup Indicator Lights</p> <p>VOLTS illuminates in MIG welding mode indicating volts in left display can be adjusted. Also, VOLTS lights to indicate left display is showing actual voltage during welding and for 5 seconds after the arc is extinguished.</p> <p>ARC LENGTH illuminates in Pulse MIG welding mode indicating Arc Length can be adjusted.</p> <p>SETUP illuminates when a parameter on the corresponding display above the light can be adjusted.</p> <p>WIRE SPEED illuminates in either Pulse MIG or MIG welding mode indicating wire speed can be adjusted.</p> <p>AMPS illuminates indicating welding amps appears in the display, instead of wire speed, during welding and for 5 seconds after the arc is extinguished.</p>
--	--	---

NOTE

The first time the welding power source is energized it starts in MIG welding mode. Each time after the initial startup, when the unit is turned off, whatever mode and parameter settings were last set will remain as the current settings the next time the unit is energized.

4-2. MIG Mode

In MIG mode, VOLTS is lit under left display and WIRE SPEED is lit under right display. Left knob is used to adjust welding voltage within a range of 14-32 volts, and right knob is used to adjust wire feed speed within a range of 25-700 IPM. Refer to weld chart in front compartment for proper parameter settings according to wire type, shielding gas, and material type and thickness.

4-3. Jog Mode

If gun trigger is pressed and held for more than 3 seconds without striking an arc, unit will automatically shut off weld power. For MIG guns, shielding gas will shut off after 1 minute, and for spool guns, shielding gas will continue to flow because gas valve is located inside spool gun. For MIG guns, wire will feed for up to 2 minutes while trigger is pressed, then wire drive system in unit will automatically shut off. For spool guns, wire will feed for up to 30 seconds before shutting off. If gun trigger is pressed for 3 seconds without striking an arc the displays will show JOG MODE.

4-4. Weld Status

When trigger is released on a MIG gun, spool gun, or push-pull gun, the last actual amperage and voltage will be shown on the displays for 5 seconds. The VOLTS and AMPS indicator lights will illuminate under the displays and each value will appear in the corresponding display.

If a programmed value requires adjustment after the arc is extinguished and during the 5 seconds display of actual values, turning either knob will cause actual values in the displays to be replaced by programmed values for adjustment purposes.

NOTE



The 5 second delay after the arc is extinguished for displaying actual weld values can be turned on or off in the Timer menu DISP selection (see Section 5-3).

4-5. MIG Gun-On-Demand

The guns that can be used with this unit are MIG guns, spool guns, and push-pull guns. To switch from one gun to another, momentarily press the trigger on the desired unused gun to make it the active gun. Once the trigger is pressed, the unit will recall stored data and both displays will show the last programmed values for that particular gun. If the unit is powered down and back on again, the gun last used will become the current active gun.

4-6. Pulse MIG Mode Voltage Adjustment

In Pulse MIG mode there is no manual voltage adjustment; instead, voltage is synergically aligned with the proper wire feed speed. Arc Length adjustment is used to adjust actual arc length which automatically adjusts the voltage. See weld chart in front compartment for proper wire feed speed adjustment according to wire size and type.

4-7. Pulse MIG Gun-On-Demand

The spool gun functions slightly different in Pulse MIG mode. To switch from one gun to another, momentarily press the trigger on the desired unused gun to make it the active gun. Once the trigger is pressed, the unit will recall stored data and both displays will show the last programmed values for that particular gun. For a spool gun, the wire speed is taken from the position of the gun potentiometer. This wire speed value is automatically adjusted if the potentiometer is moved since the last time the gun was active. If the unit is powered down and back on again, the gun last used will become the current active gun.

4-8. Tip Saver

If gun contact tip is directly shorted to the workpiece while gun trigger is pressed, the welding arc automatically shuts off after 1 second to prevent wire burnback in the contact tip.

4-9. Weld Parameters For MIG Mode

MIG CHART		MIG CHART										
Material	Gas	Wire	1/2" (12.7mm)	3/8" (9.5mm)	1/4" (6.4mm)	3/16" (4.8mm)	1/8" (3.2mm)	14ga (2.0mm)	16ga (1.6mm)	18ga (1.2mm)	20ga (0.9mm)	22ga (0.8mm)
Steel	100% Co ₂	.035	-	23.0/325	21.5/280	20.5/240	20.0/210	19.0/175	18.5/160	18.0/115	17.0/90	16.5/80
Inductance = 20-40		.045	-	23.0/220	21.5/200	20.5/175	20.0/150	19.0/110	18.5/105	-	-	-
Steel	75% Argon 25% Co ₂	.035	29.3/530	28.5/485	19.5/330	18.5/275	18.0/260	16.5/200	16.0/155	15.5/135	15.0/100	14.5/95
Inductance = 20-40		.045	USE	SPRAY	19.0/220	18.0/200	17.5/170	16.2/150	16.0/130	15.5/100	-	-
Stainless Steel	90% Helium 7.5% Argon 2.5% Co ₂	.035	-	25.0/450	22.5/440	21.5/375	21.0/325	20.0/275	18.0/235	18.5/200	17.5/150	-
Inductance = 60-80		.045	-	-	24.0/400	23.0/300	20.5/250	20.0/235	19.5/175	19.0/160	-	-
Metal Core	90% Argon 10% Co ₂	.045	29.0/475	27.0/425	26.0/400	24.5/350	23.5/300	-	-	-	-	-
Inductance = 30												
Aluminum	100% Argon	.035 4043	-	23.5/700	23.0/530	21.5/450	19.2/380	18.2/300	Reference			
		3/64 4043	24.0/475	23.5/435	23.0/375	21.5/305	19.5/250	Volts/Wirefeed				
		.035 5356	-	23.5/800	23.0/660	21.0/520	19.0/450	23.5 /220				
Inductance = 30		3/64 5356	24.0/535	23.5/500	22.5/465	21.0/375	19.0/340					

4-10. Weld Parameters For Pulse Mode

WELD CHARTS												
<i>All chart parameters are based on the following defaults: arc length - 50, Sharparc® - 25.</i>												
Material	Gas	Wire	1/2" (12.7mm)	3/8" (9.5mm)	1/4" (6.4mm)	3/16" (4.8mm)	1/8" (3.2mm)	14ga (2.0mm)	16ga (1.6mm)	18ga (1.2mm)	19ga (1.0mm)	22ga (0.8mm)
Steel	90% Argon	.035	650	550	400	300	250	200	150	85	—	—
	10% Co 2	.045	500	450	300	200	150	125	100	75	—	—
Stainless Steel	Ar/He/CO2	.035	600	500	400	300	200	175	150	100	—	—
	Tri-Mix	.045	450	350	200	150	125	100	75	50	—	—
Metal Core	90% Argon	.045	475	400	325	250	200	150	125	115	—	—
	10% Co 2											
Aluminum	100% Argon	.035 4043	750	650	550	450	310	210	185	150	130	—
	3/64 4043		450	390	325	260	200	140	110	90	75	—
	.035 5356		—	—	720	640	450	310	245	200	150	—
	3/64 5356		—	550	405	350	290	190	165	115	—	—



PULSE CHART



PULSE CHART



SECTION 5 – PROGRAMMING

5-1. MIG Welding Mode

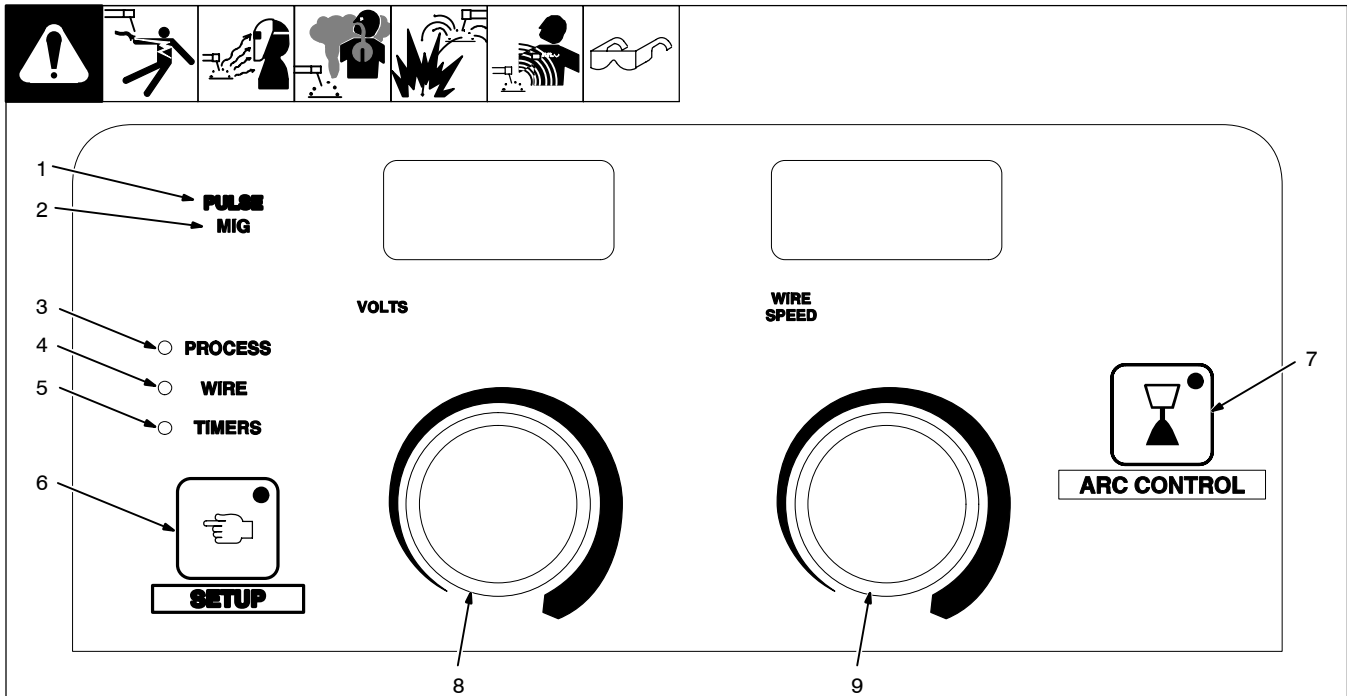

Ref. 213 935-A

When the **MIG** light (2) is illuminated, the unit is in MIG Welding mode.

SETUP

To enter **MIG** welding mode, depress the **SETUP** (6) button once to go to **GUN** selection. Rotate the right knob (9) to select the gun being used. Select **MIG** for standard MIG gun, or select **XR-R**, **EDGE**, **PYTH** for push pull guns, or **SPL** for spoolgun.

Depress **SETUP** (6) a second time to illuminate the **PROCESS** (3) light. Rotate right knob (9) until **MIG** is displayed (for MIG only units **NOT USED** will be displayed).

Depress **SETUP** (6) button again to illuminate the **WIRE** (4) light. This menu is not used in MIG Welding mode.

Depress **SETUP** (6) button again to illuminate **TIMERS** (5) light. For description of the **TIMERS**, refer to **TIMERS** menu (see Section 5-3)

If crater fill function menus are enabled, **TIMERS** light will stay on to allow for adjustment of crater parameters and timers (see Section 5-6).

Depress **SETUP** (6) button again to exit menus and enter **MIG** welding mode.

OPERATION

Adjust welding Voltage with left knob (8) and Wire Feed Speed with right knob (9). Refer to MIG welding chart for proper Voltage and Wire Feed Speed setting in reference to material type, material thickness, wire, and gas (see Section 4-9).

ARC CONTROL

MIG welding mode: Depress **ARC CONTROL** (7) button to enter Arc control menu and **INDU** will appear on the left display and the corresponding setting will appear on the right display. Adjust right knob (9) to adjust inductance setting. In MIG welding mode the Arc control is an inductance control from 0-99. Refer to MIG welding chart for suggested Inductance setting for the wire and gas types being used (see Section 4-9). Changing the inductance will change the fluidity of the puddle.

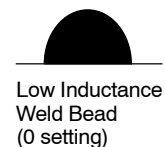

5-2. Pulse MIG Welding Mode

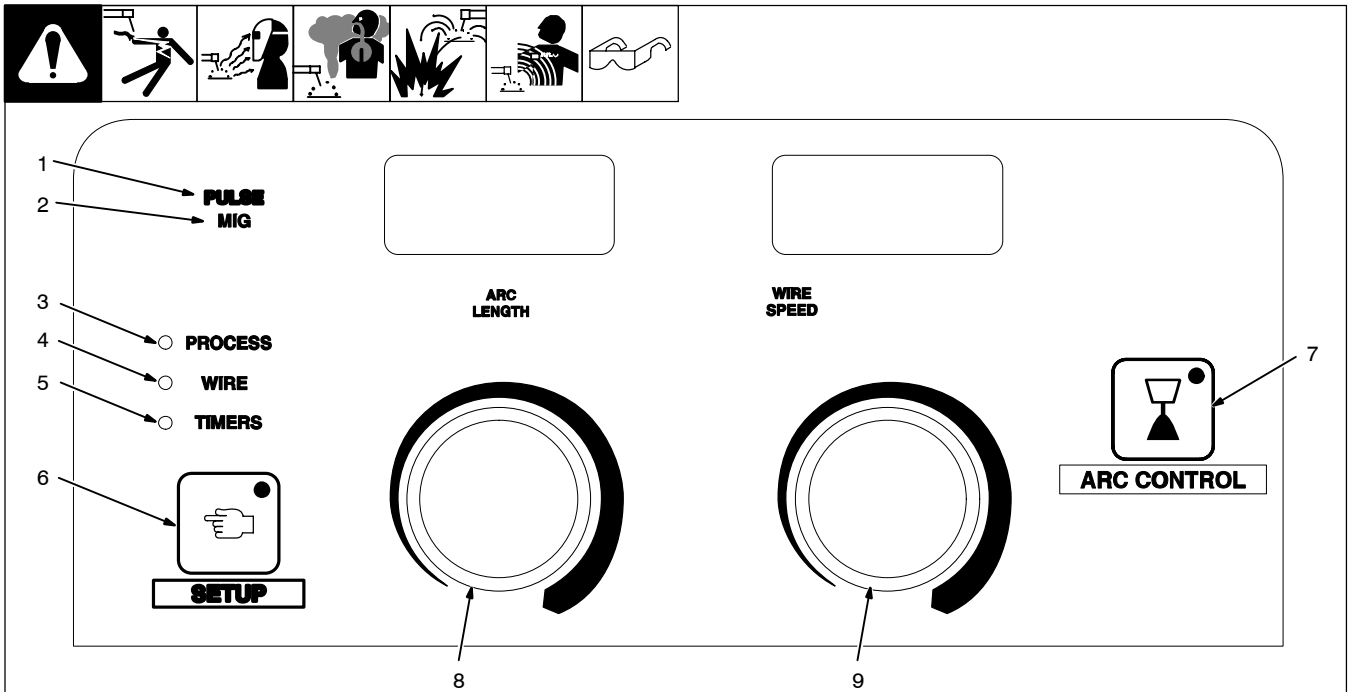

Ref. 213 935-A

When the PULSE MIG (1, 2) is illuminated, the unit is in Pulse MIG Welding mode.

SETUP

To enter Pulse MIG welding mode, depress the **SETUP** (6) button once to go to **GUN** selection. Rotate the right knob (9) to select the gun being used. Select *MIG* for standard MIG gun, or select *XR-R*, *EDGE*, *PYTH* for push pull guns, or *SPL* for spoolgun.

Depress **SETUP** (6) a second time to illuminate the **PROCESS** (3) light. Rotate right knob (9) until *PUL5* is displayed.

Depress **SETUP** (6) button again to illuminate the **WIRE** (4) light. Adjust left knob (8) to select wire type, adjust right knob (9) to select wire size.

Depress **SETUP** (6) button again to exit **WIRE** menu and enter **TIMERS** (5) menu. The **TIMERS** (5) light will illuminate. For description of the **TIMERS**, refer to **TIMERS** menu (see Section 5-3)

If crater fill function menus are enabled, **TIMERS** light will stay on to allow for adjustment of crater parameters and timers (see Section 5-6).

Depress **SETUP** (6) button again to exit menus and enter **PULSE** welding mode.

OPERATION

Adjust right knob (9) for proper Wire Feed speed and adjust left knob (8) to change Arc Length if required. Arc length will default to 50 if never adjusted previously. Refer to Pulse MIG welding chart for proper Wire Speed setting for metal and metal thickness being welded (see Section 4-9). All Pulse MIG programs are setup with the gases listed in the Pulse MIG welding chart. If alternate gases are used, adjust **Arc Length** and/or **Sharp Arc** (Arc Control) (7) to adjust arc characteristics.

ARC LENGTH

Arc length can be adjusted from 0-99. All Pulse MIG programs are set with a value of 50. Adjusting the Arc Length will vary the length of the welding arc cone.

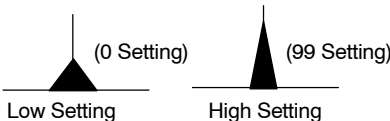

If a gas is used other than what is listed on the **Pulse MIG** welding program chart, the Arc Length can be adjusted to help customize your arc to the gas being used.

ARC CONTROL

Pulse MIG (1, 2) welding mode: Depress **ARC CONTROL** (7) button to enter Arc Control menu for sharp arc. SHRP will appear on the left display and the corresponding setting will appear on the right display. The setting can be adjusted from 0-50 and all **Pulse MIG** welding programs are designed with a setting of 25. Adjusting the Sharp Arc setting will vary the width of the welding arc cone.

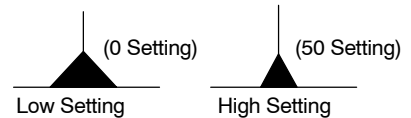

If a gas is used other than what is listed on the Pulse MIG welding program chart, the Sharp Arc can be adjusted to help customize your arc to the gas being used.

5-3. Timers

1 → PULSE MIG
2 → PULSE MIG
3 → PROCESS
4 → PROCESS
5 → WIRE
6 → TIMERS
7 → ARC CONTROL
8 → Knob
9 → Knob

Ref. 213 935-A

To enter the **TIMERS** (5) menu depress the **SETUP** (6) button 4 times or until the **TIMERS** light (5) is illuminated.

Items that can be adjusted in this menu are:

Run-in speed (R-I) – The speed of the wire prior to the welding arc being struck. This setting is a percentage of the Wire Feed Speed the unit is set to for welding. Programming value ranges from 25-150.

Preflow (PRE) – The amount of time that the shielding gas will flow after the trigger is depressed and before the welding arc will be allowed to be active. Range of setting is from 0-5 seconds.

Postflow (POST) – The amount of time that the shielding gas will flow after the arc has been shut off. Range of setting is from 0-10 seconds.

Spot Timer (SPOT) – The amount of time that the arc will be active before it shuts off automatically. Range of setting is from 0-120 seconds. Spot timer is reset upon release of welding gun trigger.

Display (DISP) – Allows the Wire Speed display to show actual welding amperage while arc is active and for 5 seconds after arc is shut off. Setting is either **AMPS** or **WFS** for standard Wire Feed Speed.

Once in the **TIMERS** (5) menu, rotate the left knob (8) to find a particular item, and rotate the right knob (9) to change setting or status.

Depress **SETUP** (6) button to get out of **TIMERS** (5) menu and to enter welding mode.

5-4. Arc Times, Arc Starts, Hot Start (Aluminum Pulse Only), And Crater Fill



Accessing the Arc Times, Arc Starts, Hot Start (aluminum pulse only), and Crater Fill data will also allow access to Software Version data and Motor Calibration function. The software version data and motor calibration function are for use by factory authorized service personnel only. Do not use the motor calibration function if it appears on the displays.

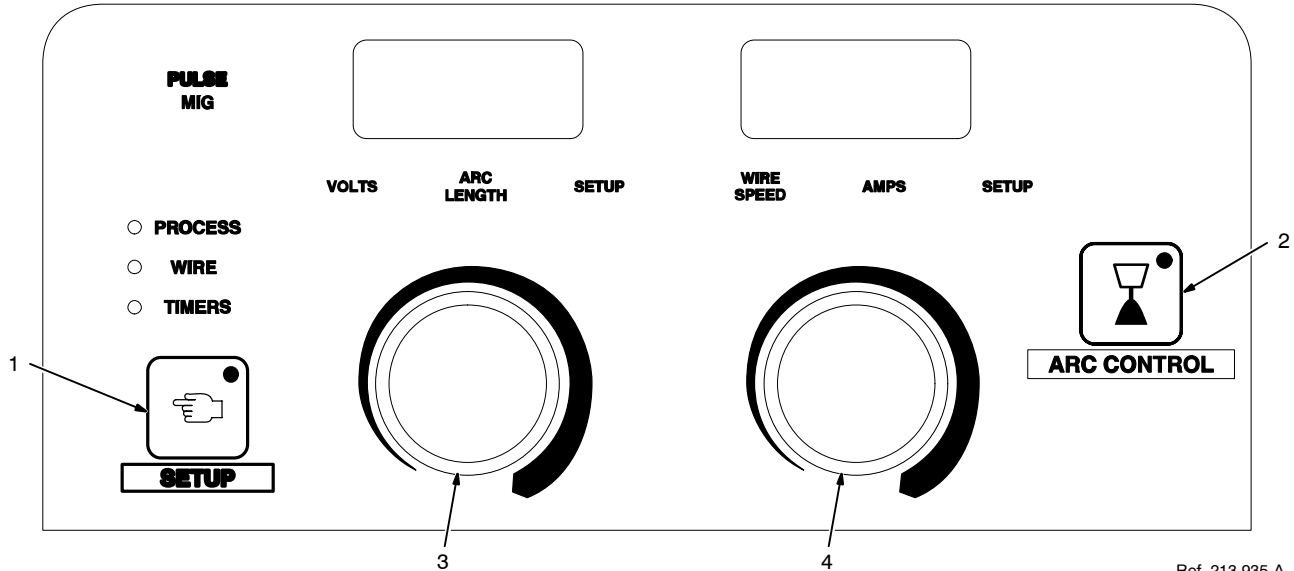

Ref. 213 935-A

Arc times and number of arc starts are saved in unit memory. To view this information, press both **SETUP** (1) and **ARC CONTROL** (2) buttons at the same time.

Left display will initially show arc hours.

Rotate left knob (3) and display will change to show number of arc starts.

To turn on the Crater Fill display, rotate left knob (3) until *CRTR* appears in the left display. The factory default for Crater Fill display is *OFF* which appears in the right display. Rotate the right knob (4) until *ON* appears in the display.

The Crater Fill display can be turned off after parameters are set in programs, but remember that once crater fill is turned on in any program, it will remain on even though it does not appear in the displays because Crater Fill display is turned off.

To exit this menu, press either the **SETUP** (1) or **ARC CONTROL** (2) button, or press a gun trigger on any welding gun connected to the unit.

5-5. Setting Hot Start (Aluminum Pulse Only) Parameters



The factory default setting for Hot Start is "Auto" on 350P models. The Auto setting has preset parameters. Hot Start can also be set to "On" (manual) for customized settings or made inactive when set to Off.

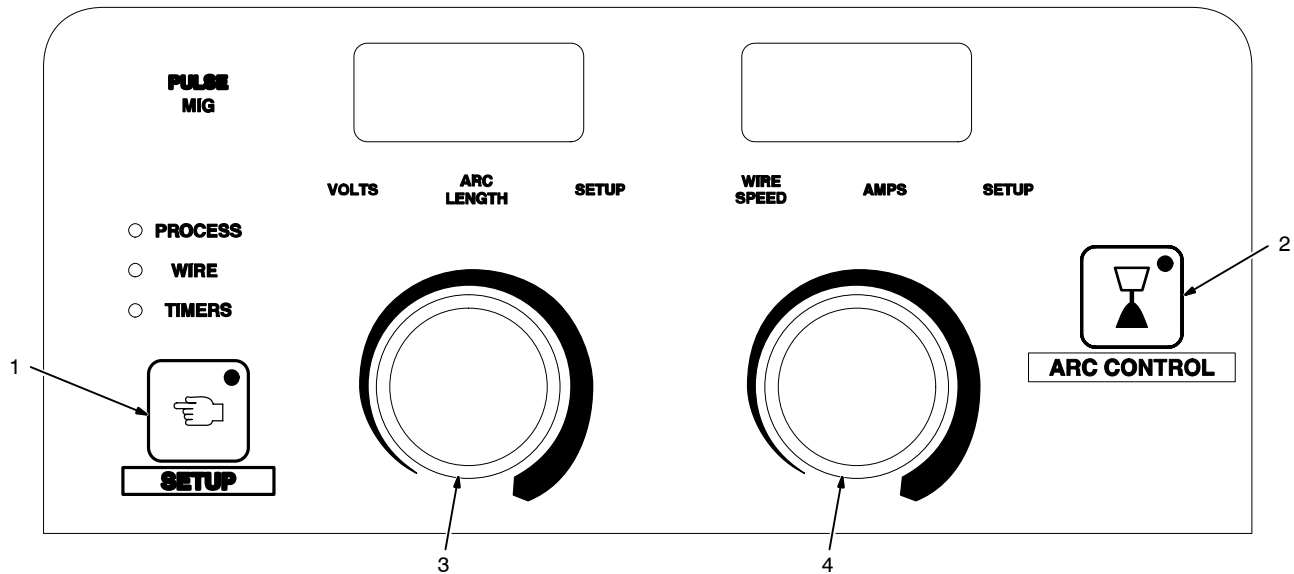

Ref. 213 935-A

To access the Setup Feature Menu, press both **SETUP** (1) and **ARC CONTROL** (2) buttons at the same time.

Left display will initially show arc hours.

Rotate left knob (3) until *RLST* appears in the left display.

Rotate right knob (4) to select hot start mode as follows:

Auto – default setting for preset hot start parameters

Off – hot start is inactive

On – allows customized setting of hot start parameters

Manual Hot Start Mode

When *RLST* appears in the left display and *00* appears in the right display, the welding power source is set for manual hot start mode.

To access hot start parameters, press the **SETUP** (1) button until *SPWR* appears in the left display.

SPWR – Start Power

Range for start power is 100-250 as a percent of wire feed speed.

SPWR maximum setting will depend on set wire feed speed and may not allow a setting of 250 under certain conditions.

STMR – Start Time

Time range is 0.0-0.5 seconds for hot start to be on.

STRL – Start Arc Length

Range for start arc length is 0-99 that changes arc length from shorter to longer.

RMPT – Ramp Time

Time range is 0.1-5.0 for the time it takes to go from hot start to set wire feed speed.

The two parameters that will have the largest influence on hot start are Start Power and Start Time. These two parameters will determine how much heat is provided and for how long at the beginning of the weld.

To exit this menu, press the **SETUP** (1) button.

5-6. Setting Crater Fill



Crater parameters are welding gun independent (i.e. crater fill can be on for a spool gun and off for a MIG gun). When using the same welding gun, MIG and pulse programs are independent of each other; however, crater parameters will be the same for all pulse programs. For example, if a MIG gun is using the .035 steel pulse program, and crater fill is on and parameters are set, crater will also be on and the same parameters will be set for a stainless pulse program.

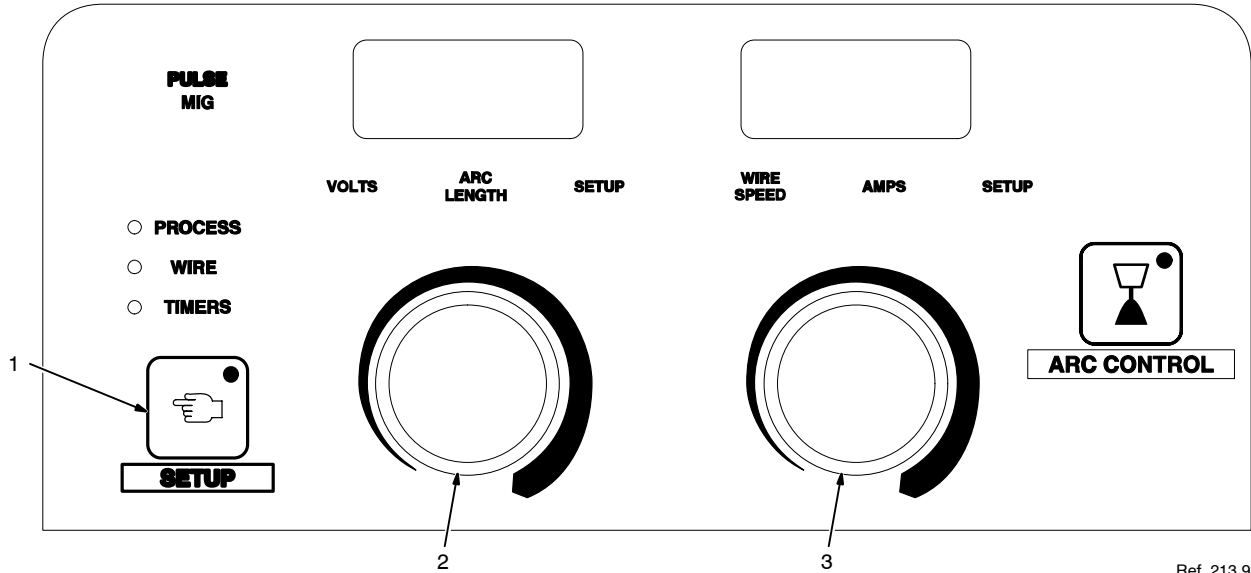

Ref. 213 935-A

To set Crater Fill, select a program and press **SETUP** (1) until the **TIMERS** LED turns on. Press **SETUP** again and the left display will show **CRTR** and the right display will show **OFF**.

Rotate right knob (3) to turn crater **ON**. Rotate left knob (2) to change display to **WFS**, and rotate right knob (3) to set crater wire feed speed. Wire feed speed range is 50-700 IPM (see Section 5-7).

Rotate left knob (2) to change display to **TIME**, and rotate right knob (3) to set crater time. Time range is 0.1-5.0 seconds (see Section 5-7).

Rotate left knob (2) to change display to **VOLT** (MIG program) or **ARCL** (pulse program), and rotate right knob (3) to set either volts (range is 10.0-32.0 volts) or arc length [range is 0-99 (see Section 5-7)].

Rotate left knob (2) to change display to **TDLY** for time delay. This setting is for spot or skip welding without crater fill if the arc time is less than the set time. Time range is 0.0-5.0 seconds (i.e. if **TDLY** is set for 2.0 seconds, weld operation will not go into crater if gun trigger is released before 2.0 seconds).

To exit this menu, press the **SETUP** (1) button.

5-7. Recommended Crater Fill Parameters

Recommended Crater Parameters

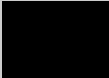
What Process are You Using?	What Material are You Welding?	Suggested Wire Types	Suggested Shielding Gases	Wire Sizes (Diameter)	
M I G					 1/2" (12.7mm)
	Steel	Solid (or hard) E70S-6	75% Co ₂ / 25% Ar	0.035" (0.9mm) 0.045" (1.1mm)	— —
	Stainless Steel	Stainless steel ER 308LSI ER 309LSI	Tri-Mix, (90% He / 7.5%Ar 2.5% Co ₂)	0.035" (0.9mm) 0.045" (1.1mm)	— —
	Steel	Metal Core	90% Ar / 10% Co ₂	0.045" (1.1mm)	400/26.7/1.0
	Aluminum	4043	100% Ar	0.035" (0.9mm) 0.047" (1.2mm)	300/22/2.0 190/21.5/1.15
	Aluminum	5356	100% Ar	0.035" (0.9mm) 0.047" (1.2mm)	— 180/18.5/1.25
	Steel	Solid (or hard) ER70S-6	90% Ar / 10% Co ₂	0.035" (0.9mm) 0.045" (1.1mm)	85/40/1.0 75/30/2.0
	Stainless Steel	Stainless steel ER 308LSI ER 309LSI	Ar / He / Co ₂ Tri-Mix	0.035" (0.9mm) 0.045" (1.1mm)	— —
	Steel	Metal Core	90% Ar / 10% Co ₂	0.045" (1.1mm)	335/45/1.0
	Aluminum	4043	100% Ar	0.035" (0.9mm) 0.047" (1.2mm)	100/35/2.0 75/20/1.5
Aluminum	5356	100% Ar	0.035" (0.9mm) 0.047" (1.2mm)	— —	
P U L S E					
	Steel	Solid (or hard) ER70S-6	90% Ar / 10% Co ₂	0.035" (0.9mm) 0.045" (1.1mm)	85/40/1.0 75/30/2.0
	Stainless Steel	Stainless steel ER 308LSI ER 309LSI	Ar / He / Co ₂ Tri-Mix	0.035" (0.9mm) 0.045" (1.1mm)	— —
	Steel	Metal Core	90% Ar / 10% Co ₂	0.045" (1.1mm)	335/45/1.0
	Aluminum	4043	100% Ar	0.035" (0.9mm) 0.047" (1.2mm)	100/35/2.0 75/20/1.5
Aluminum	5356	100% Ar	0.035" (0.9mm) 0.047" (1.2mm)	— —	

MIG SETTINGS EXAMPLE

Wire speed / Volts / Time
90 / 13.5 / 1.0

PULSE SETTINGS EXAMPLE

Wire speed / Arc length / Time
90 / 30 / 1.0

	3/8" (9.5 mm)	1/4" (6.4 mm)	3/16" (4.8 mm)	1/8" (3.2 mm)	14 ga. (2.0 mm)	16 ga. (1.6 mm)	18 ga. (1.2 mm)	19ga. (1.05mm)	20ga. (0.9mm)
	90/13.5/1.0	90/13.5/1.0	90/13.5/0.75	90/13.5/0.75	90/13.5/0.75	90/13.5/.075	90/13.5/.075	—	—
	125/19/2.0	50/15/1.0	50/15/1.0	50/15/1.0	50/15/1.0	50/15/1.0	50/15/1.0	50/15/1.0	50/15/1.0
	75/15/0.75	75/15/0.75	75/15/0.75	75/15/0.75	75/15/0.75	75/15/0.75	75/15/0.75	—	—
	75/15/1.25	75/15/1.25	75/15/1.25	75/15/0.75	75/15/0.75	75/15/0.75	75/15/0.75	—	—
	350/24.5/1.0	300/23.5/1.0	250/23/1.0	225/22.8/1.0	75/15/0.75	75/15/0.75	75/15/0.75	—	—
	300/22/2.0	200/12/1.25	200/12/1.25	150/11/1.25	200/11/0.90	—	—	—	—
	190/21.5/1.15	190/21.5/1.15	200/19.5/1.25	215/17/1.0	—	—	—	—	—
	—	250/19.5/1.25	250/17/1.25	250/17/1.25	—	—	—	—	—
	180/18.5/1.25	180/18.5/1.25	180/16/1.25	180/16/1.25	—	—	—	—	—
	85/40/1.0	85/30/1.0	85/30/1.0	85/30/1.0	85/30/1.0	85/30/1.0	85/30/1.0	—	—
	75/30/2.0	75/30/2.0	75/30/1.5	75/30/1.0	75/30/1.0	75/30/0.75	75/30/0.75	—	—
	90/30/1.0	90/30/1.0	90/30/1.0	90/30/1.0	90/30/0.75	90/30/0.75	75/30/0.75	—	—
	75//30/2.0	75//30/2.0	75/30/1.0	75/30/1.0	75/30/1.0	50/30/0.75	50/30/.075	—	—
	275/45/1.0	230/45/1.0	175/50/1.0	150/50/1.0	130/45/1.0	115/40/1.0	115/40/1.0	—	—
	100/35/2.0	100/35/2.0	100/35/2.0	100/35/1.5	100/20/1.5	100/25/1.2	100/25/1.2	100/35/1.0	—
	75/20/1.5	75/20/1.5	75/20/1.5	75/20/1.5	75/20/1.5	75/20/1.0	75/20/1.0	—	—
	—	120/30/1.75	120/30/1.50	120/30/1.50	120/30/1.0	120/30/1.0	120/30/1.0	120/30/1.0	—
	—	105/30/1.50	105/30/1.50	105/30/1.25	105/30/1.0	105/30/1.0	105/30/0.75	—	—

5-8. System Reset



Accessing the System Reset function will also allow access to Timer Reset (*RTTR*) and Option Reset (*ORS*) functions. The timer reset and option reset functions are for use by factory authorized service personnel only. Do not use the timer reset or option reset functions if they appear on the displays.

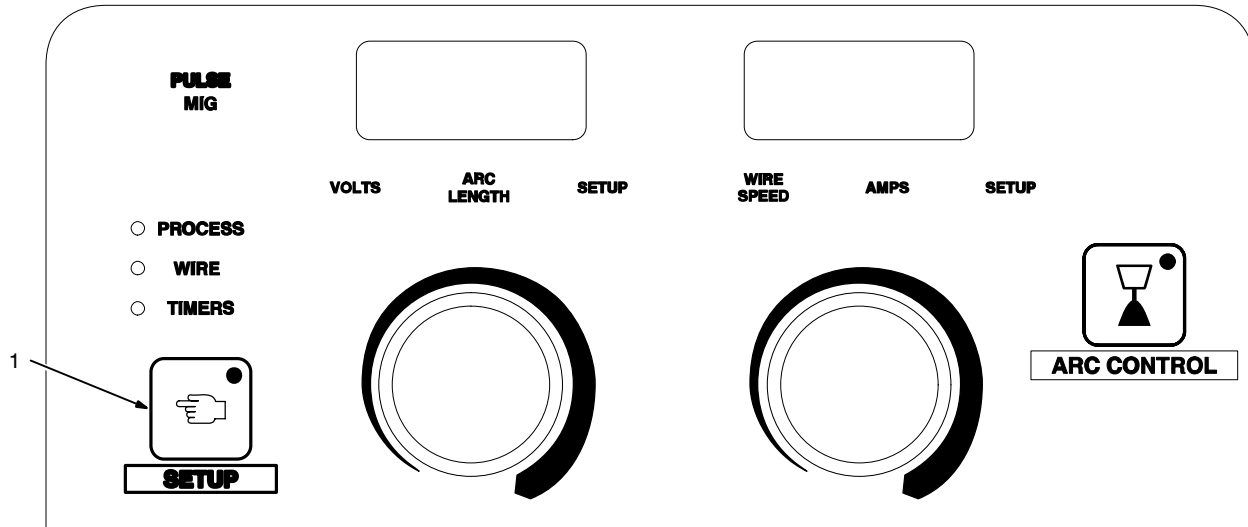

Ref. 213 935-A

A system reset function is available that completely resets unit back to all the original factory settings.

To access this menu, turn on welding power source, then press the **SETUP** (1) button when the SETUP light illuminates under the Left display.

SRST will appear on the left display and *OFF* will appear on the right display.

To prepare the unit for system reset, rotate right knob until *ON* appears on the right display.

To apply the system reset function, press **SETUP** (1) button, and wait until unit completely reboots before performing any other operations.

SECTION 6 – MAINTENANCE & TROUBLESHOOTING

6-1. Routine Maintenance

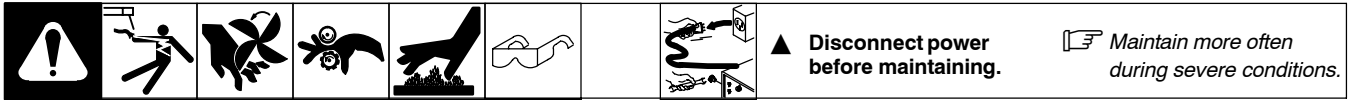

3 Months			
Replace unreadable labels		Repair or replace cracked weld cable	
Clean and tighten weld terminals		Check gun cable.	
6 Months			
Blow out or vacuum inside.		Clean drive rolls.	

6-2. Overheating

Thermistors RT1 and RT2 protect the unit from damage due to overheating. If output diode heatsink or IGBT heatsink gets too hot, RT1 and/or RT2 opens and output stops. The fan keeps running to cool the unit. Wait several minutes before trying to weld.

6-3. Measuring Input Capacitor Voltage

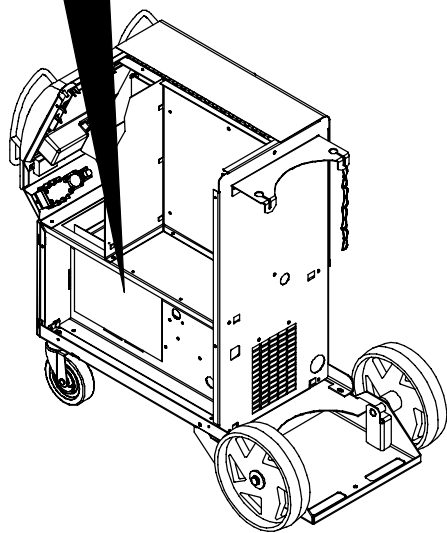
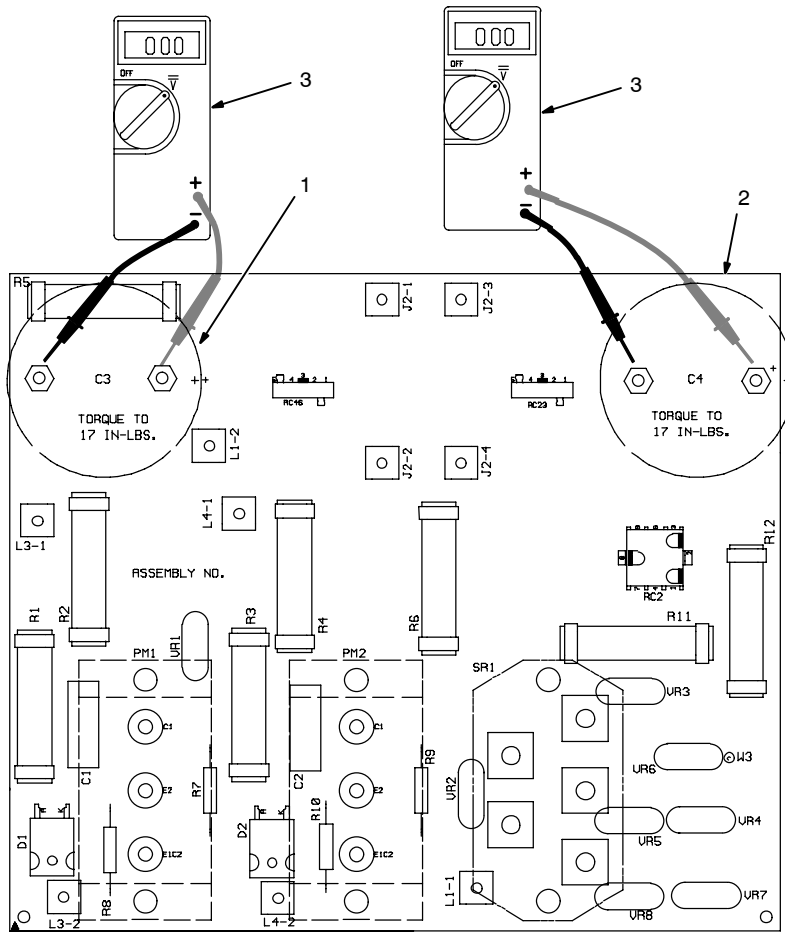

Tools Needed:

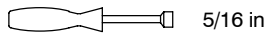

▲ Significant DC voltage can remain on capacitors after unit is Off. Always check capacitors as shown to be sure they have discharged before working on unit.

Turn Off welding power source and disconnect input power.

Remove case.

- 1 Input Capacitor C3 Terminals
- 2 Input Capacitor C4 Terminals
- 3 Voltmeter

Check input capacitors as shown.

Measure the dc voltage across the positive (+) and negative (-) terminals until voltage drops to near 0 (zero) volts.

Proceed with job inside unit. Reinstall case when finished.

6-4. Changing Drive Roll and Wire Inlet Guide

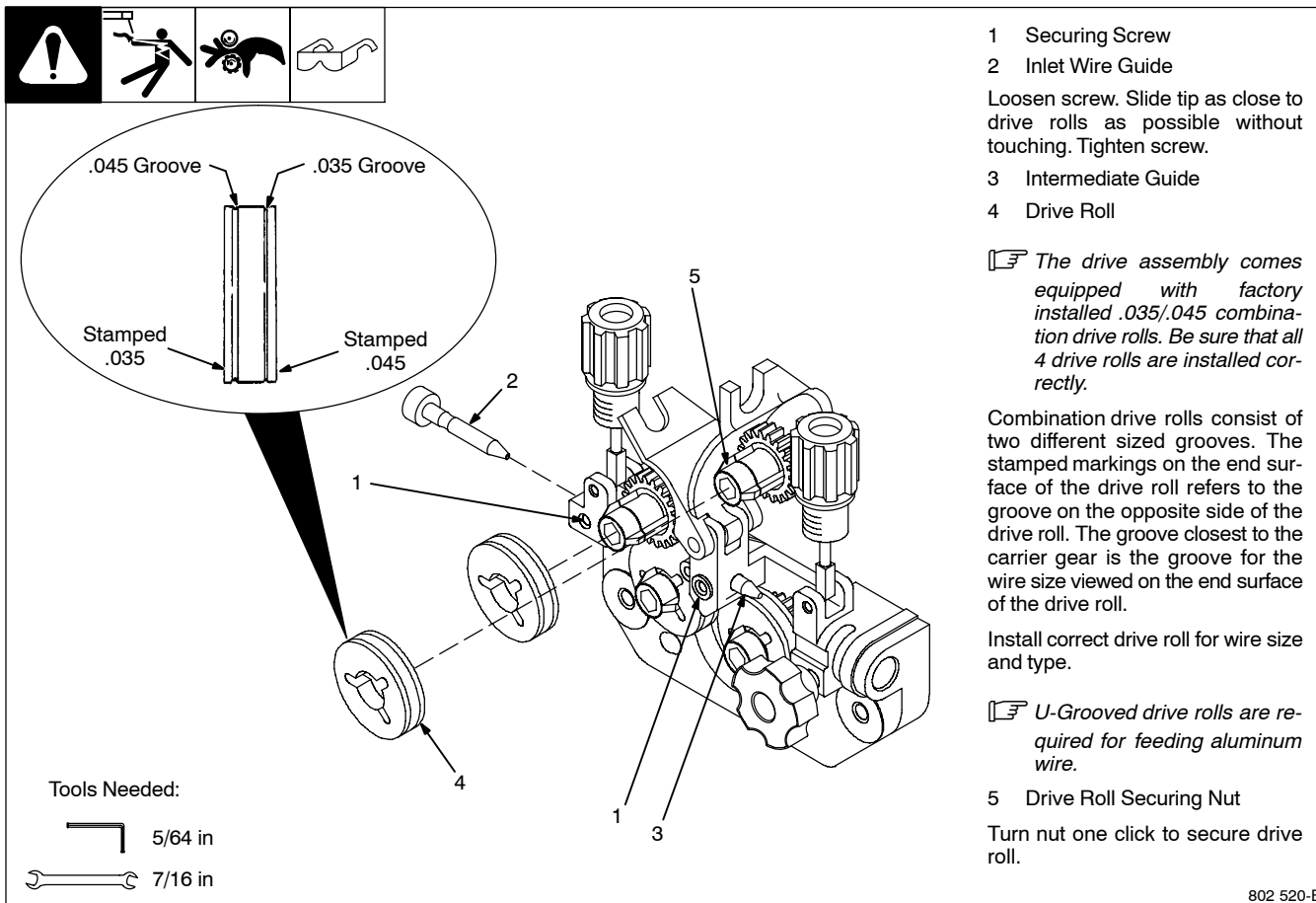

6-5. Troubleshooting



Trouble	Remedy
No weld output; wire does not feed.	Be sure line disconnect switch is On (see Section 3-15 or 3-16).
	Replace building line fuse or reset circuit breaker if open (see Section 3-15 or 3-16).
	Secure gun trigger connections (see Section 3-7).
	Have Factory Authorized Service Agent check Power switch.
	Have Factory Authorized Service Agent check all board connections and main control board.
No weld output; wire feeds.	Thermistor RT1 or RT2 open (overheating). Allow fan to run; the unit will be enabled when it has cooled and temperatures are within acceptable limits (see Section 3-2 and 6-2).
	Connect work clamp to get good metal to metal contact.
	Replace contact tip (see gun Owner's Manual).
	Have Factory Authorized Service Agent check main control board and main rectifier.
Low weld output.	Connect unit to proper input voltage or check for low line voltage (see Section 3-15 or 3-16).
	Have Factory Authorized Service Agent check main control board and user interface board.
Low, high, or erratic wire speed.	Readjust front panel settings (see Section 4-1).
	Change to correct size drive rolls (see Section 6-4).
	Readjust drive roll pressure (see Section 3-17).
	Replace inlet guide, contact tip, and/or liner if necessary (see gun Owner's Manual).
	Have Factory Authorized Service Agent check input voltage.
	Have Factory Authorized Service Agent check main control board.
No wire feed.	Turn Wire Speed control to higher setting (see Section 4-1).
	Clear obstruction in gun contact tip or liner (see gun Owner's Manual).
	Readjust drive roll pressure (see Section 3-17).
	Change to correct size drive rolls (see Section 6-4).
	Rethread welding wire (see Section 3-17).
	Check gun trigger and leads. Repair or replace gun if necessary.
	Have Factory Authorized Service Agent check main control board and user interface board.
	H – – message appears on voltmeter and ammeter displays to indicate thermistor RT1 or RT2 is open and unit is in an overheated condition (see Section 6-6).

6-6. Help Displays

V A
HELP 0

V A
HELP 8

V A
HELP 1

V A
HELP 9

V A
HELP 2

V A
HELP 10

V A
HELP 3

V A
HELP 11

V A
HELP 4

V A
TIP SAVE

V A
HELP 5

V A
MM 350P

V A
HELP 6

V A
MM 350

V A
HELP 7

V A
JOG XXX



Displays a jog wire feed speed.

 All directions are in reference to the front of the unit. All circuitry referred to is located inside the unit.

- **Help 0**

Indicates overheating on left side of unit (displays flash between OVER TEMP and HELP 1). Unit will shutdown until internal temperature drops within operational range.

- **Help 1**

Turn off primary input power and check input voltage per primary voltage rating of welder, and correct if necessary. If HELP 1 persists, this indicates a communication error between control board PC1 and user interface board. Contact nearest Factory Authorized Service Agent.

- **Help 2**

Indicates overheating on right side of unit (displays flash between OVER TEMP and HELP 2). Unit will shutdown until internal temperature drops within operational range.

- **Help 3**

Indicates gun trigger was pulled and held during power up. Release gun trigger and clear fault condition. Also, this display can indicate no open circuit voltage detected when gun trigger is pulled and no arc detected within 3 seconds. Turn off primary input power and contact a Factory Authorized Service Agent.

- **Help 4**

Indicates gun trigger was pulled and held for 2 minutes without a welding arc established or there is a direct short between contact tip or wire and the workpiece. Release gun trigger and clear fault condition.

- **Help 5**

Indicates a malfunction in wire feed system and/or drive motor overcurrent condition. Check for proper spool brake adjustment or obstructions in wire feed system. Clean or replace liner, wire guides, or contact tip.

- **Help 6**

Indicates a malfunction in wire feed system and/or external drive motor overcurrent condition (spool gun or push-pull gun). Check for proper spool brake adjustment or obstructions in wire feed system. Clean or replace liner, wire guides, or contact tip.

- **Help 7**

Indicates input voltage malfunction (voltage too high or too low) causing unit to automatically shut down. Turn off input primary power and check input voltage per primary voltage rating of welder. Unit will operate once input voltage is within specification and power to unit is turned off and back on.

- **Help 8**

Indicates a malfunction in the secondary power circuit of the unit. Check control board PC1, and primary and secondary connections.

- **Help 9**

Indicates a malfunction in Pulse MIG function. Check connection between pulse board and user interface board. Replace pulse board, if necessary.

- **Help 10**

Indicates a trigger error when two gun triggers are activated at the same time. Release gun triggers to clear error.

- **Help 11**

Indicates a tach error when tach feedback signal is not present. Release and press gun trigger to reset tach signal. If error continues, contact a Factory Authorized Service Agent.

- **Tip Save**

Indicates contact tip is directly shorted to workpiece. Arc shuts off in this condition, and message resets when tip is not touching workpiece and gun trigger is released.

- **MM 350P**

When unit is turned on, this display indicates that pulse option is installed and operational.

- **MM 350**

When unit is turned on, this display indicates that unit is either a MIG only machine or pulse option is installed but not operational.

- **Jog XXX (Wire Feed Speed)**

Indicates trigger is pressed, but no arc is detected. Wire feed speed goes to Jog wire feed speed after 3 seconds.

SECTION 7 – ELECTRICAL DIAGRAM

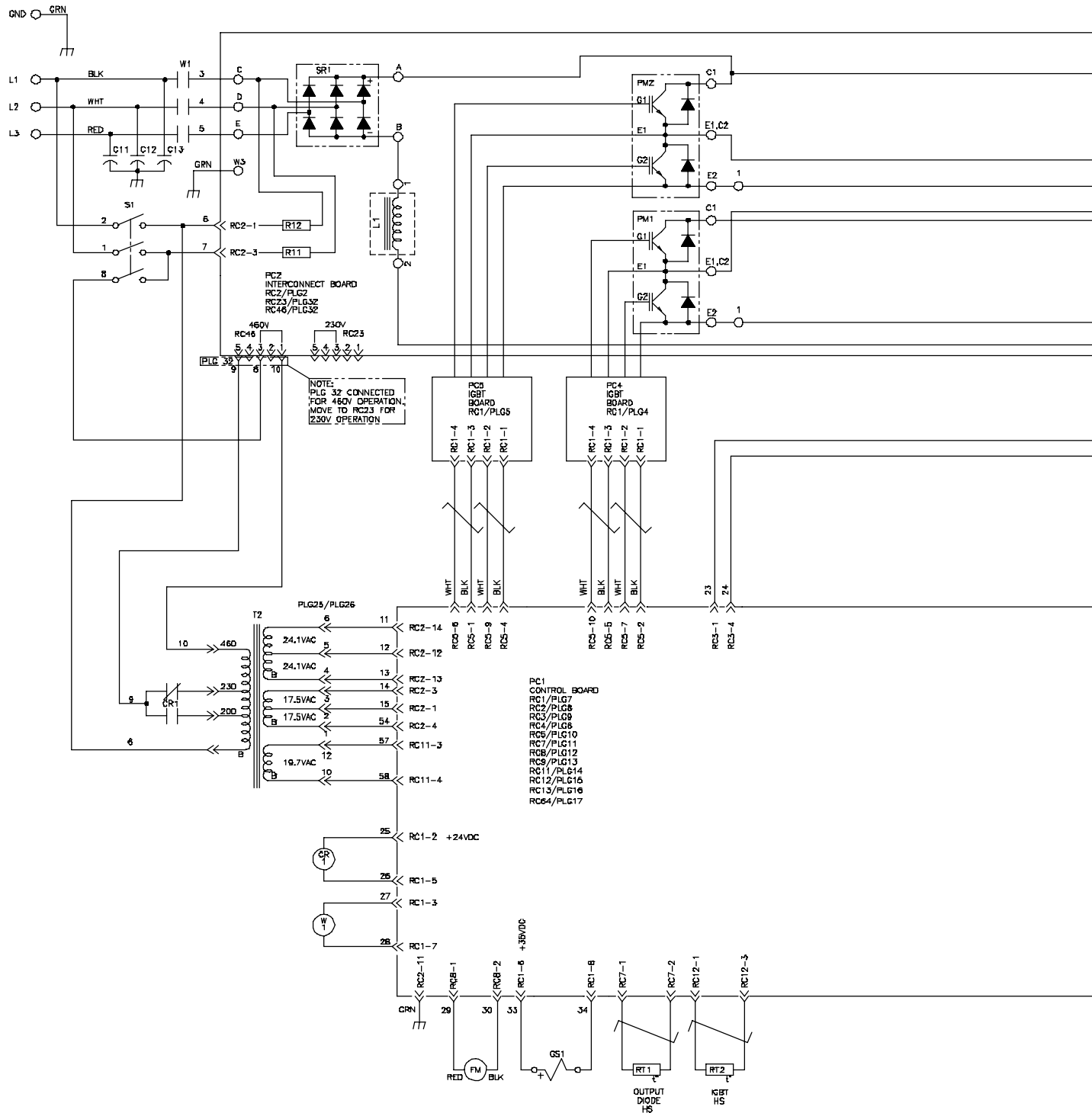

	<p>WARNING</p> <ul style="list-style-type: none"> Do not touch live electrical parts. Disconnect input power or stop engine before servicing. Do not operate with covers removed. Have only qualified persons install, use, or service this unit.
	<p>ELECTRIC SHOCK HAZARD</p>

Figure 7-1. Circuit Diagram For 200V/230V/460V Models

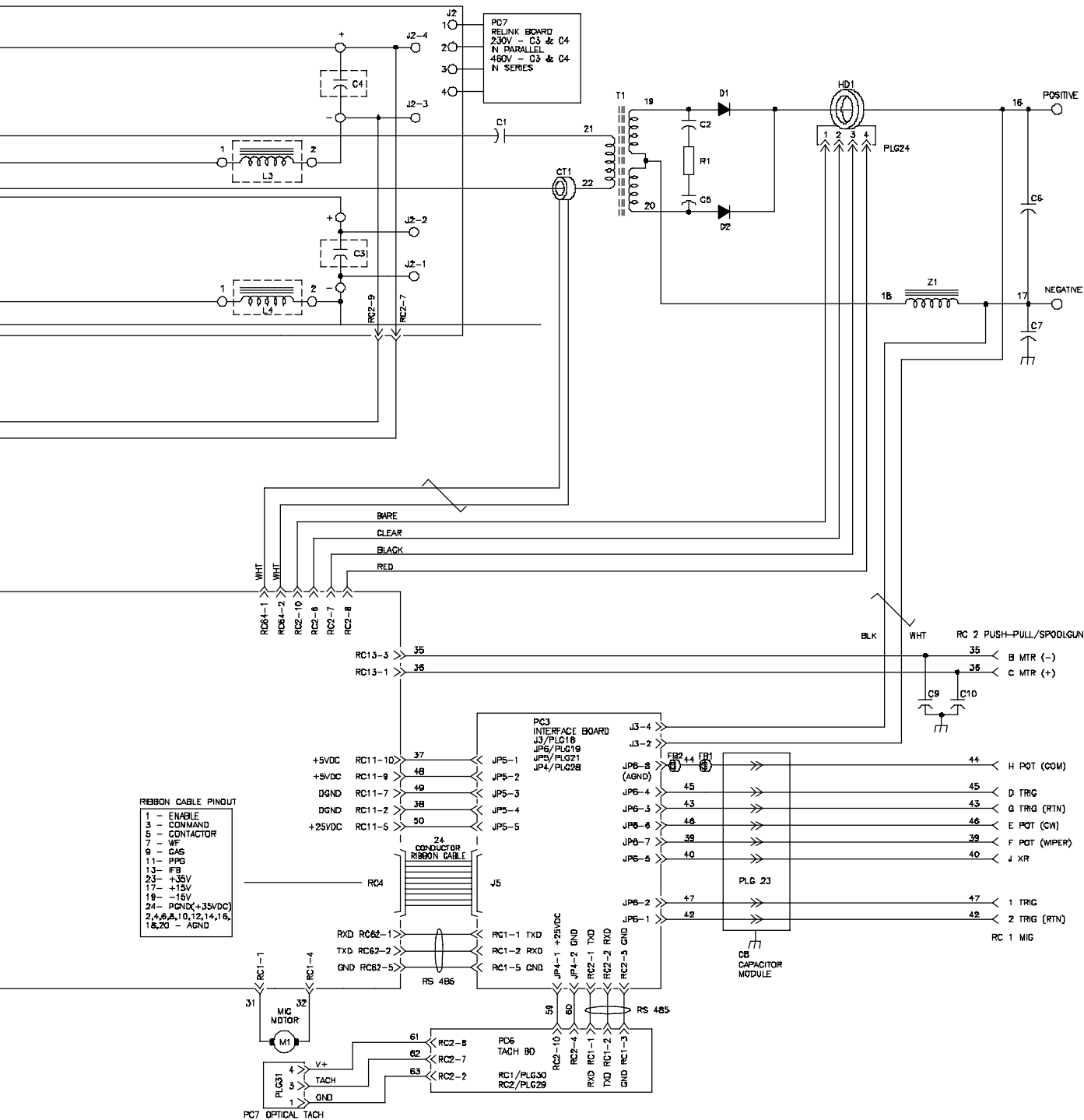

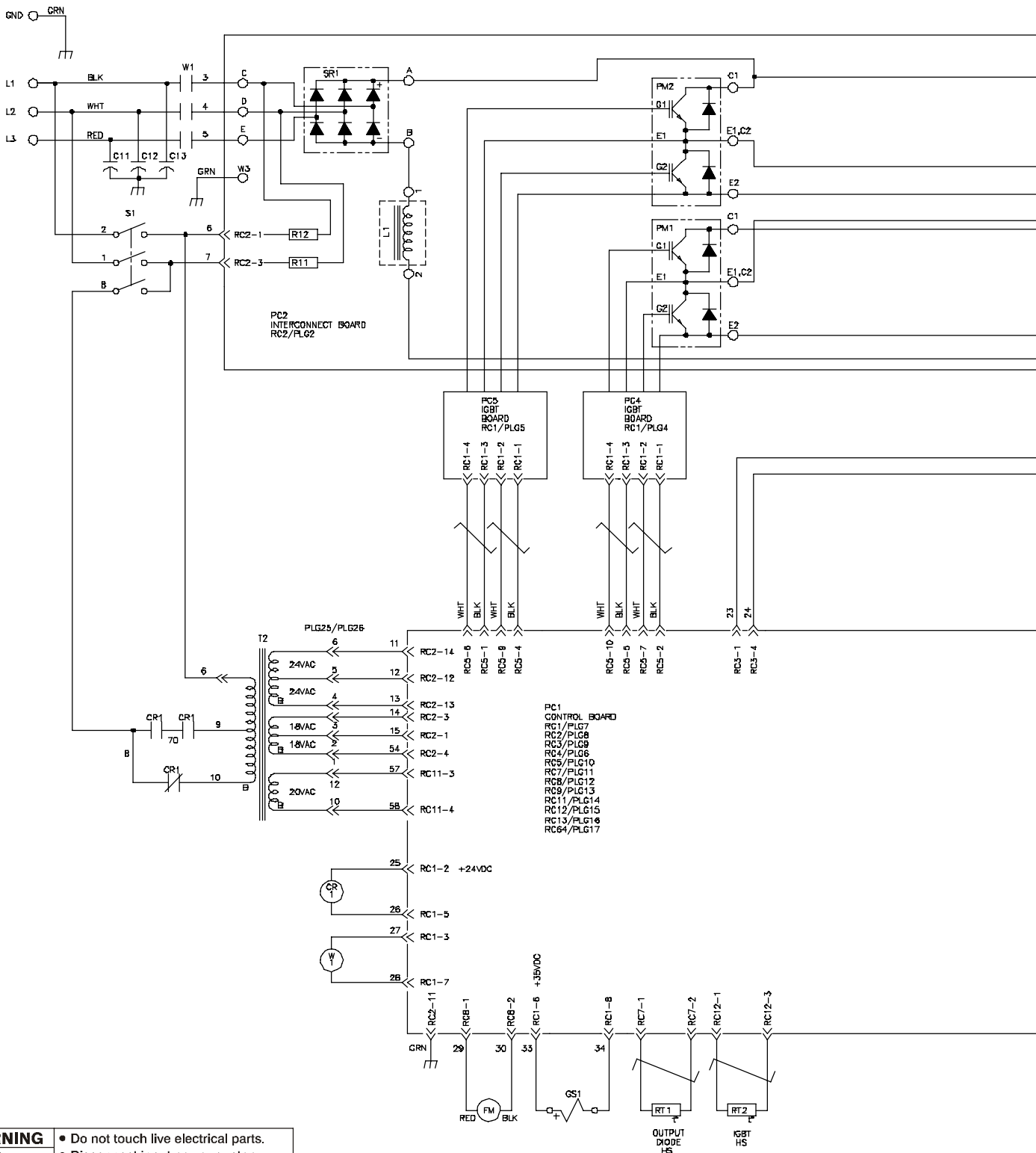

 ELECTRIC SHOCK HAZARD	WARNING
	<ul style="list-style-type: none"> • Do not touch live electrical parts. • Disconnect input power or stop engine before servicing. • Do not operate with covers removed. • Have only qualified persons install, use, or service this unit.

Figure 7-2. Circuit Diagram For 460V/575V Models

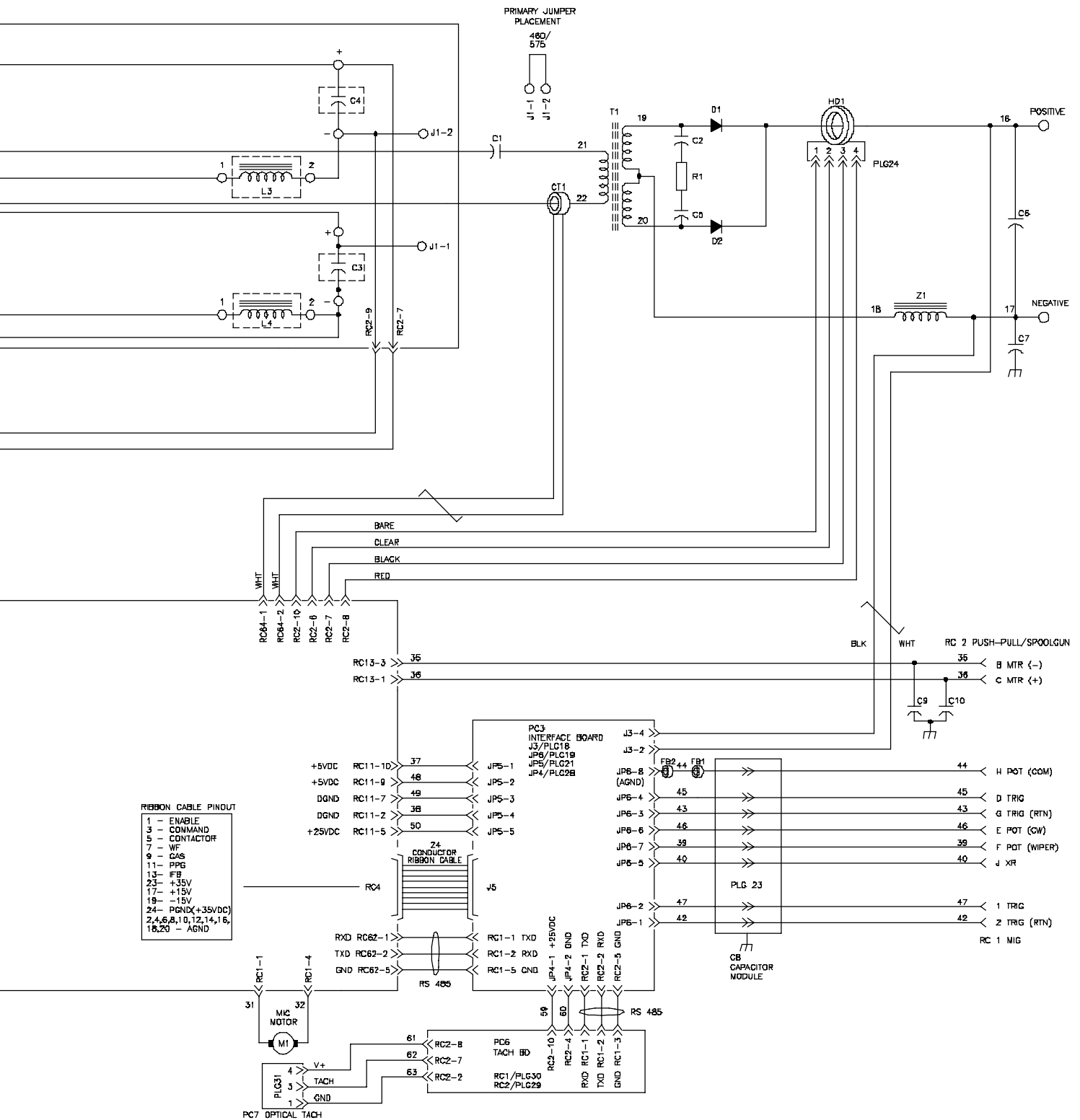

SECTION 8 – PARTS LIST

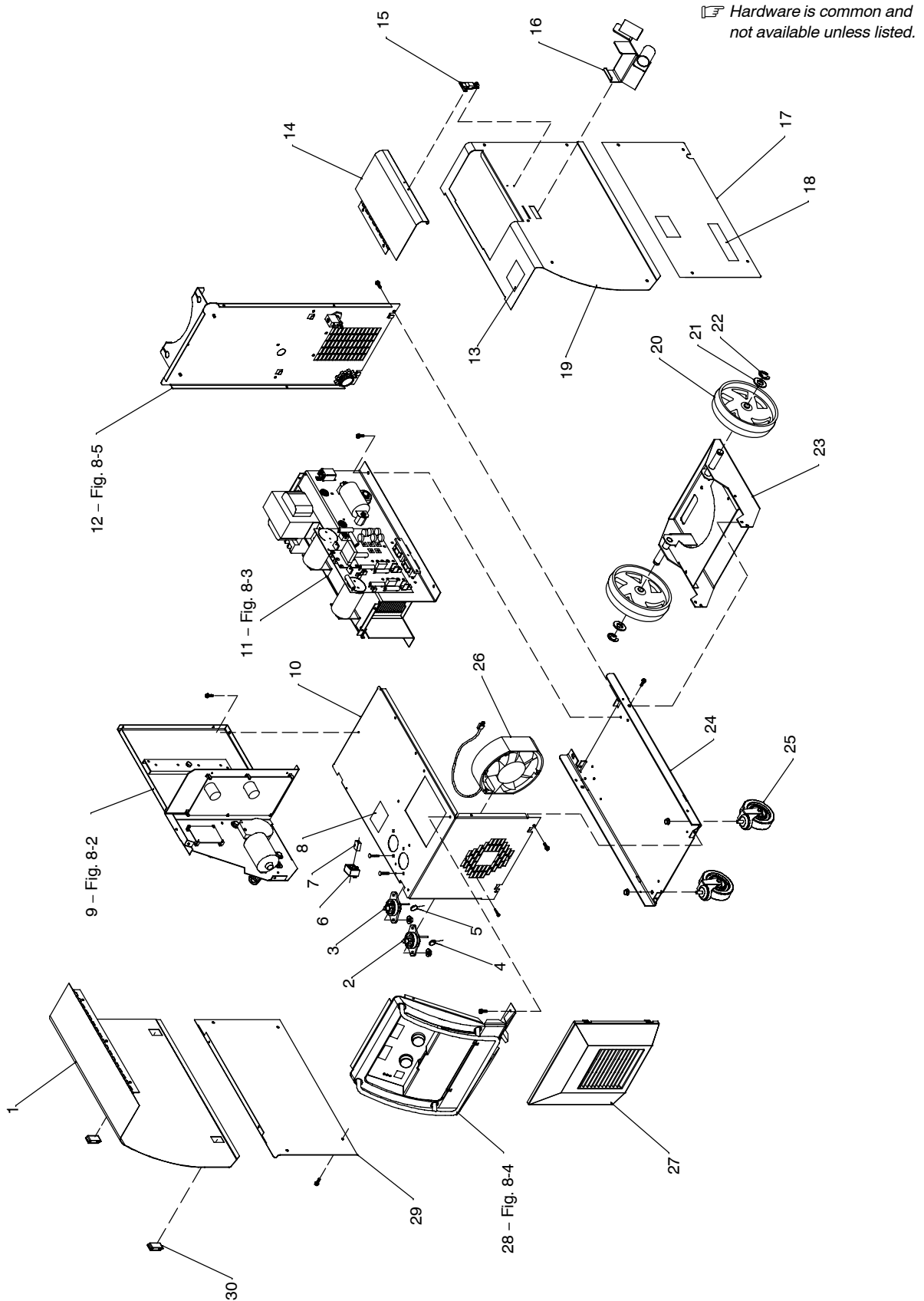

Figure 8-1. Main Assembly

Item No.	Dia. Mkgs.	Part No.	Description	Quantity
----------	------------	----------	-------------	----------

Figure 8-1. Main Assembly

...	1	212829	DOOR,ACCESS WIRE COMPARTMENT	1
...	2	NEG 097416	TERMINAL,PWR OUTPUT BLACK	1
...	3	POS 097421	TERMINAL,PWR OUTPUT RED	1
...	4	C6 232049	CAPACITOR	1
...	5	C7 232050	CAPACITOR	1
...	6	HD1 189567	TRANSDUCER,CURRENT 400A MODULE SUPPLY V +/- 15V	1
...		183046	CABLE,LEM	1
...	7	221326	BUS BAR,CURRENT SENSOR	1
...	8	199824	LABEL,WARNING ELECTIC SHOCK AND PINCH POINTS	1
...	9	Fig 8-2	BAFFLE,CENTER	1
...	10	212821	PANEL,FRONT LOWER	1
...	11	Fig 8-3	INVERTER ASSY	1
...	12	+Fig 8-5	PANEL,REAR	1
...	13	134464	LABEL,WARNING GENERAL PRECAUTIONARY STATIC&WIRE	1
...	14	212826	DOOR,ACCESS TOOL COMPARTMENT	1
...	15	217829	LATCH,DOOR STRAIGHT LOOP CATCH	1
...	16	215061	GUN/CABLE HOLDER	1
...	17	+222288	PANEL,SIDE RH LOWER (200/230/460V model)	1
...		180994	LABEL,WARNING MATCH INPUT POWER (200/230/460V model)	1
...		222325	LABEL,WARNING INPUT POWER RELINK (200/230/460V model)	1
...	18	213939	LABEL,WARNING ELECTRIC SHOCK CAN KILL SIGNIFICANT	1
...	19	+222287	WRAPPER (200/230/460V model)	1
...	18	+212823	WRAPPER (460/575V model)	1
...	20	186758	WHEEL,POLYPROPYLENE 10 IN X 2.25 WIDE	2
...	21	602250	WASHER,FLAT .812IDX1.469ODX.134T STL PLD ANSI.750	2
...	22	121614	RING,RTNG EXT .750 SHAFT X .085 THK E STYLE PLD	2
...	23	213903	RACK,CYLINDER SINGLE	1
...	24	212833	BASE,	1
...	25	209870	CASTER,SWVL 4.00 IN X 1.250 IN POLY-OLEFIN	2
...	26	FM 213043	FAN,MUFFIN 24VDC 3000 RPM W/20.500 IN LEADS	1
...	27	212846	BEZEL,LOWER	1
...	28	Fig 8-4	PANEL,FRONT	1
...	29	212822	PANEL,SIDE LH LOWER	1
...	30	151187	LATCH,SLIDE FLUSH MTG HOLE 1.000 WIDEX 1.500 LG	2
...		209123	REGULATOR/FLOWMETER,10-50 CFH ARGON/MIX (350 MODEL)	1
...		210925	REGULATOR/FLOWMETER,0-50 CFH AR/CO2 W/FLOWTUBE(350P MODEL)	1
...		144108	HOSE,GAS 5FT	1
...		196329	CABLE,WORK 10 FT NO1 W/CLAMP & BOOT (350 MODEL) (INCLUDING)	1
...		130750	CLAMP,WORK 300 AMP	1
...		196318	COVER,CABLE BTRY POST BLK .75 ID	1
...		213369	CABLE,WORK 10 FT 1/O W/CLAMP & BOOT (350P MODEL) (INCLUDING)	1
...		213619	CLAMP,WORK 300 AMP STL CHROME PLD W/COP CONTACTS	1
...		196318	COVER,CABLE BTRY POST BLK .75 ID	1
...		♦212492	REGULATOR/FLOWMETER, 0-50 CFH CO2	1
...		†229 560	Q300 AMP GUN, 15FT .045 STL W/FLUSH COPPER NOZZLE	1

+When ordering a component originally displaying a precautionary label, the label should also be ordered.

♦OPTIONAL

†See welding gun Owner's Manual for additional information.

To maintain the factory original performance of your equipment, use only Manufacturer's Suggested Replacement Parts. Model and serial number required when ordering parts from your local distributor.

☞ Hardware is common and not available unless listed.

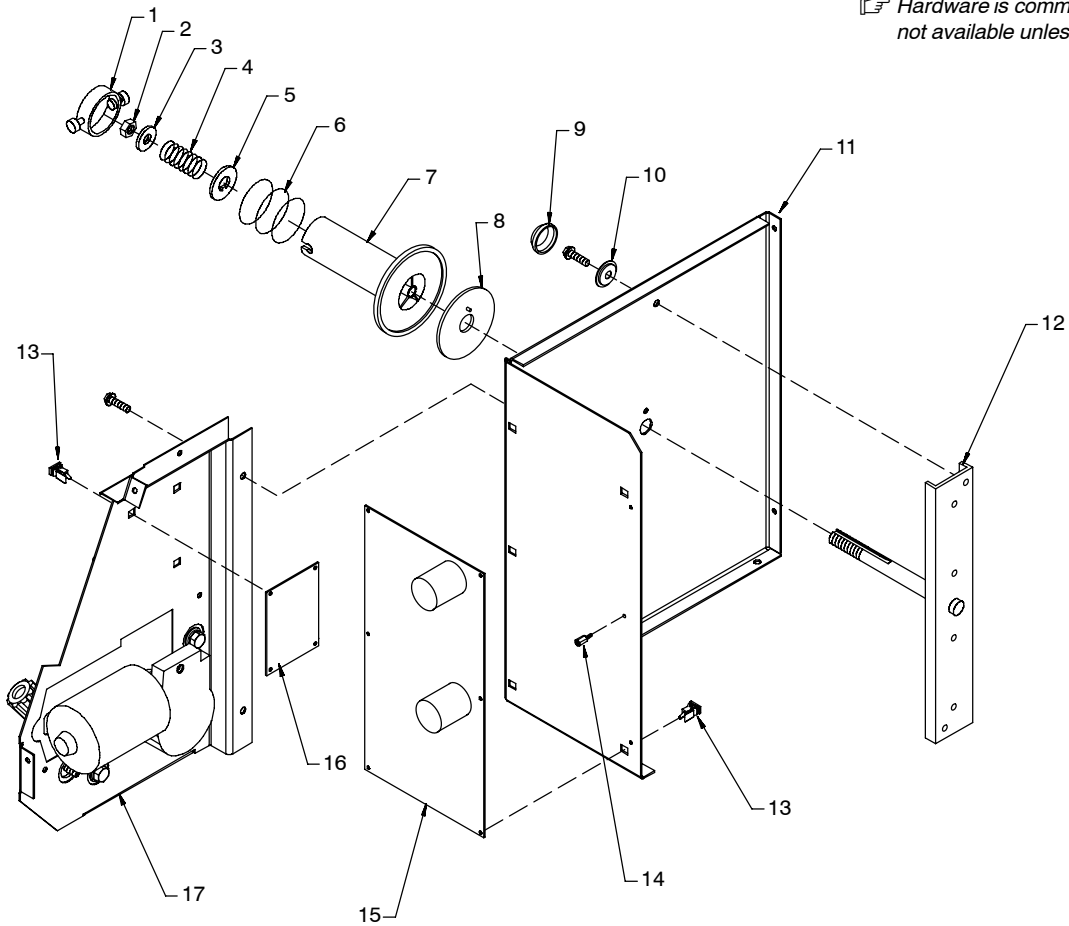

803 546-C

Figure 8-2. Baffle, Center w/Components

Item No.	Dia. Mkgs.	Part No.	Description	Quantity
----------	------------	----------	-------------	----------

Figure 8-2. Baffle, Center w/Components (Fig 8-1 Item 7)

.. 1		058427	.. RING,RETAINING SPOOL	1
.. 2		085980	.. NUT,STL HEX FULL .625-11	1
.. 3		605941	.. WASHER,FLAT STL .640 ID X 1.000 OD X 14GA THK	1
.. 4		186437	.. SPRING,CPRSN .845 OD X .110 WIRE X 1.500	1
.. 5		057971	.. WASHER,FLAT STL KEYED 1.500DIA X .125THK	1
.. 6		057745	.. SPRING,CPRSN 2.305 OD X .090 WIRE X 2.500 PLD	1
.. 7		186435	.. HUB,SPOOL	1
.. 8		186436	.. WASHER,BRAKE PLASTIC	1
.. 9		198425	.. CAP,FINISHING 1.19 X .37	2
.. 10		198426	.. WASHER,CAP	2
.. 11		223921	.. BAFFLE,CENTER	1
.. 12		177307	.. REEL SUPPORT	1
.. 13		134201	.. STAND-OFF SUPPORT,PC CARD .312/.375W/POST&LOCK .43	9

Item No.	Dia. Mkgs.	Part No.	Description	Quantity
----------	------------	----------	-------------	----------

Figure 8-2. Baffle, Center w/Components (Fig 8-1 Item 7) (Continued)

. 14		204310	.. STAND-OFF,NO 6-32 X .437 LG .250 HEX AL M&F	1
. 15	PC1	223542	.. KIT,MM350 CONTROL BOARD W/ INSTRUCTIONS (200/230/460V model)	1
. 15	PC1	223670	.. KIT,MM350 CONTROL BOARD W/ INSTRUCTIONS (460/575V model)	1
	PLG9	115093	.. HOUSING PLUG+SKTS,(SERVICE KIT)	1
	PLG7	115092	.. HOUSING PLUG+SKTS,(SERVICE KIT)	1
	PLG8	131056	.. HOUSING RCPT+SKTS,(SERVICE KIT)	1
	PLG10,14	115091	.. HOUSING PLUG+SKTS,(SERVICE KIT)	2
	PLG11,12,			
	17	131054	.. HOUSING PLUG+SKTS,(SERVICE KIT)	3
	PLG15,16	131204	.. HOUSING PLUG+SKTS,(SERVICE KIT)	2
		213404	.. CABLE,INTERCONNECTING RS 485 INTERFACE TO CONTROL	1
		213405	.. CABLE,INTERCONNECTING RS 485 INTERFACE TO PULSE OP	1
		168674	.. CABLE,RIBBON 24 POSN 14.000 IN SKTS BE INVERTED	1
. 16	PC6	216342	.. CIRCUIT CARD ASSY,GMAW PULSE W/PROGRAM (PULSE MODEL ONLY)	1
	PLG29	131204	.. HOUSING PLUG+SKTS,(SERVICE KIT)	1
	PLG30	115091	.. HOUSING PLUG+SKTS,(SERVICE KIT)	1
. 17		Fig 8-6	.. DRIVE ASSY,WIRE 4 ROLL	1

To maintain the factory original performance of your equipment, use only Manufacturer's Suggested Replacement Parts. Model and serial number required when ordering parts from your local distributor.

☞ Hardware is common and not available unless listed.

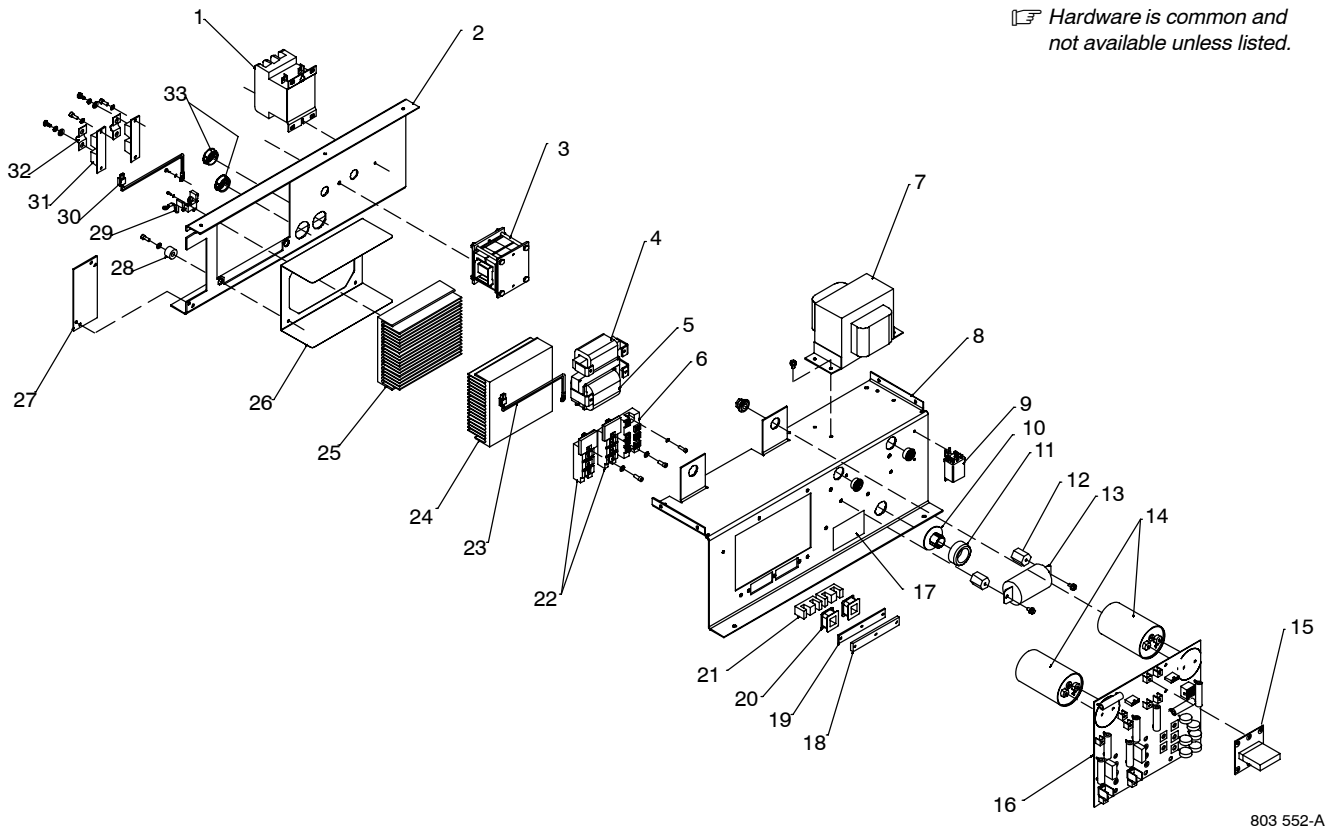

Figure 8-3. Inverter Assy

Item No.	Dia. Mkgs.	Part No.	Description	Quantity
----------	------------	----------	-------------	----------

Figure 8-3. Inverter Assy (Fig 8-1 Item 9)

...	1	W	188634	.. CONTACTOR,DEF PRP 60A 3P 24VAC COIL W/COVER	1
.....		C11,12,			
		13	148240	.. CAPACITOR,CER DISC .003 UF 2000 VAC W/TERMS	3
...	2	+212750		.. WINDTUNNEL,LH	1
.....		185835		.. LABEL,WARNING ELECTRIC SHOCK/EXPLODING PARTS	1
...	3	T1	180952	.. XFMR,HF	1
...	4	L1	222392	.. INDUCTOR,INPUT (200/230/460V model)	1
...	4	L1	216006	.. INDUCTOR,INPUT (460/575V model)	1
...	5	Z1	212756	.. STABILIZER,OUTPUT	1
...	6	SR1	212937	.. KIT,POWER MODULE	1
...	7	T2	224238	.. XFMR,CONTROL 200/230/460 PRI	1
...	7	T2	223922	.. XFMR,CONTROL 460/575 PRI	1
.....		PLG26	168071	.. HOUSING PLUG PINS+SKTS,(SERVICE KIT)	1
...	8	+212752		.. WINDTUNNEL,RH	1
...	9	CR1	106462	.. RELAY,ENCL 24VDC DPDT 20A/120VAC 8PIN FLANGE MTG	1
...	10		177547	.. BUSHING,SNAP-IN NYL CT-MOUNT 1.125 MTG HOLE	1
...	11	CT1	213032	.. XFMR,CURRENT	1
...	12		025248	.. STAND-OFF,INSUL .250-20 X 1.250 LG X .437 THD	2
...	13	C1	186015	.. CAPACITOR,POLYP FILM .34 UF 1000 VAC +8% -0% (200/230/460V model)	1
...	13	C1	193858	.. CAPACITOR,POLYP FILM .27 UF 1000 VAC +8% -0% (460/575V model) .	1
...	14	C3,4	192935	.. CAPACITOR,ELCTLT 2700 UF 450 VDC CAN 2.52 DIA (200/230/460 MODELS)	2
...	14	C3,4	217941	.. CAPACITOR,ELCTLT 1800 UF 500 VDC CAN 2.52 DIA (460/575 MODELS)	2
.....		217942		.. SPACER,NYLON CAPACITOR	1
.....		217040		.. NUT,NYLON M12 THREAD CAPACITOR MOUNTING	1
...	15	PC7	221047	.. CIRCUIT CARD ASSY,RELINK (200/230/460V model)	1

Item No.	Dia. Mkgs.	Part No.	Description	Quantity
Figure 8-3. Inverter Assy (Fig 8-1 Item 9) (Continued)				
... 16 ...	PC2 ..	221043 ..	CIRCUIT CARD ASSY,INTERCONNECT (200/230/460V model)	1
... 16 ...	PC2 ..	219900 ..	CIRCUIT CARD ASSY,INTERCONNECT (460/575V model)	1
.....	PLG2 ..	168071 ..	HOUSING PLUG PINS+SKTS,(SERVICE KIT)	1
... 17		185835 ..	LABEL,WARNING ELECTRIC SHOCK/EXPLODING PARTS	1
... 18		175140 ..	BRACKET,DI-DT	1
.....		178591 ..	LABEL,CONNECTION DI/DT	1
... 19		181197 ..	GASKET,DI-DT RUBBER	1
... 20 ...	L3,4 ..	175482 ..	COIL,DI/DT	2
... 21		109056 ..	CORE,FERRITE E 2.164 LG X 1.094 HIGH X .826 WIDE	2
... 22 ..	PM1,2 ..	212936 ..	KIT,TRANSISTOR IGBT MODULE	2
... 23 ...	RT2 ..	213029 ..	THERMISTOR,NTC 30K OHM @ 25 DEG C 26IN LEAD 3P	1
... 24		212776 ..	HEAT SINK,POWER MODULE	1
... 25		212753 ..	HEAT SINK,RECT	1
... 26		175255 ..	INSULATOR,RECTIFIER	1
... 27		214537 ..	COVER,ACCESS FAN MOTOR	1
... 28		181853 ..	INSULATOR,SCREW	4
... 29 ..	C2,R1,C5 ..	175194 ..	RESISTOR/CAPACITOR,	1
... 30 ...	RT1 ..	213028 ..	THERMISTOR,NTC 30K OHM @ 25 DEG C 26IN LEAD 2P	1
... 31 ...	D1,2 ..	201531 ..	KIT,DIODE POWER MODULE	2
... 32		199840 ..	BUS BAR,DIODE	2
... 33		179276 ..	BUSHING,SNAP-IN NYL 1.000 ID X 1.375 MTG HOLE CENT	2

+When ordering a component originally displaying a precautionary label, the label should also be ordered.

To maintain the factory original performance of your equipment, use only Manufacturer's Suggested Replacement Parts. Model and serial number required when ordering parts from your local distributor.

☞ Hardware is common and not available unless listed.

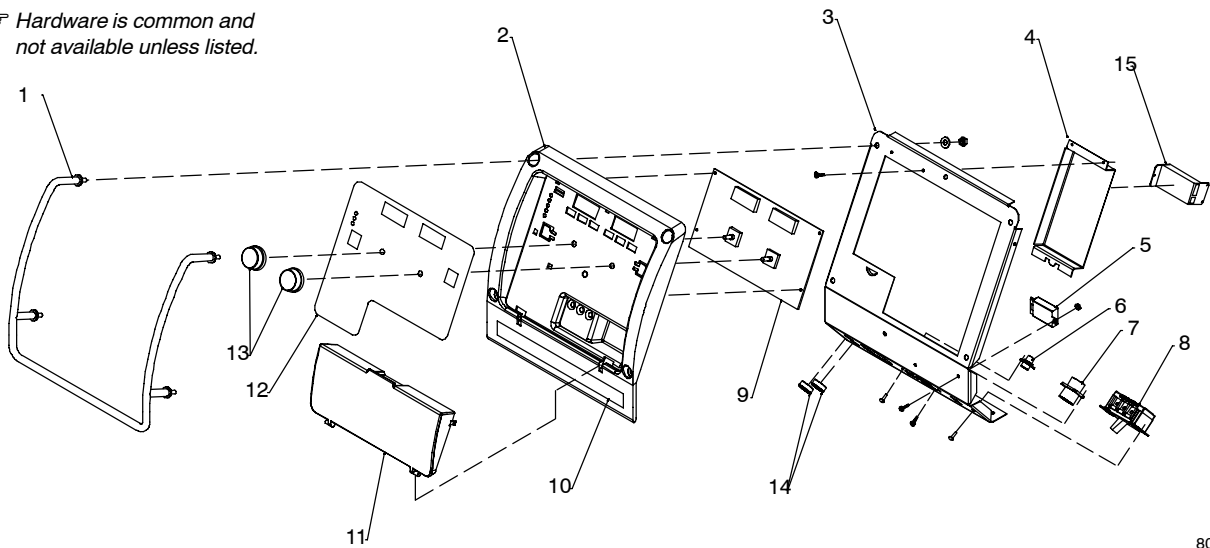

803 547-C

Figure 8-4. Panel, Front w/Components

Item No.	Dia. Mkgs.	Part No.	Description	Quantity
----------	------------	----------	-------------	----------

Figure 8-4. Panel, Front w/Components (Fig 8-1 Item 23)

1		212837	HANDLE	1
2		212845	BEZEL,UPPER	1
3		212819	PANEL,FRONT	1
4		212825	ENCLOSURE,CIRCUIT CARD ASSY	1
5	C8	200953	MODULE,FILTER .1MF 500VDC 10 CKT	1
6		048282	RCPT W/SKTS,(SERVICE KIT)	1
	C9,10	080894	CAPACITOR,CER DISC .01 UF 1000 VDC 20% NYLEZ	2
7		190363	RCPT W/SKTS,(SERVICE KIT)	1
8	S1	128756	SWITCH,TGL 3PST 40A 600VAC SCR TERM WIDE TGL	1
9	PC3	212979	CIRCUIT CARD ASSY,USER INTERFACE	1
	PLG18	115094	HOUSING PLUG+SKTS,(SERVICE KIT)	1
	PLG19	135560	HOUSING RCPT+SKTS,(SERVICE KIT)	1
	PLG28	131055	HOUSING PLUG+SKTS,(SERVICE KIT)	1
10		213936	LABEL,POWER/MIG GUN/SPOOLGUN	1
11		212847	BEZEL,DOOR	1
		218551	INSTRUCTION,FLIPCHART	1
		215232	CLIP,COMPONENT .580H X .715W ADH BACK	2
		213934	LABEL,NAMEPLATE MM350	1
		213935	LABEL,NAMEPLATE MM350P	1
12		212955	LABEL,CONTROLS USER INTERFACE	1
13		213134	KNOB,ENCODER 1.670 DIA X .250 ID PUSH ON W/SPRING	2
14		210398	BUSHING,SNAP-IN	2
15	PC6	220524	MODULE, TACH (350 MODEL ONLY)	1

To maintain the factory original performance of your equipment, use only Manufacturer's Suggested Replacement Parts. Model and serial number required when ordering parts from your local distributor.

☞ Hardware is common and not available unless listed.

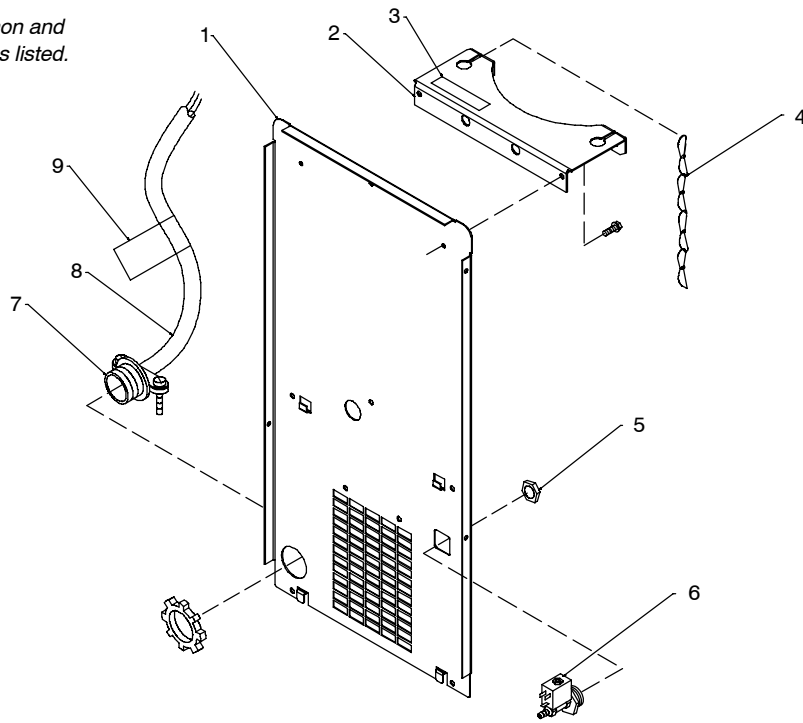

803 549-B

Figure 8-5. Panel, Rear w/Components

Item No.	Dia. Mkgs.	Part No.	Description	Quantity
----------	------------	----------	-------------	----------

Figure 8-5. Panel, Rear w/Components (Fig 8-1 Item 10)

...	1	212820	.. PANEL,REAR	1
...	2	169654	.. BRACKET,SUPPORT TANK	1
...	3	200285	.. LABEL,WARNING CYLINDER MAY EXPLODE IF DAMAGED	1
...	4	188441	.. CHAIN,WELDLESS 2/0 X 31. BRIGHT ZINC PLD	1
...	5	220805	.. NUT, 750-14 NPS 1.48HEX .41H NYL	1
...	6	GS1 219062	.. VALVE, 34VDC 1WAY .750-14 THD 1/8 ORF 100PSI	1
...	7	010467	.. CONN,CLAMP CABLE 1.250	1
...	8	212772	.. CABLE,POWER 10 FT 6IN 6GA 4C (200/230/460V)	1
...		◆213 380	.. PLUG,STR GRD 2P3W 50A 250VAC *6-50P	1
...	8	213018	.. CABLE,POWER 10 FT 6 IN 10GA 4C (460/575V)	1
...		213908	.. PLATE,ADAPTER POWER CORD (575 MODEL ONLY)	1
...	9	214654	.. LABEL,WARNING ELECTRIC SHOCK/INPUT POWER	1

◆OPTIONAL

To maintain the factory original performance of your equipment, use only Manufacturer's Suggested Replacement Parts. Model and serial number required when ordering parts from your local distributor.

**See Table 8-1
Drive Roll & Wire Guide Kits.**

 Hardware is common and not available unless listed.

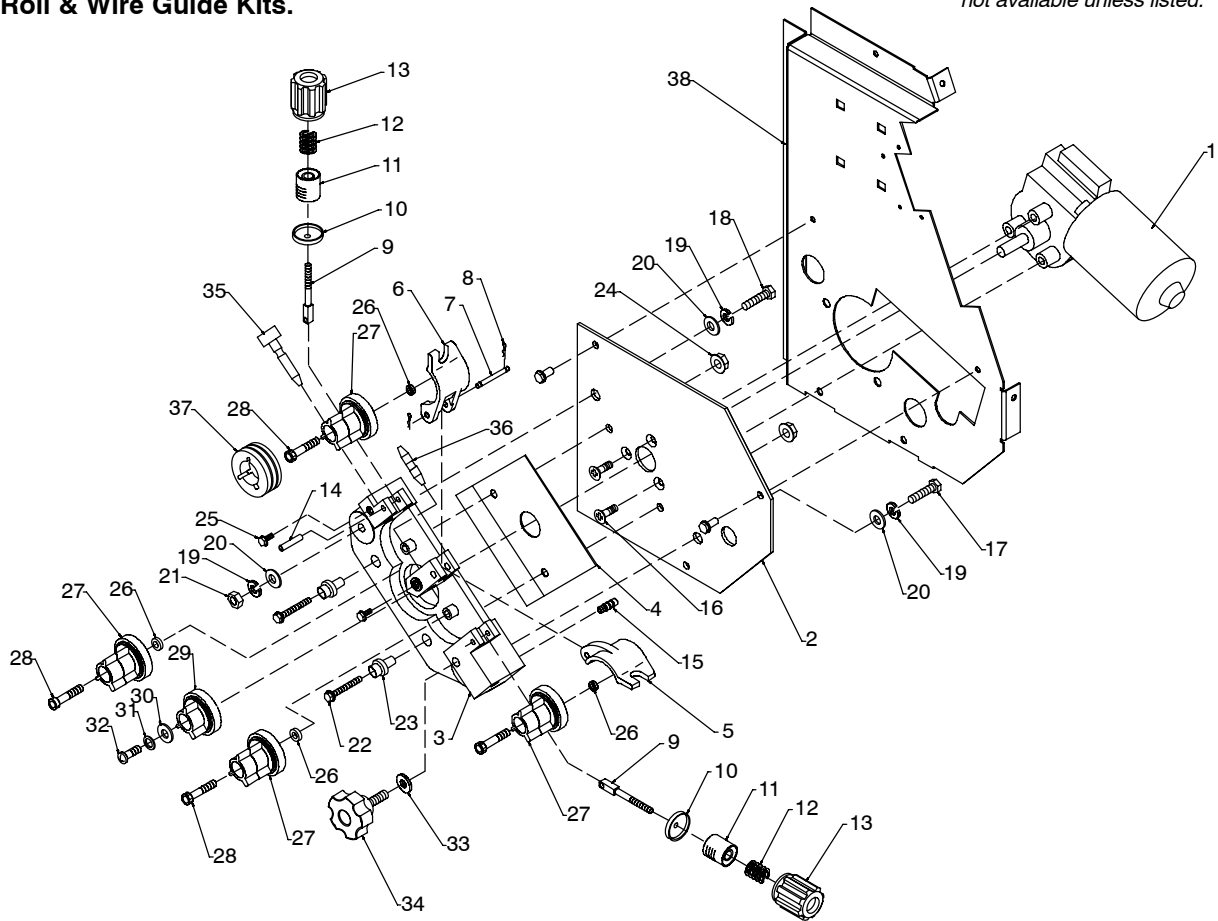

803 548-C

Figure 8-6. Wire Drive Assembly

Item No.	Dia. Mkgs.	Part No.	Description	Quantity
213137 Figure 8-6. Wire Drive Assembly				
1		223541	KIT,MM350 DRIVE MOTOR W/ INSTRUCTIONS	1
2		212844	INSULATOR,DRIVE HOUSING 4 ROLL	1
3		166337	HOUSING,ADAPTER GUN/FEEDER (SALABLE AS 046621)	1
4		194521	INSULATOR,DRIVE ASSY	1
5		166071	LEVER,MTG PRESSURE GEAR	1
6		166338	LEVER,MTG PRESSURE GEAR	1
7		079634	PIN,HINGE	1
8		151828	PIN,COTTER HAIR .042 X .750	2
9		225718	FASTENER,PINNED	2
10		085244	WASHER,CUPPED .328IDX .812ODX16GAX.125 LIP	2
11		196896	CUP,SPRING	2
12		196897	SPRING,CPRSN .695 OD X .095 WIRE X 1.500	2
13		196895	KNOB,TENSION	2
14		010224	PIN,SPRING CS .187 X 1.000	2
15		079633	FTG,HOSE BRS BARBED NIPPLE 3/16 TBG	1
16		195640	SCREW,M 6-1.0X 16 FLATHD-PHL STL PLD	3
17		079240	SCREW,375-16X1.75 HEX HD-PLN STL PLD FULL THRD	1
18		601966	SCREW,375-16X1.25 HEX HD-PLN GR5 PLD	1
19		602213	WASHER,LOCK .380IDX0.691ODX.115T STL PLD SPLIT.375	3
20		602242	WASHER,FLAT .375IDX0.875ODX.083T STL PLD	1
21		601872	NUT, 375-16 .56HEX .34H STL PLD	1
22		108943	SCREW,250-20X1.50 HEXWHD.61D GR5 PLD	2
23		221 654	WASHER,SHLDR INSULATING	2

Item No.	Dia. Mkgs.	Part No.	Description	Quantity
----------	------------	----------	-------------	----------

213137 Figure 8-6. Wire Drive Assembly (Continued)

... 24	089800	NUT, 250-20 .44HEX .22H STL PLD .58D FLANGE DEFOR	2
... 25	602154	SCREW, 250-20X .50 HEXWHD.50D STL PLD SLFFMG TAP-RW	2
... 26	166072	SPACER, GEAR	2
... 27	172075	CARRIER, DRIVE ROLL W/COMPONENTS 24 PITCH	4
... 28	602009	SCREW, 250-20X1.25 SOC HD-HEX GR8 PLN	4
... 29	173618	CARRIER, DRIVE ROLL 10MM SHAFT	1
... 30	195802	WASHER, FLAT .175IDX0.590ODX.040T STL PLD	1
... 31	602241	WASHER, FLAT .281IDX0.625ODX.065T STL PLD ANSI.250	2
... 32	174609	SCREW, M 4- .7X 12 CHEESE HD BLK DIN 84	1
... 33	604538	WASHER, FLAT .344IDX0.688ODX.065T STL PLD ANSI.312	1
... 34	204585	KNOB, FLUTED 1.75 IN W/ .312-18 STUD 1.00 LG	1
... 35	221912	GUIDE, WIRE INLET NYLON .023 - .052	1
... 36	056207	GUIDE, WIRE INTERMEDIATE	1
... 37	189285	ROLL, DRIVE V GROOVE .035-.045 WIRE	4
... 38	212843	HOUSING, ADAPTER DRIVE MOTOR	1

To maintain the factory original performance of your equipment, use only Manufacturer's Suggested Replacement Parts. Model and serial number required when ordering parts from your local distributor.

Table 8-1. Drive Roll And Wire Guide Kits

Note 

Base selection of drive rolls upon the following recommended usages:

- 1 V-Grooved rolls for hard wire.
- 2 U-Grooved rolls for soft and soft shelled cored wires.
- 3 V-Knurled rolls for hard shelled cored wires.
- 4 Drive roll types may be mixed to suit particular requirements (example: V-Knurled roll in combination with U-Grooved).

Wire Diameter			Kit No.	Drive Roll		Wire Guide	
Fraction	Decimal	Metric		Part No.	Type	Inlet	Intermediate
.023/.025 in	.023/.025 in	0.6 mm	087 132	087 130	V-Grooved	056 192	056 206
.030 in	.030 in	0.8 mm	046 780	053 695	V-Grooved	056 192	056 206
.035 in	.035 in	0.9 mm	046 781	053 700	V-Grooved	056 192	056 206
.045 in	.045 in	1.2 mm	046 782	053 697	V-Grooved	056 193	056 207
.052 in	.052 in	1.3 mm	046 783	053 698	V-Grooved	056 193	056 207
1/16 in	.062 in	1.6 mm	046 784	053 699	V-Grooved	056 195	056 209
.035 in	.035 in	0.9 mm	044 750	072 000	U-Grooved	056 192	056 206
.045 in	.045 in	1.2 mm	046 785	053 701	U-Grooved	056 193	056 207
.052 in	.052 in	1.3 mm	046 786	053 702	U-Grooved	056 193	056 207
1/16 in	.062 in	1.6 mm	046 787	053 706	U-Grooved	056 195	056 209
.035 in	.035 in	0.9 mm	046 792	132 958	V-Knurled	056 192	056 206
.045 in	.045 in	1.2 mm	046 793	132 957	V-Knurled	056 193	056 207
.052 in	.052 in	1.3 mm	046 794	132 956	V-Knurled	056 193	056 207
1/16 in	.062 in	1.6 mm	046 795	132 955	V-Knurled	056 195	056 209

Ref. S-0025-D

TRUE BLUE[®]

WARRANTY

Effective January 1, 2006

(Equipment with a serial number preface of "LG" or newer)

This limited warranty supersedes all previous Miller warranties and is exclusive with no other guarantees or warranties expressed or implied.

Warranty Questions?

Call
1-800-4-A-MILLER
for your local
Miller distributor.

Your distributor also gives
you ...

Service

You always get the fast,
reliable response you
need. Most replacement
parts can be in your
hands in 24 hours.

Support

Need fast answers to the
tough welding questions?
Contact your distributor.
The expertise of the
distributor and Miller is
there to help you, every
step of the way.

LIMITED WARRANTY – Subject to the terms and conditions below, Miller Electric Mfg. Co., Appleton, Wisconsin, warrants to its original retail purchaser that new Miller equipment sold after the effective date of this limited warranty is free of defects in material and workmanship at the time it is shipped by Miller. THIS WARRANTY IS EXPRESSLY IN LIEU OF ALL OTHER WARRANTIES, EXPRESS OR IMPLIED, INCLUDING THE WARRANTIES OF MERCHANTABILITY AND FITNESS.

Within the warranty periods listed below, Miller will repair or replace any warranted parts or components that fail due to such defects in material or workmanship. Miller must be notified in writing within thirty (30) days of such defect or failure, at which time Miller will provide instructions on the warranty claim procedures to be followed.

Miller shall honor warranty claims on warranted equipment listed below in the event of such a failure within the warranty time periods. All warranty time periods start on the date that the equipment was delivered to the original retail purchaser, or one year after the equipment is sent to a North American distributor or eighteen months after the equipment is sent to an International distributor.

- 5 Years Parts — 3 Years Labor
 - * Original main power rectifiers
- 3 Years — Parts and Labor
 - * Transformer/Rectifier Power Sources
 - * Plasma Arc Cutting Power Sources
 - * Process Controllers
 - * Semi-Automatic and Automatic Wire Feeders
 - * Inverter Power Sources (Unless Otherwise Stated)
 - * Water Coolant Systems (Integrated)
 - * Intellitig
 - * Engine Driven Welding Generators
(NOTE: Engines are warranted separately by the engine manufacturer.)
- 1 Year — Parts and Labor Unless Specified
 - * Motor Driven Guns (w/exception of Spoolmate Spoolguns)
 - * Positioners and Controllers
 - * Automatic Motion Devices
 - * RFCS Foot Controls
 - * Induction Heating Power Sources, Coolers, and Electronic Controls/Recorders
 - * Water Coolant Systems (Non-Integrated)
 - * Flowgauge and Flowmeter Regulators (No Labor)
 - * HF Units
 - * Grids
 - * Spot Welders
 - * Load Banks
 - * Arc Stud Power Sources & Arc Stud Guns
 - * Racks
 - * Running Gear/Trailers
 - * Plasma Cutting Torches (except APT & SAF Models)
 - * Field Options
(NOTE: Field options are covered under True Blue[®] for the remaining warranty period of the product they are installed in, or for a minimum of one year — whichever is greater.)
 - * Bernard-Branded Mig Guns (No Labor)
 - * Weldcraft-Branded TIG Torches (No Labor)
 - * Subarc Wire Drive Assemblies
- 6 Months — Batteries
- 90 Days — Parts
 - * MIG Guns/TIG Torches and Subarc (SAW) Guns

- * Induction Heating Coils and Blankets, Cables, and Non-Electronic Controls
- * APT & SAF Model Plasma Cutting Torches
- * Remote Controls
- * Accessory (Kits)
- * Replacement Parts (No labor)
- * Spoolmate Spoolguns
- * Canvas Covers

Miller's True Blue[®] Limited Warranty shall not apply to:

- Consumable components; such as contact tips, cutting nozzles, contactors, brushes, slip rings, relays or parts that fail due to normal wear. (Exception: brushes, slip rings, and relays are covered on Bobcat, Trailblazer, and Legend models.)**
- Items furnished by Miller, but manufactured by others, such as engines or trade accessories. These items are covered by the manufacturer's warranty, if any.
- Equipment that has been modified by any party other than Miller, or equipment that has been improperly installed, improperly operated or misused based upon industry standards, or equipment which has not had reasonable and necessary maintenance, or equipment which has been used for operation outside of the specifications for the equipment.

MILLER PRODUCTS ARE INTENDED FOR PURCHASE AND USE BY COMMERCIAL/INDUSTRIAL USERS AND PERSONS TRAINED AND EXPERIENCED IN THE USE AND MAINTENANCE OF WELDING EQUIPMENT.

In the event of a warranty claim covered by this warranty, the exclusive remedies shall be, at Miller's option: (1) repair; or (2) replacement; or, where authorized in writing by Miller in appropriate cases, (3) the reasonable cost of repair or replacement at an authorized Miller service station; or (4) payment of or credit for the purchase price (less reasonable depreciation based upon actual use) upon return of the goods at customer's risk and expense. Miller's option of repair or replacement will be F.O.B., Factory at Appleton, Wisconsin, or F.O.B. at a Miller authorized service facility as determined by Miller. Therefore no compensation or reimbursement for transportation costs of any kind will be allowed.

TO THE EXTENT PERMITTED BY LAW, THE REMEDIES PROVIDED HEREIN ARE THE SOLE AND EXCLUSIVE REMEDIES. IN NO EVENT SHALL MILLER BE LIABLE FOR DIRECT, INDIRECT, SPECIAL, INCIDENTAL OR CONSEQUENTIAL DAMAGES (INCLUDING LOSS OF PROFIT), WHETHER BASED ON CONTRACT, TORT OR ANY OTHER LEGAL THEORY.

ANY EXPRESS WARRANTY NOT PROVIDED HEREIN AND ANY IMPLIED WARRANTY, GUARANTY OR REPRESENTATION AS TO PERFORMANCE, AND ANY REMEDY FOR BREACH OF CONTRACT TORT OR ANY OTHER LEGAL THEORY WHICH, BUT FOR THIS PROVISION, MIGHT ARISE BY IMPLICATION, OPERATION OF LAW, CUSTOM OF TRADE OR COURSE OF DEALING, INCLUDING ANY IMPLIED WARRANTY OF MERCHANTABILITY OR FITNESS FOR PARTICULAR PURPOSE, WITH RESPECT TO ANY AND ALL EQUIPMENT FURNISHED BY MILLER IS EXCLUDED AND DISCLAIMED BY MILLER.

Some states in the U.S.A. do not allow limitations of how long an implied warranty lasts, or the exclusion of incidental, indirect, special or consequential damages, so the above limitation or exclusion may not apply to you. This warranty provides specific legal rights, and other rights may be available, but may vary from state to state.

In Canada, legislation in some provinces provides for certain additional warranties or remedies other than as stated herein, and to the extent that they may not be waived, the limitations and exclusions set out above may not apply. This Limited Warranty provides specific legal rights, and other rights may be available, but may vary from province to province.





Owner's Record

Please complete and retain with your personal records.

Model Name

Serial/Style Number

Purchase Date

(Date which equipment was delivered to original customer.)

Distributor

Address

City

State

Zip



For Service

Contact a DISTRIBUTOR or SERVICE AGENCY near you.

Always provide Model Name and Serial/Style Number.

Contact your Distributor for:

Welding Supplies and Consumables

Options and Accessories

Personal Safety Equipment

Service and Repair

Replacement Parts

Training (Schools, Videos, Books)

Technical Manuals (Servicing Information and Parts)

Circuit Diagrams

Welding Process Handbooks

To locate a Distributor or Service Agency visit www.millerwelds.com or call 1-800-4-A-Miller

Contact the Delivering Carrier to:

File a claim for loss or damage during shipment.

For assistance in filing or settling claims, contact your distributor and/or equipment manufacturer's Transportation Department.

Miller Electric Mfg. Co.

An Illinois Tool Works Company
1635 West Spencer Street
Appleton, WI 54914 USA

International Headquarters—USA

USA Phone: 920-735-4505 Auto-Attended
USA & Canada FAX: 920-735-4134
International FAX: 920-735-4125

European Headquarters – United Kingdom

Phone: 44 (0) 1204-593493
FAX: 44 (0) 1204-598066

www.MillerWelds.com

