

**Strong
Hand
Tools**[®]

Better Tools. Better Price.[®]

WELDING MAGNETS | WELDING CLAMPS
WELDING PLIERS | WELDING TABLES



TAKE CHARGE
of your production time
Reduce lead time, rework and scrap.

www.StrongHandTools.com

2013

BETTER TOOLS**1983**
2013**BETTER PRICE****The Strong Hand Tools® Story...**

We are a company dedicated to helping you work safely, efficiently, comfortably, and cost effectively.

The first time our chief engineer visited a welding shop, he learned that welders very often work with too few tools, or tools that are not adaptable to specific tasks. It occurred to him that with simple changes to traditional tools that have been used in the industrial marketplace for many years we could design clamping tools that set-up more rapidly, are easier to use, and offer the benefits of multi-functionality for use in a variety of workholding applications. We applied that concept to traditional tools such as: Sliding Arm Clamps, Welding Magnetic Squares, Pliers, and Vises.

For over a quarter of a century, we have communicated with welders and craftsmen to develop the innovative, quick-acting clamping tools that allow you to create a "proper" set-up as the foundation for safe, efficient work in welding, assembly, and repair operations. We feel you can't underestimate the importance of holding stock properly, for safety, efficiency, and ideal positioning for worker comfort. When you have those advantages, you can do your best work in the most ideal conditions possible to reduce project lead time and improve work quality. We also set out to offer our innovative tools at affordable prices so that all businesses, to include one man shops, can purchase our tools on sensible budgets, and benefit from the value of Strong Hand Tools in both the purchase price, and the application and function of our tools in frequent use.

As we prepare for the next 30 years, we will continue to study workholding and provide improved methods of clamping and fixturing. We continue to focus on helping you be productive in your work and competitive through cost containment, contributing to your profitability and business growth.

Find your local Strong Hand Tools® Distributor at: www.StrongHandTools.com

**BuildPro™****Modular Welding Tables**www.buildprotables.com**High Precision German Made Welding Tables**www.siegmundtables.com**VALTRA****Operating Accessories & Tooling Components**www.valtrainc.com**Toggle Clamps & Latches**www.goodhandinc.com**Contact Information**

Toll Free 800-989-5244
Phone 562-949-8625
Fax 562-949-4875

Web
www.stronghandtools.com

E-Mail
sales@stronghandtools.com

Headquarters
 7141 Paramount Blvd.
 Pico Rivera, CA 90660 U.S.A.

* Call to request the full line catalogs 

Table of Contents

Welding Clamps



Pliers

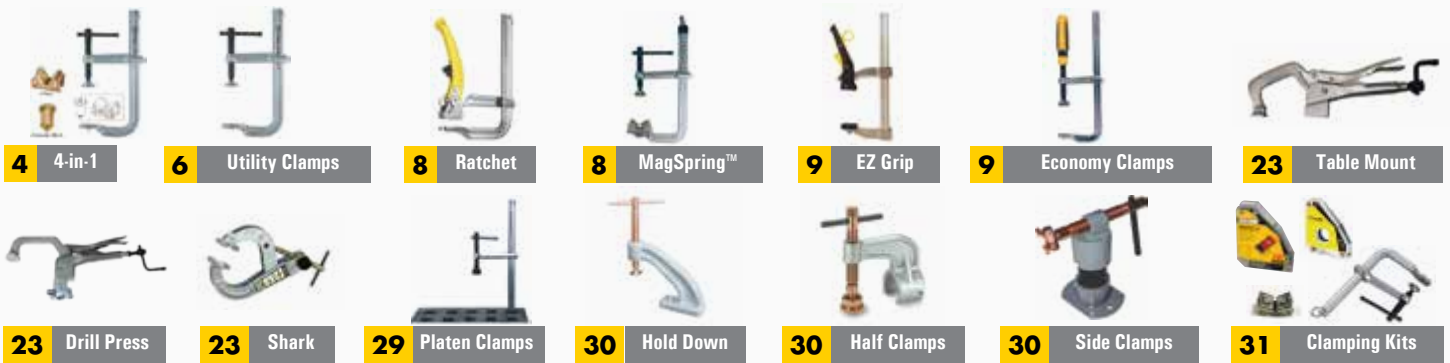
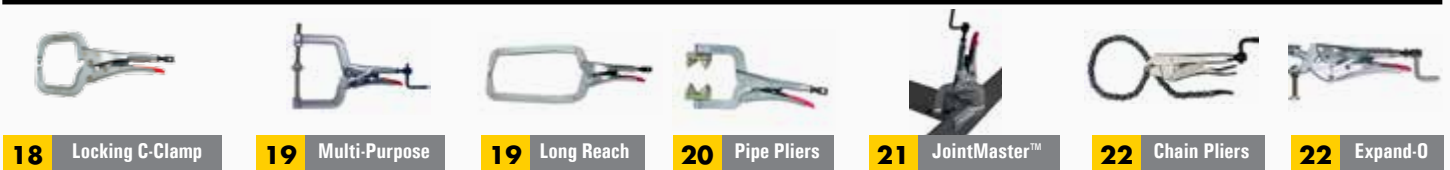

Grounding Pliers & Magnets

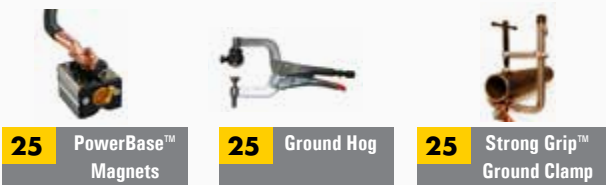

Magnetic Welder Squares



Other Magnetic Products



Levels

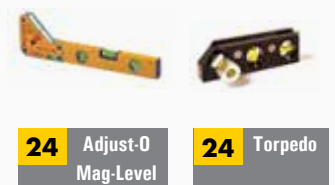

Vises



Special Tools



28 Nomad™ Tables

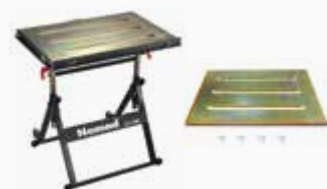

32 Accessories



Other Product Lines

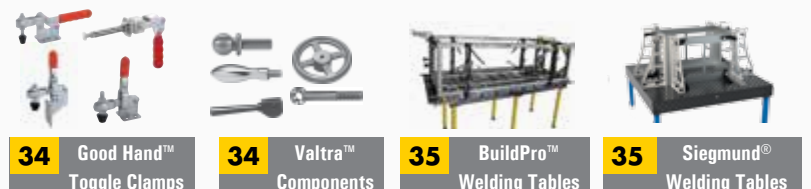

4-IN-1™ Utility Clamping System

BEST SELLERS

The most versatile Sliding Arm Clamps in the market.

ONE Clamp...
FOUR functions.



Replaceable Heavy Duty Pad



Standard Pad



Tapped Hole

For attaching accessories such as the V-Pad or Extender Block.

Removable / Reversible Clamp Arm

The 3 Piece 4-in-1 Clamp Kit includes:

- 4-in-1 Clamp
- Extender Block
- V-Pad.

Extender Block

V-Pad



UD Models:
Remove the Key Ring.



UE,UF,UG,UM Model:
Press the Spring Stop.



UP Models:
Remove the Screw Stop.

PATENTED

The strong, economical 4-IN-1 Utility Clamps adapt to serve four different applications.



1 Standard

Sliding Arm Clamps are 10x faster than a C-Clamp!



2 Pipe

Add the exclusive V-Pad to create a Pipe Clamp!

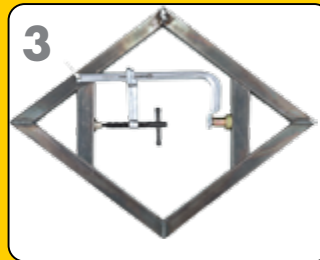

3 Spreader

Reverse the clamp arm and create a Spreader Clamp.

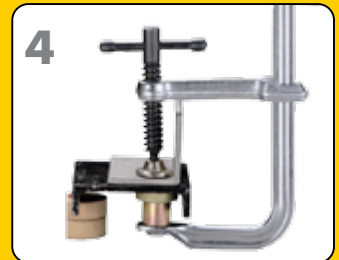

4 Step-Over

Add the Extender Block to create a Step-Over Clamp.



The 4-IN-1 Clamp Kit comes complete with the V-Pad and Extender Block accessories.

4-IN-1 Accessory Pack (Refer to Accessories page 33 for more information)

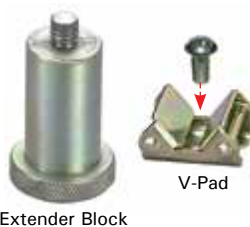

The 4-IN-1 Kit includes a V-Pad, an Extender Block, and a screw.

Part No.	Description	Weight
XMVB XMOVBM	For UM, UP Models (Includes XMV, XMB2)	1.1 LBS 0.5 kg
XFVB XFVBM	For UE, UF, UG Models (Includes XFV, XFB)	0.6 LB 0.3 kg
XDVB XDVBM	For UD Models (Includes XDV, XDB1)	0.3 LB 0.1 kg

4-IN-1™ Utility Clamping System

“ I’ve been able to replace my old set of five C-Clamps with my new 4-in-1 Clamp. ”

- Mark T.



All Strong Hand Tools® Utility Clamps are made of high quality heat treated steel and nickel/chrome plated for strength and durability.

Part No.	Capacity	Throat Depth	Clamping Pressure	Pads	Rail Size	Tapped Hole	Weight
UD45-C3 UD45M-C3	4-1/2" 114 mm	3-1/4" 83 mm	500 LBS 227 kg	Standard	5/8" x 5/16" 16 mm x 8	5/16-18 M8	1.3 LBS 0.6 kg
UD65-C3 UD65M-C3	6-1/2" 165 mm	3-1/4" 83 mm	500 LBS 227 kg	Standard	5/8" x 5/16" 16 mm x 8	5/16-18 M8	1.6 LBS 0.7 kg
UF65-C3 UF65M-C3	6-1/2" 165 mm	4-3/4" 120 mm	1,000 LBS 454 kg	Standard	7/8" x 7/16" 22 mm x 11	3/8-16 M10	2.9 LBS 1.3 kg
UG85-C3 UG85M-C3	8-1/2" 216 mm	4-3/4" 120 mm	1,200 LBS 544 kg	Standard	1" x 15/32" 25 mm x 12	3/8-16 M10	4.1 LBS 1.9 kg
UG125-C3 UG125M-C3	12-1/2" 318 mm	4-3/4" 120 mm	1,200 LBS 544 kg	Standard	1" x 15/32" 25 mm x 12	3/8-16 M10	4.5 LBS 2.1 kg
UG1257-C3 UG1257M-C3	12-1/2" 318 mm	7" *Deep Throat 180 mm	800 LBS 363 kg	Standard	1" x 15/32" 25 mm x 12	3/8-16 M10	6.5 LBS 2.9 kg
UM85P-C3 UM85PM-C3	8-1/2" 216 mm	5-1/2" 140 mm	2,400 LBS 1,089 kg	Standard	1-3/16" x 9/16" 30 mm x 14	3/8-16 M10	6.6 LBS 3.0 kg
UM105P-C3 UM105PM-C3	10-1/2" 267 mm	5-1/2" 140 mm	2,400 LBS 1,089 kg	Standard	1-3/16" x 9/16" 30 mm x 14	3/8-16 M10	7.4 LBS 3.4 kg
UM125-C3 UM125M-C3	12-1/2" 318 mm	5-1/2" 140 mm	2,400 LBS 1,089 kg	Heavy Duty	1-3/16" x 9/16" 30 mm x 14	3/8-16 M10	7.6 LBS 3.5 kg
UM165-C3 UM165M-C3	16-1/2" 419 mm	5-1/2" 140 mm	2,400 LBS 1,089 kg	Heavy Duty	1-3/16" x 9/16" 30 mm x 14	3/8-16 M10	8.7 LBS 4.0 kg
UM205-C3 UM205M-C3	20-1/2" 521 mm	5-1/2" 140 mm	2,400 LBS 1,089 kg	Heavy Duty	1-3/16" x 9/16" 30 mm x 14	3/8-16 M10	9.8 LBS 4.5 kg
UP205-C3 UP205M-C3	20-1/2" 521 mm	7" *Deep Throat 180 mm	4,800 LBS 2,177 kg	Heavy Duty	1-9/16" x 3/4" 40 mm x 19	3/8-16 M10	16.1 LBS 7.3 kg

NEW Large V-Pads

Turn the Heavy Duty "P" Rail Utility Clamps into a pipe clamp with this large V-Pad accessory.
 ["P" Rail size Utility Clamps 1-9/16" x 3/4" (39.6 x 19 mm), clamping pressure 4,800 LBS (2,177 kg)]

Part No.	Tab Hole	Dimension	Weight
XPV	3/8 - 16	4.75" x 1.5" 120.7 x 38.1mm	0.86 LB 0.39 kg

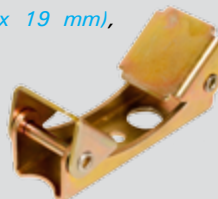

* See Accessories Page 33

Utility Clamps

Utility Clamps set-up 10x faster than a C-Clamp!

PATENTED

Heavy Duty



- Clamping Pressure: 4,800 LBS. (2,177 kg)
- Throat Depth: 7" (180 mm)

* Heavy Duty Replaceable Pads

Part No.	Capacity	Throat Depth	Clamping Pressure	Rail Size	Tapped Hole	Weight
UP125 UP125M	12-1/2" 318 mm	7" 180 mm	4,800 LBS 2,177 kg	1-9/16" x 3/4" 40 mm x 19	3/8-16 M10	12.3 LBS 5.6 kg
UP165 UP165M	16-1/2" 419 mm	7" 180 mm	4,800 LBS 2,177 kg	1-9/16" x 3/4" 40 mm x 19	3/8-16 M10	13.6 LBS 6.2 kg
UP205 UP205M	20-1/2" 521 mm	7" 180 mm	4,800 LBS 2,177 kg	1-9/16" x 3/4" 40 mm x 19	3/8-16 M10	15.0 LBS 6.8 kg
UP245 UP245M	24-1/2" 622 mm	7" 180 mm	4,800 LBS 2,177 kg	1-9/16" x 3/4" 40 mm x 19	3/8-16 M10	16.5 LBS 7.5 kg
UP315 UP315M	31-1/2" 800 mm	7" 180 mm	4,800 LBS 2,177 kg	1-9/16" x 3/4" 40 mm x 19	3/8-16 M10	16.8 LBS 7.6 kg
UP405 UP405M	40-1/2" 1,020 mm	7" 180 mm	4,800 LBS 2,177 kg	1-9/16" x 3/4" 40 mm x 19	3/8-16 M10	22.0 LBS 10.0 kg

Regular Duty w/Heavy Duty Pads



- Clamping Pressure: 2,400 LBS. (1,089 kg)
- Throat Depth: 5-1/2" (140 mm)

* Heavy Duty Replaceable Pads

Part No.	Capacity	Throat Depth	Clamping Pressure	Rail Size	Tapped Hole	Weight
UM65 UM65M	6-1/2" 165 mm	5-1/2" 140 mm	2,400 LBS 1,089 kg	1-3/16" x 9/16" 30 mm x 14	3/8-16 M10	5.4 LBS 2.5 kg
UM85 DM85M	8-1/2" 216 mm	5-1/2" 140 mm	2,400 LBS 1,089 kg	1-3/16" x 9/16" 30 mm x 14	3/8-16 M10	5.9 LBS 2.7 kg
UM105 UM105M	10-1/2" 267 mm	5-1/2" 140 mm	2,400 LBS 1,089 kg	1-3/16" x 9/16" 30 mm x 14	3/8-16 M10	6.4 LBS 2.9 kg
UM125 UM125M	12-1/2" 318 mm	5-1/2" 140 mm	2,400 LBS 1,089 kg	1-3/16" x 9/16" 30 mm x 14	3/8-16 M10	7.0 LBS 3.2 kg
UM165 UM165M	16-1/2" 419 mm	5-1/2" 140 mm	2,400 LBS 1,089 kg	1-3/16" x 9/16" 30 mm x 14	3/8-16 M10	7.6 LBS 3.5 kg
UM205 UM205M	20-1/2" 521 mm	5-1/2" 140 mm	2,400 LBS 1,089 kg	1-3/16" x 9/16" 30 mm x 14	3/8-16 M10	8.7 LBS 4.0 kg
UM315 UM315M	31-1/2" 800 mm	5-1/2" 140 mm	2,400 LBS 1,089 kg	1-3/16" x 9/16" 30 mm x 14	3/8-16 M10	10.6 LBS 4.8 kg
UM420 UM420M	42" 1,067 mm	5-1/2" 140 mm	2,400 LBS 1,089 kg	1-3/16" x 9/16" 30 mm x 14	3/8-16 M10	12.5 LBS 5.7 kg

Regular Duty w/Standard Pads



- Clamping Pressure: 2,400 LBS. (1,089 kg)
- Throat Depth: 5-1/2" (140 mm)
- Standard Pads

Part No.	Capacity	Throat Depth	Clamping Pressure	Rail Size	Tapped Hole	Weight
UM85P UM85PM	8-1/2" 216 mm	5-1/2" 140 mm	2,400 LBS 1,089 kg	1-3/16" x 9/16" 30 mm x 14	3/8-16 M10	5.7 LBS 2.9 kg
UM105P UM105PM	10-1/2" 267 mm	5-1/2" 140 mm	2,400 LBS 1,089 kg	1-3/16" x 9/16" 30 mm x 14	3/8-16 M10	6.3 LBS 3.0 kg
UM125P UM125PM	12-1/2" 318 mm	5-1/2" 140 mm	2,400 LBS 1,089 kg	1-3/16" x 9/16" 30 mm x 14	3/8-16 M10	6.4 LBS 3.1 kg

Utility Clamps

Create your own 4-IN-1 Kit with the 4-IN-1 Accessory Pack!

PATENTED

Light & Medium Duty



- Clamping Pressure: 500 -1,200 LBS. (230 - 544 kg)
- Throat Depth: 3-1/4" - 7" (83 - 180 mm)
- Standard Pads

Part No.	Capacity	Throat Depth	Clamping Pressure	Rail Size	Tapped Hole	Weight
UD45 UD45M	4-1/2" 114 mm	3-1/4" 83 mm	500 LBS 227 kg	5/8" x 5/16" 16 mm x 8	5/16-18 M8	1.0 LB 0.4 kg
UD65 D65M	6-1/2" 165 mm	3-1/4" 83 mm	500 LBS 227 kg	5/8" x 5/16" 16 mm x 8	5/16-18 M8	1.1 LBS 0.5 kg
UD85 UD85M	8-1/2" 216 mm	3-1/4" 83 mm	500 LBS 227 kg	5/8" x 5/16" 16 mm x 8	5/16-18 M8	1.2 LBS 0.6 kg
UE85 UE85M	8-1/2" 216 mm	4" 100 mm	850 LBS 390 kg	25/32" x 3/8" 20 mm x 10	3/8-16 M10	2.3 LBS 1.1 kg
UE125 UE125M	12-1/2" 318 mm	4" 100 mm	850 LBS 390 kg	25/32" x 3/8" 20 mm x 10	3/8-16 M10	2.5 LBS 1.2 kg
UE165 UE165M	16-1/2" 419 mm	4" 100 mm	850 LBS 390 kg	25/32" x 3/8" 20 mm x 10	3/8-16 M10	2.8 LBS 1.3 kg
UE205 UE205M	20-1/2" 521 mm	4" 100 mm	850 LBS 390 kg	25/32" x 3/8" 20 mm x 10	3/8-16 M10	3.0 LBS 1.4 kg
UE245 UE245M	24-1/2" 622 mm	4" 100 mm	850 LBS 390 kg	25/32" x 3/8" 20 mm x 10	3/8-16 M10	3.4 LBS 1.6 kg
UF65 UF65M	6-1/2" 165 mm	4-3/4" 120 mm	1,000 LBS 454 kg	7/8" x 7/16" 22 mm x 11	3/8-16 M10	2.4 LBS 1.1 kg
UF100 UF100M	10" 254 mm	4-3/4" 120 mm	1,000 LBS 454 kg	7/8" x 7/16" 22 mm x 11	3/8-16 M10	2.8 LBS 1.3 kg
UG85 UG85M	8-1/2" 216 mm	4-3/4" 120 mm	1,200 LBS 544 kg	1" x 15/32" 25 mm x 12	3/8-16 M10	3.6 LBS 1.6 kg
UG125 UG125M	12-1/2" 318 mm	4-3/4" 120 mm	1,200 LBS 544 kg	1" x 15/32" 25 mm x 12	3/8-16 M10	4.0 LBS 1.8 kg
UG205 UG205M	20-1/2" 521 mm	4-3/4" 120 mm	1,200 LBS 544 kg	1" x 15/32" 25 mm x 12	3/8-16 M10	4.8 LBS 2.2 kg
UG1257 UG1257M	12-1/2" 318 mm	7" * Deep Throat 180 mm	800 LBS 363 kg	1" x 15/32" 25 mm x 12	3/8-16 M10	6.0 LBS 2.7 kg
UG1657 UG1657M	16-1/2" 419 mm	7" * Deep Throat 180 mm	800 LBS 363 kg	1" x 15/32" 25 mm x 12	3/8-16 M10	6.5 LBS 3.0 kg
UG2057 UG2057M	20-1/2" 521 mm	7" * Deep Throat 180 mm	800 LBS 363 kg	1" x 15/32" 25 mm x 12	3/8-16 M10	7.0 LBS 3.2 kg



J-Clamp Step-Over Series



Part No.	Capacity	Throat Depth (Return)	Clamping Pressure	Rail Size	Tapped Hole	Weight
UD45J UD45JM	4-1/2" 114 mm	3-1/4" (2") 83 mm (50)	500 LBS 227 kg	5/8" x 5/16" 16 mm x 8	3/8-16 M10	1.2 LBS 0.6 kg
UF100J UF100JM	10" 254 mm	4-3/4" (3") 120 mm (75)	1,000 LBS 454 kg	7/8" x 7/16" 22 mm x 11	3/8-16 M10	3.2 LBS 1.5 kg
UG105J UG105JM	10-1/2" 267 mm	4-3/4" (3") 120 mm (75)	1,200 LBS 544 kg	1" x 15/32" 25 mm x 12	3/8-16 M10	5.0 LBS 2.3 kg
*UM125J UM125JM	12-1/2" 318 mm	5-1/2" (4") 140 mm (120)	2,400 LBS 1,089 kg	1-3/16" x 9/16" 30 mm x 14	3/8-16 M10	8.1 LBS 3.7 kg
*UM165J UM165JM	16-1/2" 419 mm	5-1/2" (4") 140 mm (120)	2,400 LBS 1,089 kg	1-3/16" x 9/16" 30 mm x 14	3/8-16 M10	8.5 LBS 4.0 kg
*UM205J UM205JM	20-1/2" 521 mm	5-1/2" (4") 140 mm (120)	2,400 LBS 1,089 kg	1-3/16" x 9/16" 30 mm x 14	3/8-16 M10	9.2 LBS 4.2 kg

*UM Models are equipped with heavy duty pads.

Ratchet Action & MagSpring™ Clamps

Quick-Set Clamps for fast, convenient clamping.

Ratchet Action Utility Clamps

Ratchet mechanism ensures rapid, vibration and torsion resistant clamping.

- Clamping Pressure: 1,000 -1,200 LBS. (460 - 544 kg)
- Throat Depth: 4-3/4" (120 mm)
- Tapped Hole: 3/8-16 (M10)
- Pivoting Contact Plate with 3/8-16 threaded hole

Part No.	Capacity	Clamping Pressure	Rail Size	Weight
UF65R UF65RM	7" 180 mm	1,000 LBS 450 kg	7/8" x 7/16" 22 mm x 11	2.6 LBS 1.2 kg
UF100R UF100RM	10" 254 mm	1,000 LBS 450 kg	7/8" x 7/16" 22 mm x 11	3.0 LBS 1.3 kg
UF100JR UF100JRM	10" 254 mm	1,000 LBS 450 kg	7/8" x 7/16" 22 mm x 11	3.1 LBS 1.4 kg
UG85R UG85RM	8-1/2" 216 mm	1,200 LBS 544 kg	1" x 15/32" 25 mm x 12	3.6 LBS 1.6 kg
UG125R UG125RM	12-1/2" 318 mm	1,200 LBS 544 kg	1" x 15/32" 25 mm x 12	4.8 LBS 2.2 kg
UG205R UG205RM	20-1/2" 521 mm	1,200 LBS 544 kg	1" x 15/32" 25 mm x 12	5.8 LBS 2.6 kg



MagSpring™ Clamps

The spring-loaded, one-handed clamp with quick-set magnetic V-Pad.

Quick & Easy to Use!



Squeeze to Open

Set in Position

Turn to Tighten

- The Spring Loaded Arm allows users to free up one hand to position the workpiece.
- Once positioned, the Adjustable Magnetic V-Pad holds the clamp to the workpiece for tightening.



- Clamping Pressure: 300 - 500 LBS. (140 - 227 kg)
- Throat Depth: 2-1/2" - 3-1/4" (64 - 83 mm)
- Tapped Hole: 1/4-20 (M8)

Spring Loaded Arm

The MagSpring™ holds onto metal, wood and synthetic materials.



Adjustable Magnetic V-Pad

Instantly adjusts for different shapes: round, flat, and angle steel surfaces.



Part No.	Capacity	Throat Depth	Clamping Pressure	Weight
UBV45 UBV45M	3" 75 mm	2-1/2" 64 mm	300 LBS 140 kg	0.8 LB 0.4 kg
UBV65 UBV65M	4-1/2" 115 mm	2-1/2" 64 mm	300 LBS 140 kg	0.9 LB 0.4 kg
UDV45 UDV45M	3" 75 mm	3-1/4" 83 mm	500 LBS 227 kg	1.0 LB 0.5 kg
UDV65 UDV65M	4-1/2" 115 mm	3-1/4" 83 mm	500 LBS 227 kg	1.1 LBS 0.5 kg

EZ Grip Ratchet & Economy Light Duty Clamps

Multi-Purpose Clamps for woodworking and metalworking.

EZ Grip Ratchet Clamp

The lightweight, Quick-Set Ratchet Clamp

Pull Finger-Loop

For one finger locking.

Press Release Trigger

Non Marring Surfaces

Protects work surfaces

Step Over



Included accessories:



Non Marring Slip On Pads
Neoprene cap



2" (50 mm) Extender Block
Part No: VER01
For Step-Over applications.
Snaps into jaw hole.

- Ideal for firm, no-mar holding of aluminum, wood and non-metallic materials.
- Hold delicate materials securely in drilling, cutting, assembly, or bending applications. Great for assembly work.
- The lightweight clamp is easy to handle, easy to set, lock, and release.
- Max. Clamping Pressure: 250 LBS (120 kg)
- Throat Depth: 3" (76 mm)

Part No.	Capacity	Rail Size	Weight
VER45	4-1/2" 114 mm	3/4" x 1/4" 19 mm x 6	0.6 LB 0.3 kg
VER85	8-1/2" 216 mm	3/4" x 1/4" 19 mm x 6	0.9 LB 0.4 kg
VER125	12-1/2" 318 mm	3/4" x 1/4" 19 mm x 6	1.3 LBS 0.6 kg
VER165	16-1/2" 419 mm	3/4" x 1/4" 19 mm x 6	1.6 LBS 0.7 kg

Economy Light Duty

- Clamping Pressure: 300 LBS. (140 kg)
- Throat Depth: 2-1/2" (65 mm)
- Standard Pads



Part No.	Capacity	Rail Size	Tapped Hole	Weight
UB45A UB45AM	4-1/2" 114 mm	1/2" x 1/4" 13 mm x 6	1/4-20 M6	0.8 LB 0.4 kg
UB65A UB65AM	6-1/2" 165 mm	1/2" x 1/4" 13 mm x 6	1/4-20 M6	0.9 LB 0.4 kg
UB85A UB85AM	8-1/2" 216 mm	1/2" x 1/4" 13 mm x 6	1/4-20 M6	1.0 LB 0.5 kg
UB125A UB125AM	12-1/2" 318 mm	1/2" x 1/4" 13 mm x 6	1/4-20 M6	1.2 LBS 0.5 kg
UB165A UB165AM	16-1/2" 419 mm	1/2" x 1/4" 13 mm x 6	1/4-20 M6	1.3 LBS 0.6 kg
UB205A UB205AM	20-1/2" 521 mm	1/2" x 1/4" 13 mm x 6	1/4-20 M6	1.4 LBS 0.6 kg

Non-Marring Rubber Pads



Slip-on top and bottom lamp jaws to protect wood, metal, or synthetic work surfaces. Each package contains 2 sets.

Part No.	Description	Weight
XBP2	For UB model clamps	0.1 LB / 0.1 kg
XDP2	For UD model clamps	0.1 LB / 0.1 kg
XEP2	For UE model clamps	0.2 LB / 0.1 kg
XFP2	For UF model clamps	0.2 LB / 0.1 kg
XGP2	For UG model clamps	0.2 LB / 0.1 kg

Adjust-O™ Magnet Squares

The original magnet squares featuring On/Off switches.

Patent No.
US 7,009,480 B2

Adjust-O™ Magnet Squares

The fast & easy way to hold metal workpieces at 45° & 90°.

- Turn the magnet Off when setting up, turn On when you're ready to work. Fast and safe set-up!
- Ideal for round and square tubing, angle, and flat stock.
- Easy to clean. Simply turn Off and wipe.



Made with strong, durable rare earth magnets.
Fully enclosed for easier cleaning.

The On/Off switch





MSA45
45°, 90°



HEAVY DUTY
MSA48-HD
45°, 90°



HEAVY DUTY
MSA53-HD
Multi-Angles: 30°, 45°, 60°, 90°

Part No.	Max. Pull Force	Dimension	Weight
MSA45	65 LBS 30 kg	4-3/8" x 3-3/4" x 1" 111 mm x 95 x 25	1.0 LB 0.5 kg
MSA46-HD	90 LBS 40 kg	4-3/8" x 3-3/4" x 1-1/8" 111 mm x 95 x 29	1.5 LBS 0.7 kg
MSA47	75 LBS 35 kg	6" x 5-1/8" x 1-1/4" 152 mm x 130 x 32	2.2 LBS 1.0 kg
MSA48-HD	160 LBS 75 kg	6" x 5-1/8" x 1-3/8" 152 mm x 130 x 35	3.0 LBS 1.4 kg
MSA53-HD	140 LBS 65 kg	6" x 5-1/8" x 1-3/8" 152 mm x 130 x 35	3.0 LBS 1.4 kg

*Magnetic force is based on the longest side of Magnet with 3/8" thick steel.

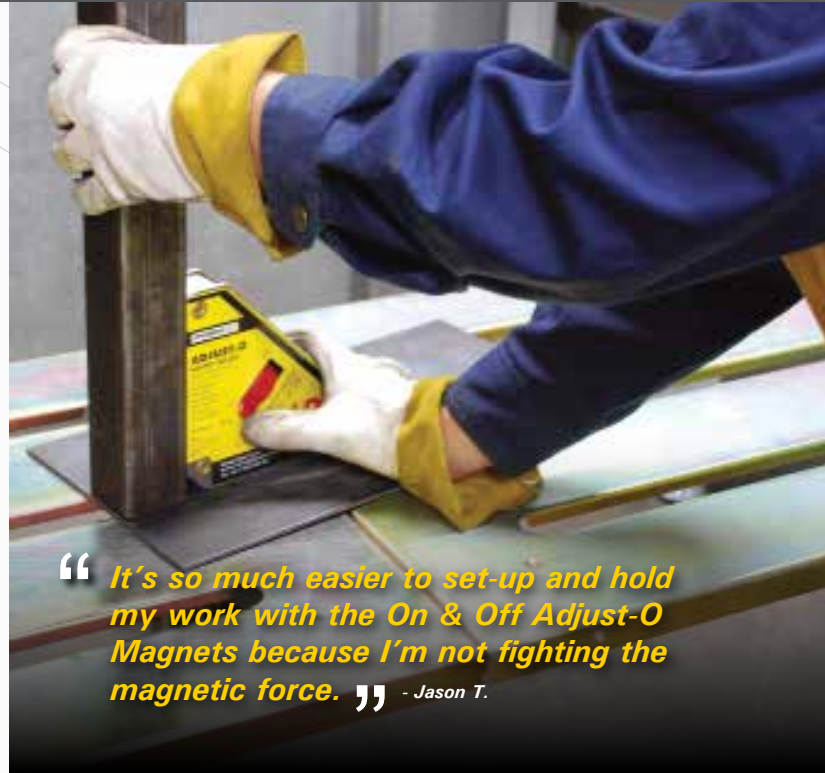

“It's so much easier to set-up and hold my work with the On & Off Adjust-O Magnets because I'm not fighting the magnetic force.” - Jason T.

3rd-Axis Magnetic Posts for Adjust-O™ Magnet Squares

- Quickly and easily set-up 3-Axis workpieces.
- Use on either side of the magnet squares.
- Fits all MSA Adjust-O™ Magnet Squares.

MXE13



Holding a 3-Axis workpiece.

Part No.	Description	Max. Pull Force	Weight
MXE13	3 Posts per set	16 LBS 7 kg	0.2 LB 0.1 kg

*Magnetic force is based on the longest side of Magnet with 3/8" thick steel.

Adjust-O™ Angle Magnet Squares

Angle magnet squares with the convenience of On/Off switches.

PATENTED

Adjust-O™ Angle Magnet

- Adjustable from 30° - 275° with two On/Off switches.
- Precision machined flat surfaces and nickel/chrome body.
- V-Groove surfaces securely hold round and square tubing, angle, and flat stock.

MAV120

Machined V-Groove
For holding round & flat stock.

30° - 275°

Adjustable Handle
For setting & locking the desired angle.

2 x On/Off Switch



Part No.	Angles	Max. Pull Force	Dimension	Weight
MAV120	30° - 275°	110 LBS 50 kg	7-3/4" x 7-3/4" x 3-3/4" 197 mm x 197 x 95	5.3 LBS 2.4 kg

*Magnetic force is based on the 3/8" thick steel.

Adjust-O™ 90° Dual Switch Magnet Squares

For professional jobs that demand strong hold down forces.
Hold flat and round metal work pieces.

- Two On/Off switches for independent operation.
- Turn the magnets Off when setting up, turn On when you're ready to work. Easy and safe set-up!
- Precision machined flat and V-surfaces are ideal for round and square tubing, angle, and flat stock.
- Choose from 120 - 265 LBS (55 - 120 kg) pull force.

On/Off Switch

MS2-80
120 LBS (55 kg) Max. Pull force

MS2-90
265 LBS (120 kg) Max. pull force



Part No.	Max. Pull Force	Dimension	Weight
MS2-80	120 LBS 55 kg	6" x 6" x 1-1/2" 152 mm x 152 x 38	2.7 LBS 1.2 kg
MS2-90	265 LBS 120 kg	7-3/4" x 7-3/4" x 1-7/8" 197 mm x 197 x 48	6.0 LBS 2.7 kg

*Magnetic force is based on the 3/8" thick steel.

Multi-Angle Magnet Squares

Set-up 2 or 3-Axis stock at multiple angles.

PATENTED

XYZ Magnet Squares

- Quickly and easily set-up 2 or 3-Axis workpieces.
- Re-position, while holding. Tap or slide workpieces to fix positioning, without removing the Magnet!
- New Magnetic Face Plate features two rare earth disc magnets for 3rd axis holding. Turn the Magnetic Face Plate with your finger to desired position. Quickly snap together 2 or 3 axis set-ups for tack welding.

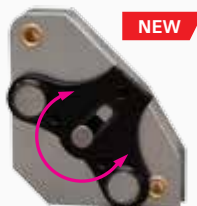

Model MS350 shown

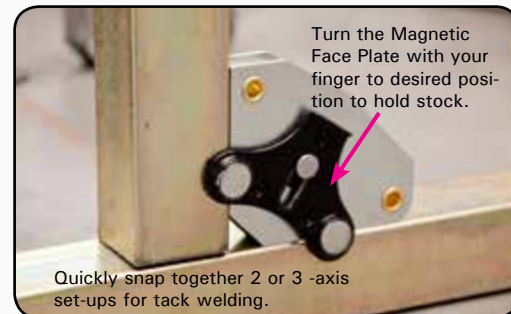
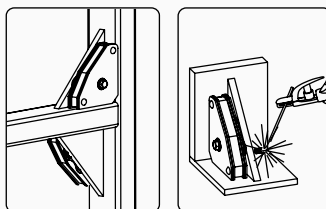
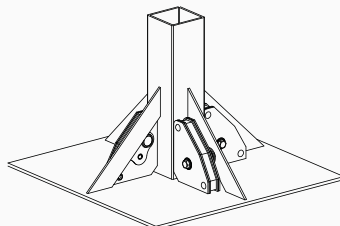

Turn the Magnetic Face Plate with your finger to desired position to hold stock.

Quickly snap together 2 or 3 axis set-ups for tack welding.

Interchangeable Magnetic Plate

Place on either side of the XYZ Magnet.

(Max. Pull Force: 6 LBS / 3 kg)



The 3-Axis Magnetic Plate features two rare earth disc magnets for 3rd axis holding.

Part No.	Description	Max. Pull Force	Dimension	Weight
MST348	Twin Pack	25 LBS 10 kg	2-5/16" x 2" x 7/8" 59 mm x 50 x 22	0.6 LB 0.3 kg
MS350	Ea.	30 LBS 13.6 kg	3-2/5" x 3" x 5/8" 86 mm x 75 x 16	0.75 LB 0.34 kg

*Magnetic force is based on the longest side of Magnet with 3/8" thick steel.

Standard Magnet Squares



MS346AT
Mini Multi Angle

MS350A
Multi-Angle

MS45
45°, 90°

MS60
60°, 90°

MS346C
Multi-Angle

Holding at multiple angles while soldering, brazing, and welding at 30°, 45°, 60°, and 90°.

- The compact size of the Mini Magnets makes it easy to pack, store, and carry for use anywhere!
- Accurate 30°, 45°, 60°, 90° angles.
- Center hole for easy handling.

Part No.	Angles	Max. Pull Force	Dimension	Weight
MS346AT Twin Pack	30°, 60° 45°, 90°	25 LBS 10 kg	2-5/16" x 2" x 5/8" 59 mm x 50 x 16	0.6 LB 0.3 kg
MS346AK 6-Pack	30°, 60° 45°, 90°	25 LBS 10 kg	2-5/16" x 2" x 5/8" 59 mm x 50 x 16	1.7 LBS 0.8 kg
MS350A	30°, 60° 45°, 90°	30 LBS 13.6 kg	3-2/5" x 2-15/16" x 5/8" 86 mm x 75 x 16	0.66 LB 0.3 kg
MS45	45° - 90°	65 LBS 30 kg	4-3/8" x 3-3/4" x 3/4" 111 mm x 95 x 19	1.0 LB 0.5 kg
MS60	60° - 90°	55 LBS 25 kg	4-3/8" x 3-3/4" x 3/4" 111 mm x 95 x 19	1.0 LB 0.5 kg
MS346C	30°, 60° 45°, 90°	85 LBS 40 kg	5-1/2" x 4-3/8" x 3/4" 140 mm x 111 x 19	1.0 LB 0.5 kg

*Magnetic force is based on the longest side of Magnet with 3/8" thick steel.

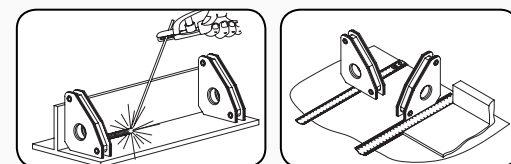
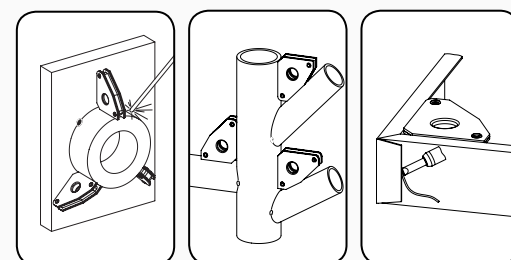

MagTab™ (DUO) & Special Tools

Time saving magnetic tools for use in the shop & in the field.

PATENTED

UNIQUE MagTab™ & New MagTab™ AL

The better, faster way to hold tabs in place for tack welding!

- Hold tabs, or any small metal pieces, parallel or perpendicular to the substructure.
- The Adjustable Magnetic V-shape base adjusts for different shapes: round, flat, angle metal surfaces.

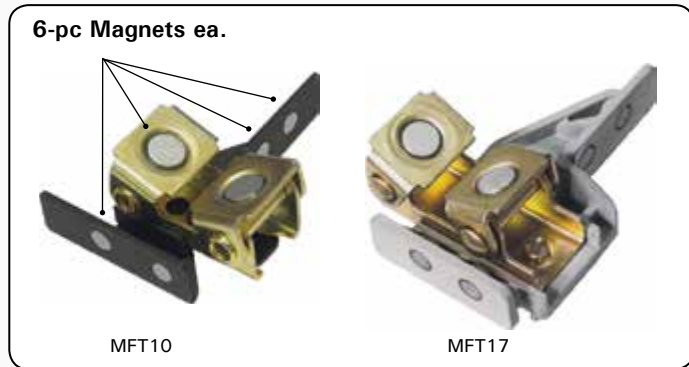

Perpendicular tab

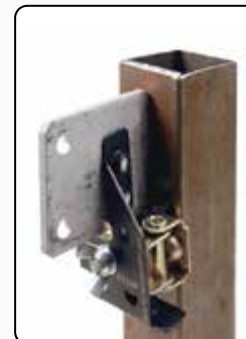

Parallel Tab



Positioning handle

Part No.	Dimension	Max. Pull Force	Weight
MFT10	4" x 3" x 1-1/4" 100 mm x 76 x 32	18 LBS 8 kg	0.5 LB 0.2 kg
MFT17	4-3/8" x 3" x 1-1/2" 111 mm x 73 x 38	18 LBS 8 kg	0.6 LB 0.3 kg

*Magnetic force is based on the 3/8" thick steel.

MagTab™ AL

- Made of machined, die cast aluminum for greater accuracy.
- Two mounting holes provide a wider range of adjustment, and allow for side mounting on pipes and tubes up to 3" in dia.



NEW MagTab DUO

No clamping edges required! Clamp anywhere on flat, round or angled surfaces!

Position and hold pipes, tubes or plates at two points, on ONE side of your workpiece, leaving ample space on the other side for welding.

Part No.	Description	Weight
MFT12	Symmetric MagTabs Twin Pack of MFT10	1 LB 0.45 kg



NEW Magnetic Nut & Bolt Holders (Patents Pending)

Hold Nuts and Bolts in place before tightening.

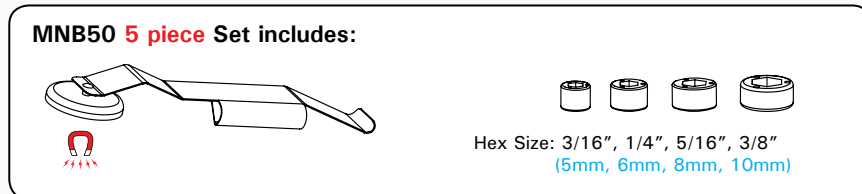

- Slide Magnetic Ring on Hex Wrench Tip to steady, pickup, and hold nuts and bolts in place while you work.
- Clip Magnetic Wrench Attachment on any size wrench to hold nuts and bolts in place before tightening.
- No more fumbling while trying to hold small parts!
- Ideal when working in tight spaces and hard to reach areas!
- Total Weight: 0.08 LB (0.04 kg)

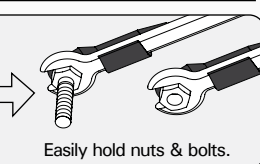
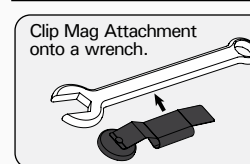
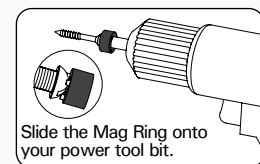
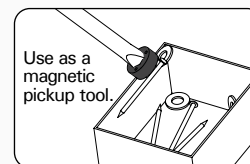
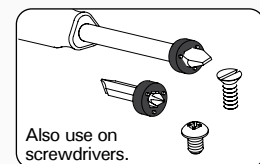
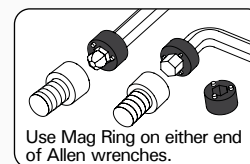

Corner Magnets & Mag. V-Pads

Time saving magnetic tools for use in the shop & in the field.

Corner Magnets

- Create 90° corners by holding from the outside, providing you with an unobstructed area for inside tack welds.
- One side corner "relief" provides clearance for tall lips.
- Use the outer edges of the Corner Magnet for setting up materials at 60°.

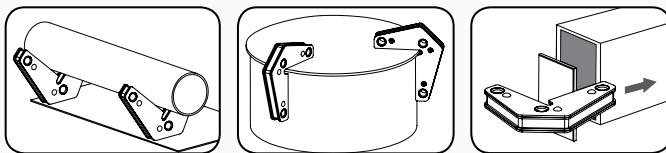

Part No.	Description	Dimension	Max. Pull Force	Weight
MST327	Twin Pack 90° & 60°	3-1/4" x 3-3/4" x 5/8" 83 mm x 95 x 16	30 LBS 14 kg	0.9 LB 0.4 kg

*Magnetic force is based on the longest side of Magnet with 3/8" thick steel.

Adjustable Magnetic V-Pads

Light duty & tight spot holding! Build, Hold, and Position Steel.

- Hold and position round, flat, and square parts in light duty substructure applications!
- Each V-Pad contains 4 rare-earth magnets.

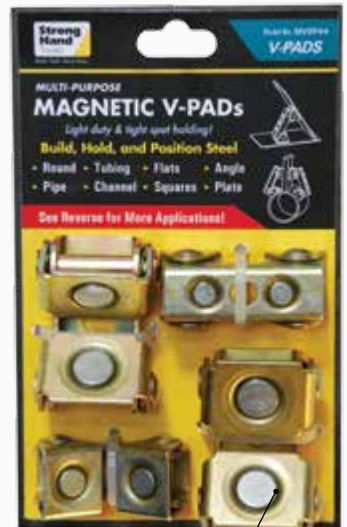
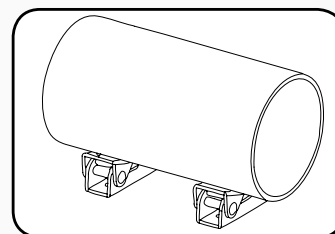
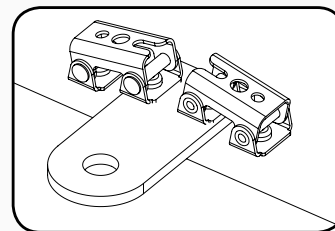

Rare Earth Magnets

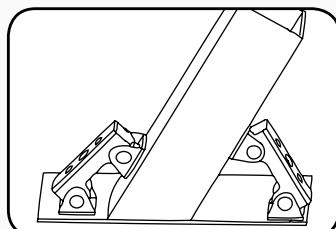
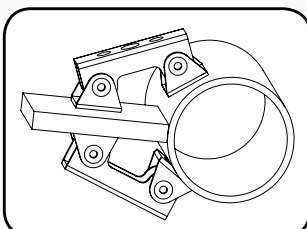

Part No.	Description	Max. Pull Force	Weight
MVDF44	2 Regular V-Pads (XDV4) & 2 Large V-Pads (XVF4)	18 LBS 8 kg	0.9 LB 0.4 kg

*Magnetic force is based on the 3/8" thick steel.

Snake Magnets & Panel Clamps

Time saving magnetic tools for use in the shop & in the field.

Snake Magnets

The Third Hand - *Holds, Bends, Twists*

- Comes complete with 2 magnetic pads and 1 spring clamp.
- MFC312 has a 12" (305 mm) cable with 2 magnetic V-pads.
- MFC318 has a 18" (450 mm) cable with 2 flat magnetic pads.

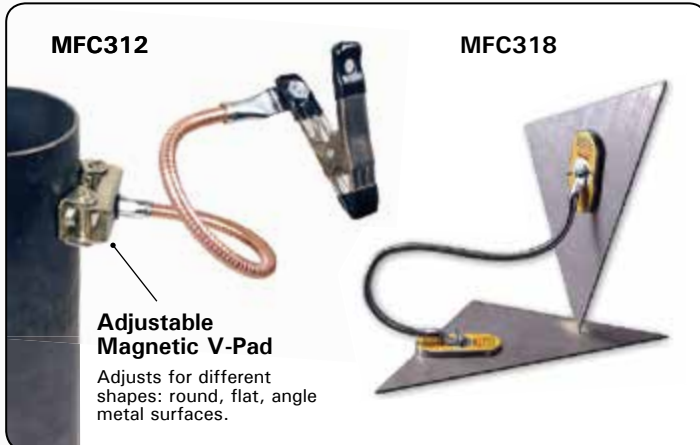

Part No.	Description	Max. Pull Force	Weight
MFC312	12" (305 mm) flex cable, 1 clamp, 2 Adjustable Magnetic V-pads	18 LBS 8 kg	1.0 LB 0.5 kg
MFC318	18" (450 mm) flex cable, 1 clamp, 2 flat Magnetic Pads	20 LBS 10 kg	1.4 LBS 0.6 kg

*Magnetic force is based on the 3/8" thick steel.

When using the versatile Magnetic V-Pads, the Snake Magnet can hold against flat, round, square or angled surfaces.



Spring Clamp can be used as the third hand to hold tools.



The Snake Magnet gives you the flexibility to hold stock at odd angles.



NEW Panel Clamps

Magnets hold clamp parts and panels together!

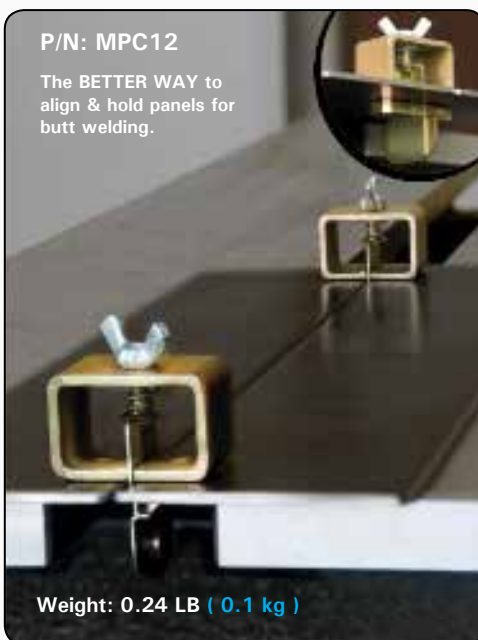

- Magnets in the Keeper Plate and the clamp body hold your panels in position for a speedier, and more efficient setup. NO MORE fumbling while trying to hold the panels and the clamps!
- Turn the spring-loaded screw to adjust the opening to accept panels of different thicknesses [Max. 0.2" (5 mm)].
- Wider-than-standard clamp body holds your panels flatter, for a more precise setup. Panels will not spin out of alignment.
- A magnet in the Keeper Plate holds your panels together even when used in the vertical position.
- Consider our Sheet Metal Magnet (Part No. MCB82) for top-side alignment of panels.

P/N: MPC12
Twin Pack

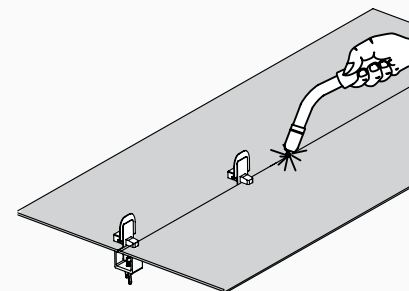
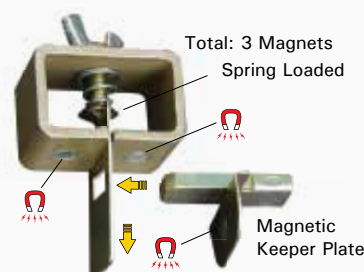

Gusset Plate Magnet & MagBrace

Time saving magnetic tools for use in the shop & in the field.

NEW Gusset Plate Magnet

Unique! Developed by Customer Demand for quick parallel plane alignment, locating, and clamping of Gussets, Base Plates, and Panels.

This low-profile Gusset Plate Magnet provides the unique function of holding stock securely at 3 points directly on the surface area of Gussets, Base Plates, and Panels for locating and clamping, while leaving ample space for tack welding.

Four rare earth disc magnets set in the magnet face hold the Gusset Plate Magnet against your frame or substructure with direct, even clamping pressure for a fast, accurate and convenient setup. Three Adjustable 1-1/2" Magnetic Hex Bolts protrude from the magnet face and can be pre-set to the correct depth to securely position the gusset panel in a precise location for tack welding.

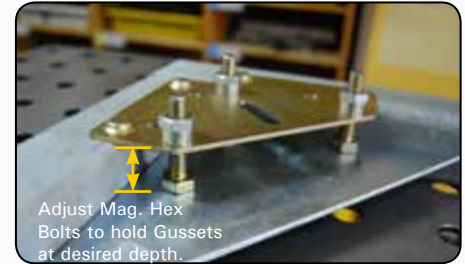
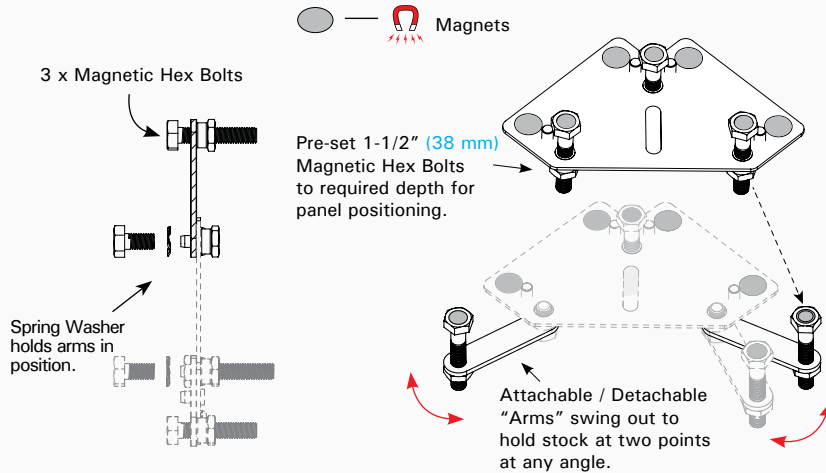

Part No.	Dimension	Arm Length	Magnets	Weight
MGH20	4.5" x 4.5" 114 mm x 114	2.2" 56 mm	7pc	0.6 LB 0.27 kg

NEW MagBrace

P/N: UBB65

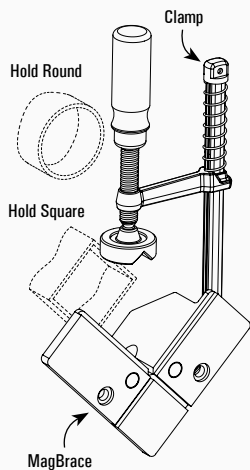

Position a single metal piece, or 2-axis stock, at 90° on round, square, or angled structures before tack welding. The MagBrace creates a "rest" for secure holding and positioning of stock. Magnets on the face of the 1.8" "rest" provide light duty holding of stock. Made of machined aluminum die casting. Choose from MagBrace only (Mount with your own clamp) or MagBrace & Clamp Set.

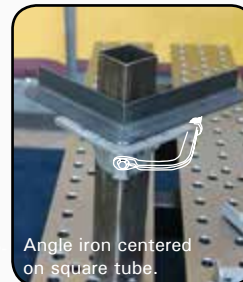
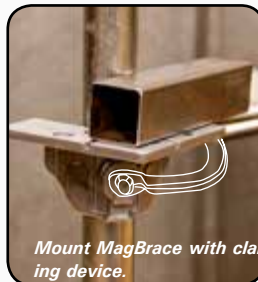

P/N: MX50

Magnets

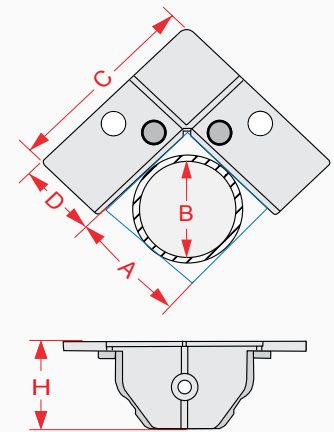

Part No.	Description	A (max square)	B (max Ø)	C	D	H	Weight	
MX50	MagBrace with 2 magnets	3" x 3" 76 mm x 76	2.75" 70 mm	4.5" 114 mm	1.8" 46 mm	2.4" 61 mm	0.66 LB 0.3 kg	
UBB65	MagBrace mounted on clamp w/ Spring-loaded arm	MagBrace same as above						1.5 LBS 0.7 kg

Sheet Metal Magnets & Hand Rest Glide Kit

New tools for sheet metal holding and welder comfort.

NEW Sheet Metal Magnets

Hold sheet metal and automotive metal panels firmly in a positive location for cutting, welding, tacking, painting and repair operations.

Rare earth disc magnets in the magnetic plate have superior gripping power. Use horizontally or vertically. The strong, generously sized plastic handle makes placing, moving, and removing the Sheet Metal Magnets fast and easy.

Part No.	Description	Weight	Max. Pull Force
MCB82	Sheet Metal Magnets (Twin Pack)	1.2 LBS 0.54 kg	100 LBS (45 kg)
MCB802	Replaceable Rubber Pad x 10 pcs.	--	--
MCB84	2 pcs. Sheet Metal Magnets, 1 pc. Mountable / Magnetic Wall Caddy, 3 pcs. Plastic Hold Down Straps.	2 LBS 0.9 kg	--

*Magnetic force is based on the 3/8" thick steel.

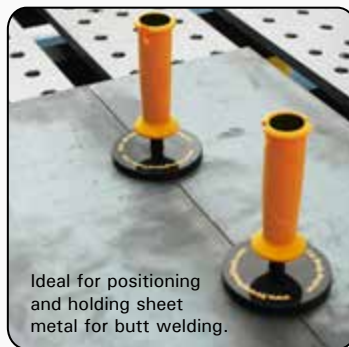

NEW Hand Rest Glide Kit

Unique and Very Practical! This Hand Rest glides smoothly on cut-to-length angle iron allowing you to steady your wrist. Reduce hand and shoulder stress and fatigue. Safely keep your hand and arm elevated. Powder coated steel rest plate swivels 360° on the base for support in a full arc.

Kit includes Hand Rest, and 2 Magnetic Mounting Bases. Total weight: 1.5 LBS (0.68kg). *Angle Iron NOT provided.*

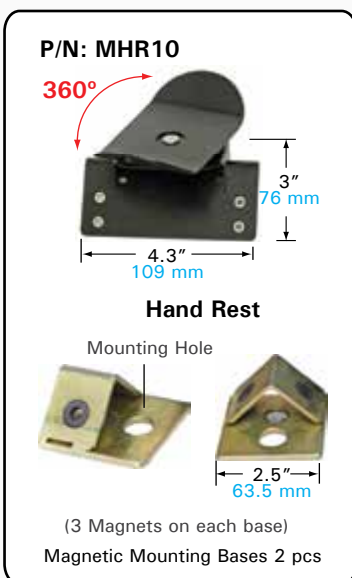

Hand Rest Glide Kit Assembly Example:

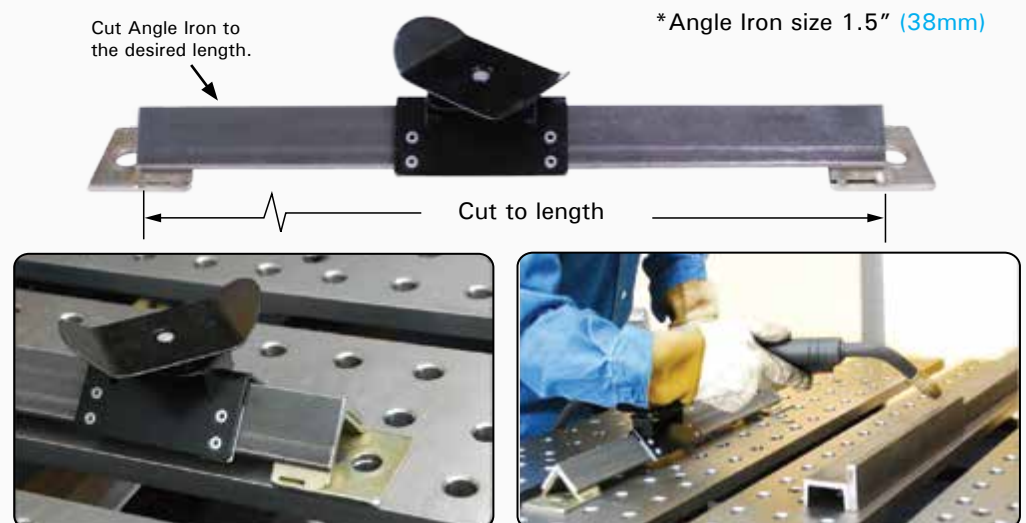

Improved Locking C-Clamps

Improved features for professionals and Do-It-Yourselfers.

Made of heat treated steel and nickel/chrome plated for strength and durability. Updated features help you work quickly, safely and efficiently.

Round Tip Model PR115

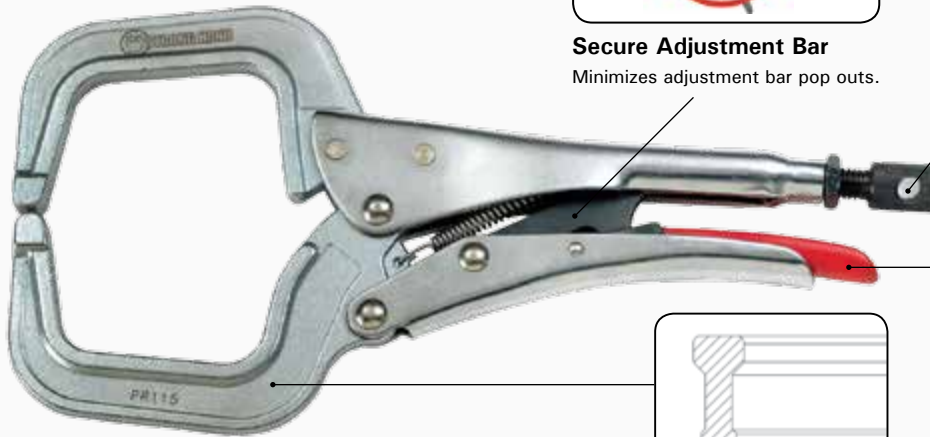

Secure Adjustment Bar
Minimizes adjustment bar pop outs.

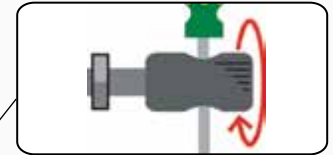

Adjustment Screw
Large adjustment screw with a hole for easy torque.



Single Hand Release Handle
Vinyl coated release handles made for comfort and ease.

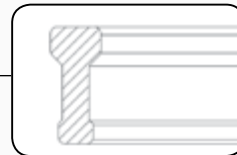

Cross Section
Made of heat treated steel and nickel/chrome plated for strength and durability.



Swivel Pad Models



PR115S



PR18S

Add the crank handle accessory to the Improved Locking C-Clamps to:

- Increase torque.
- Pre-set the Plier opening for repetitious clamping applications.
- Loosen the Plier before unlocking.

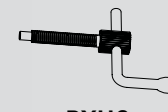

PXH6

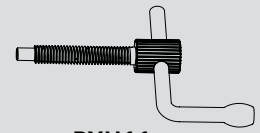

PXH11

Optional Crank Handle:

Can be purchased separately. (See accessories page)

	Part No.	OAL	Throat Depth	Opening	Weight
Round Tip	PR6	6-1/2" 165 mm	1-13/16" 46 mm	2-3/16" 56 mm	0.5 LB 0.2 kg
	PR115	11" 280 mm	3-1/4" 83 mm	4" 100 mm	2.0 LBS 0.9 kg
	PR18	18" 450 mm	10" 254 mm	4-1/2" 114 mm	3.0 LBS 1.4 kg
Swivel Pad	PR6S	6-1/2" 165 mm	1-13/16" 46 mm	2-3/16" 56 mm	0.6 LB 0.3 kg
	PR115S	11" 280 mm	3-1/4" 83 mm	4" 100 mm	2.2 LBS 1.0 kg
	PR18S	18" 450 mm	10" 254 mm	4-1/2" 114 mm	3.1 LBS 1.4 kg

Part No.	For Pliers
PXH6	For 6" (152 mm), 8-1/2" (216 mm) Pliers
PXH11	For 11" (280 mm) Pliers

Multi-Purpose Pliers

Swivel and fixed head spindles for flexibility in clamping.

Multi-Purpose Pliers

One swivel pad spindle and a fixed head spindle for flexible clamping. Threaded jaw holes allow addition of accessories.

PG622

Swivel Pad
Fixed Spindle



PG134



Part No.	OAL	Throat Depth	Opening	Thread	Weight
PG622	6" 150 mm	2" 50 mm	2-1/2" 64 mm	M8	0.5 LB 0.2 kg
PG634	8-1/2" 216 mm	3" 76 mm	4" 100 mm	M8	1.0 LB 0.5 kg
PG114 PG114M	11" 280 mm	3-1/2" 89 mm	4" 100 mm	3/8-16 M10	3.0 LBS 1.4 kg
PG134 PG134M	13" 330 mm	5-1/2" 140 mm	4" 100 mm	3/8-16 M10	0.6 LB 0.3 kg

Adjustable Reach and Long Reach Multi-Purpose Pliers

Thread : 3/8-16 (M10) | Opening : 4" (100 mm)

PGA20

Adjustable Reach

PATENTED



PGA20S

Adjustable Reach
with Fixed Jaw



Part No.	OAL	Throat Depth	Weight
PGA20 PGA20M	23" - 29" 585 mm - 740	14", 16", 18", 20" 350 mm, 405, 460, 510	4.8 LBS 2.2 kg
PGA20S	23" - 29" 585 mm - 740	14", 16", 18", 20" 350 mm, 405, 460, 510	4.8 LBS 2.2 kg
PG204 PG204M	21" 535 mm	12-1/2" 318 mm	3.1 LBS 1.4 kg

PG204

Fixed Long Reach



Rubber Pads for Adjustable Reach / Long Reach Pliers
2 sets per package

- For PG204 & PGA20
Part No : PP20
- For PGA20S
Part No : PP20S

Pipe Pliers

The convenient way to hold round or square tubes for butt-welding.

PG114V



Hold Round Parts Securely!



The V-Pads on the Pipe Pliers adapt to many different shapes & sizes.



NEW



XFVS

Stainless Steel V-Pads

PG622V
PG634V
PG114V

PG635V
8-1/2" Pliers
Two lrg V-Pads
Adj. Top V-Pad

PG635VS
8-1/2" Pliers
Two lrg SS V-Pads
Adj. Top V-Pad

Magnetic V-Pads and Stainless Steel V-Pads also sold separately. See Accessories page 33.

Features:

- Wide opening allows the Pipe Pliers to hold up to 2-1/2" (64 mm) diameter pipes.
- Adjustable top spindle for holding pipes of varying sizes.
- 2 large V-Pads provide a better clamping surface.
- 0° & 45° angle clip allows angled clamping.

Part No.	Feature	OAL	Throat Depth	Opening	Thread	Weight
PG622V	<ul style="list-style-type: none"> • 6" Pliers • Fixed V-Pads (2x XDV) 	6" 150 mm	2" 50 mm	1" - 2" 25 mm - 50	M8	0.8 LB 0.4 kg
PG634V	<ul style="list-style-type: none"> • 8-1/2" Pliers • Fixed V-Pads (2x XDV) 	8-1/2" 216 mm	3" 76 mm	2" - 3" 50 mm - 80	M8	1.1 LBS 0.5 kg
PG635V	<ul style="list-style-type: none"> • Adjustable Top V-Pad Spindle • Large V-Pads (XFV & XFV2) 	8-1/2" 216 mm	3" 76 mm	1-1/2" - 2-1/2" 38 mm - 64	M8	1.2 LBS 0.5 kg
PG635VS	<ul style="list-style-type: none"> • Adjustable Top V-Pad Spindle • S.S. V-Pads (XFVS) 	8-1/2" 216 mm	3" 76 mm	1-1/2" - 2-1/2" 38 mm - 64	M8	1.2 LBS 0.5 kg
PG114V PG114VM	<ul style="list-style-type: none"> • 11" Pliers • Fixed Large V-Pads (2x XFV) 	11" 280 mm	3-1/2" 89 mm	1-1/2" - 2-1/2" 38 mm - 64	3/8-16 M10	2.8 LBS 1.3 kg

Bench-Mount Pliers Holder

Convenient "Quick-Grab" Storage

- Holds in Vertical & Horizontal positions.
- Wing nuts on both vertical and horizontal position secures and locks pliers in place.

Part No.	Weight
PB11	0.2 LB 0.1 kg

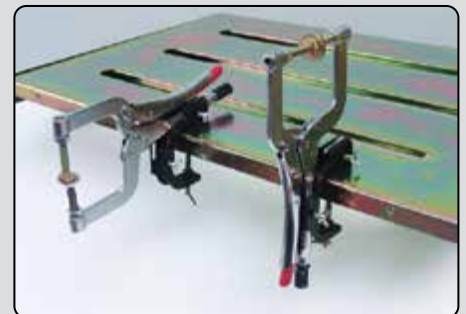
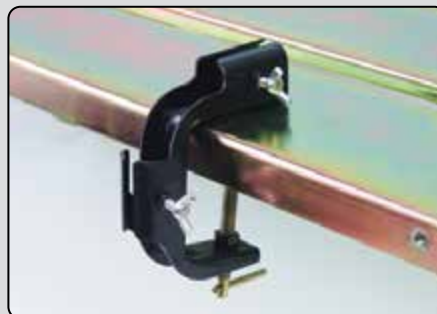

JointMaster™ Angle Clamping Tools

Fast, precise and affordable clamping tools for corners and T-joints.

PL Series

The single-hand corner clamping tool.

- Ideal for quick hold and release on metal, wood & synthetic materials.
- A "helping hand" to hold stock firmly at right angles while creating or repairing permanent joints.
- PL Series comes with 1 pair of pliers.

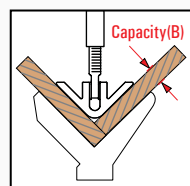

Capacity (B):
 PL622 : 0 - 3/4"
 PL634 : 0 - 1-1/4"

PT Series

The 90° Fixed JointMaster™

- Retractable plate for edge alignment
- V-Grooves for holding round pieces.
- Ideal for holding two pieces of different thicknesses that require individual adjustments.
- PT Series comes with 2 pairs of pliers.

PA Series

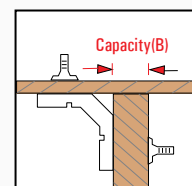
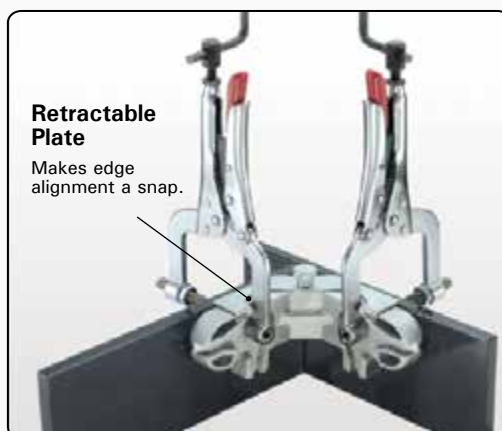

Capacity (B):
 PT622 : 0 - 1-1/4"
 PT634 : 0 - 3"

The Adjustable JointMaster™

- Adjustable from 30° - 275°.
- Adjust to the desired angle & "lock" into position with the handle.
- Join round & flat workpieces, or materials with different thicknesses.
- PA Series comes with 2 pairs of pliers.

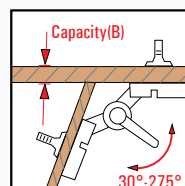

Capacity (B):
 PA622 : 0 - 1-1/4"
 PA634 : 0 - 3"

90° Clamp

- A quick way to hold workpieces at 90°.
- Capable of holding a 3-axis workpiece by adding a Pipe Pliers (see pg.12).
- Wide opening offers unobstructed welding access.



PL / PT / PA Series

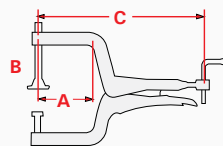

UDL365

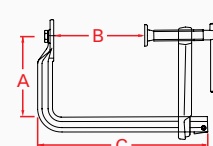

Part No.	Throat Depth (A)	Max. Capacity (B)	OAL (C)	Weight
PL622	2" 50 mm	3/4" 19 mm	7-1/2" 190 mm	1.0 LB 0.5 kg
PL634	3" 76 mm	1-1/4" 32 mm	8-1/2" 216 mm	1.1 LBS 0.5 kg
PT622	2" 50 mm	1-1/4" 32 mm	7-1/2" 190 mm	1.6 LBS 0.7 kg
PT634	3" 76 mm	3" 76 mm	8-1/2" 216 mm	2.5 LBS 1.1 kg
PA622	2" 50 mm	1-1/4" 32 mm	7-1/2" 190 mm	2.0 LBS 0.9 kg
PA634	3" 76 mm	3" 76 mm	8-1/2" 216 mm	2.4 LBS 1.1 kg
UDL365	3" 76 mm	2" 50 mm	9-1/2" 241 mm	1.7 LBS 0.8 kg

Locking Chain Pliers & Expand-O Pliers

The flexibility to clamp around odd shaped items!

Locking Chain Pliers

Holds 6" (152 mm) pipes with the standard 24" (60 mm) chain.

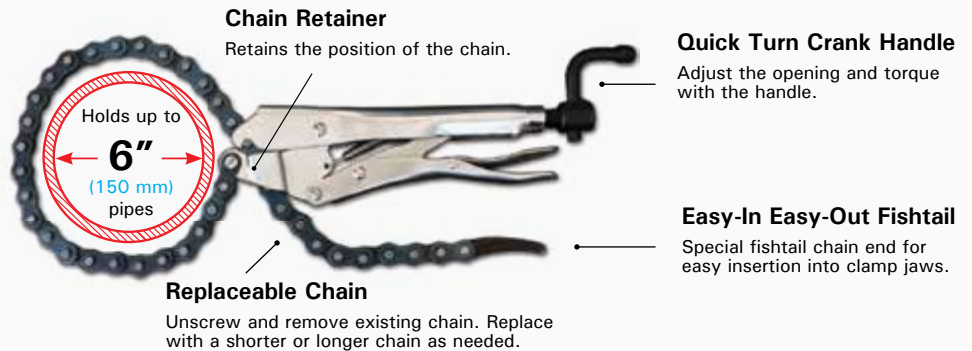

- Clamp around odd or awkwardly shaped items.
- Hold two workpieces, or a group of materials securely in place while you weld.
- The **ONLY** Locking Chain Pliers with replaceable chains of various lengths! Chain lengths from 16" (400 mm) to 48" (1,220 mm). **Custom length chains available.**
- Made of heat treated alloy steel for strength and durability.

Part No.	Description	OAL	Weight
PC924	Standard Chain Pliers with 24" (60 cm) chain	9" 230 mm	1.9 LBS 0.9 kg
PXC16	16" Replaceable Chain	16" 400 mm	0.5 LB 0.2 kg
PXC36	36" Replaceable Chain	36" 910 mm	1.0 LB 0.5 kg
PXC48	48" Replaceable Chain	48" 1,220 mm	1.4 LBS 0.7 kg

Expand-O Pliers Patent No. US 6,993,999 B2

Unique, Reverse-Action Clamping Pliers!

Jaws move in opposite directions to push against two surfaces.

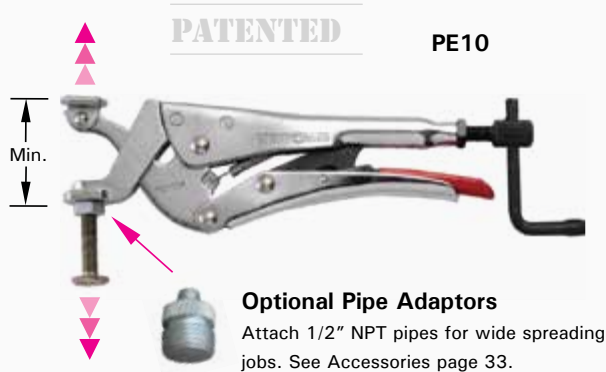

Expand-O Pliers with V-Pads and Extension Rod! (PEV6 & PEV10)

Features:

- One Magnetic V-Pad, One Standard V-Pad.
- Extension Rod increases reach by 2".
- Bottom Adjustable Magnetic V-Pad holds Pliers in place.
- The two V-Pads instantly adjust to round or flat surfaces.

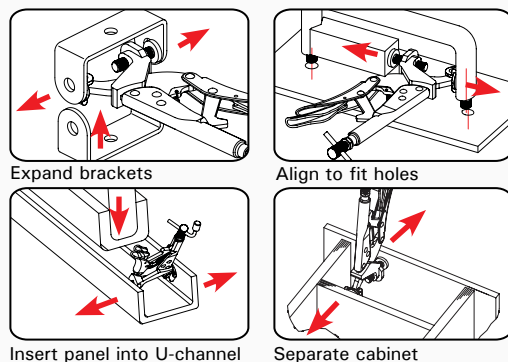
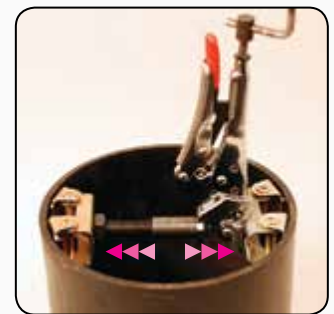
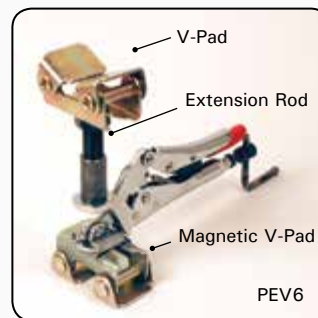

Part No.	OAL	Clamping Pressure	Thread	Min.	Stroke	Weight
PE6 PE6M	6-1/2" 165 mm	500 LBS 227 kg	5/16-18 M8	1" 25 mm	3/4" 19 mm	0.5 LB 0.2 kg
PE10 PE10M	10" 254 mm	900 LBS 410 kg	3/8-16 M10	1-3/8" 35 mm	1-3/8" 35 mm	1.8 LBS 0.8 kg
PEV6 PEV6M	6-1/2" 165 mm	500 LBS 227 kg	5/16-18 M8	1" 25 mm	3/4" 19 mm	0.8 LB 0.4 kg
PEV10 PEV10M	10" 254 mm	900 LBS 410 kg	3/8-16 M10	1-3/8" 35 mm	1-3/8" 35 mm	2.4 LBS 1.1 kg

Table Mount & Drill Press Clamps

Quick-set hold down clamps.

Table Mount Locking C-Clamps

- Mounts directly to any work bench, drill press, etc.
- Mounting base hole accepts standard 5/16"-18 bolts and uses push-down action to hold your workpiece securely.
- Use the Crank-Handle for rapid tightening.
- Rapid lock and release. Ideal for repetitious clamping.

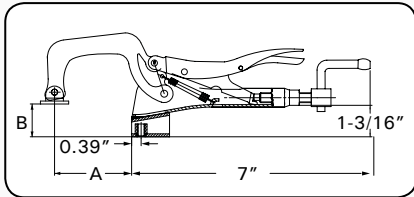

Part No.	Throat Depth (A)	Max. Capacity (B)	Mount Thread	Weight
PTT934 PT11	3-3/8" 86 mm	4" 100 mm	5/16-18 M8	1.6 LBS 0.7 kg
PTT956 PT14	6-1/8" 155 mm	4-3/4" 120 mm	5/16-18 M8	2.0 LBS 0.9 kg

NEW

Drill Press Clamp

Secure the Drill Press Clamp to any surface, up to 1" thick.

- 1/2-13 x 1.5 L Stud and convenient, ergonomic zinc plated knob.
- Total Weight: 1.9 LBS (0.86 kg).

PTTD634

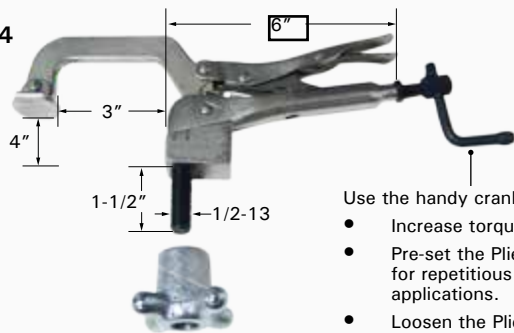

Use the handy crank handle to:

- Increase torque.
- Pre-set the Plier opening for repetitious clamping applications.
- Loosen the Plier before unlocking.



PTTD634

Drill Press Clamps quickly lock and release, making them ideal for repetitious clamping.

Shark Clamps

Patent No. US 6,983,012 B2

Pivoting, hinged arms provide a wide opening. Inside serrations hold workpieces securely.



SC65A

Shown with optional rubber pads. (P/N: SCP)

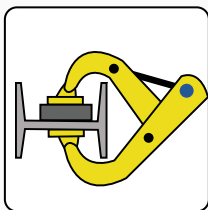

Step-Over Applications

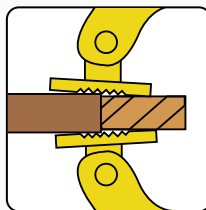

Uneven Thicknesses

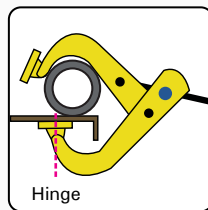

Clamp Round Parts

C-Clamping Jaw

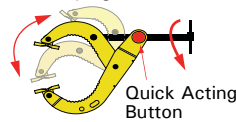

Fast Set-ups, just hold the button down and pull-push the handle to desired clamping position, release the button and turn the handle to tighten.



SC50A

Straight Handle Model with soft grip



SC50

T-Handle Model (Heavy Duty)

Part No.	Descriptions	Max. Pull Force	Opening	Weight
SC50	T-Handle	1,000 LBS 455 kg	5" 127 mm	2.2 LBS 1.0 kg
SC50A	Straight Handle	300 LBS 135 kg	5" 127 mm	2.0 LBS 0.9 kg
SC65	T-Handle	1,000 LBS 455 kg	6-1/2" 165 mm	2.5 LBS 1.1 kg
SC65A	Straight Handle	300 LBS 135 kg	6-1/2" 165 mm	2.2 LBS 1.0 kg

Handi-Hammer & Mag-Levels

Innovative magnets and levels with unique and updated features.

Handi-Hammer - The handle-less Tapper!

The Unique Dead-Blow Tapper

- One Steel End for hard surfaces.
- One Soft Face for non-marring applications.
- Eliminates bounce back and increases impact.
- Fits easily in Tool Kits, Tool Boxes & Work Bench Drawers.
- Ideal for confined areas!



Part No.	Dimension	Weight
CH-10	1-5/8"Ø x 5" 40 mm Ø x 127	0.6 LB 0.3 kg
CH-14	1-3/4"Ø x 5-1/4" 45 mm Ø x 133	0.9 LB 0.4 kg

Mag-Level Patent No. US 7,009,480 B2

- The only magnetic level with the On/Off switch.
- Holds securely to round and flat surfaces.
- Three vials for 0°, 45°, 90° reading.

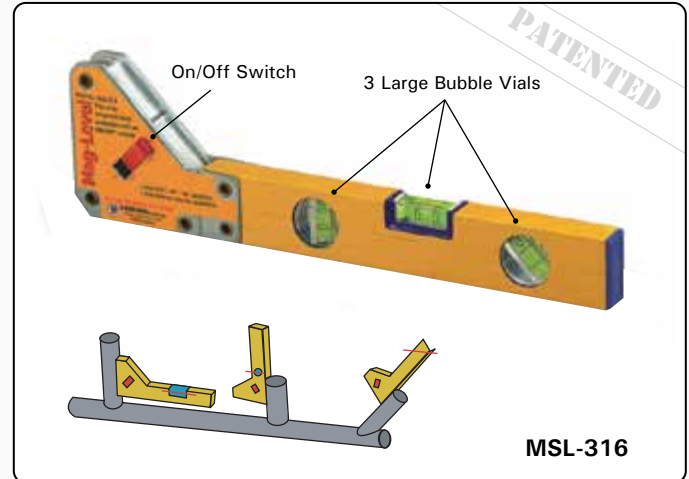

Part No.	Angles	Dimension	Max. Pull Force	Weight
MSL-316	45°, 90° 180°	4" x 16" x 1" 100 mm x 406 x 25	70 LBS 30 kg	2.0 LBS 0.9 kg

*Magnetic force is based on the 3/8" thick steel.

Torpedo Mag-Levels



The use-anywhere, view anywhere compact magnetic level.

- 4 strong magnets allow hands-free use on metal surfaces.
- V-Groove on one side for pipe and conduit work.
- Robust, solid anodized aluminum body.

1/4" Chamfer
Allows the level to be easily aligned with the side of the workpiece.

Z-Axis Bubble Pod
The add-on pod provides accurate leveling of 2-axes. The pod can be rotated for easy viewing from different angles and heights.

Elastic Velcro® Strap (LM3723 only)
Allows the level to be easily attached to non-magnetic surfaces. The strap fits snugly into the hole for safe keeping.

Part No.	Dimension	Angles	Weight
LM3723	7" x 1-1/4" x 1" 180 mm x 32 x 25	0°, 45°, 90°	0.4 LB 0.2 kg
LM2422	4" x 1-1/4" x 1" 100 mm x 32 x 25	0°, 90°	0.3 LB 0.1 kg

PowerBase & Ground Hog Grounding Tools

Power through your grounding applications!

PowerBase™ Grounding Magnet



Turn OFF the PowerBase™ Grounding Magnet and metal chips fall away.

Power through your grounding applications! Start grounding instantly!

- The PowerBase™ Grounding Magnet sets up quickly and easily.
- Powerful rare earth magnet delivers heavy duty holding power.
- The “V” machined surface grips round parts.
- The copper connector stud allows for better conductivity.



Large copper connector for better conductivity.



Holds securely onto round or flat surfaces.



The ON/OFF Lever is easy to turn, even while wearing gloves.

Part No.	Amperage	Dimension	Magnetic Force	Weight
GM203	300A @ 60% Duty Cycle	2" x 2" x 1.4" 50 mm x 50 x 64	44 LBS 20 kg	0.9 LB 0.4 kg
GM205	500A @ 60% Duty Cycle	2" x 2.75" x 1.4" 50 mm x 70 x 64	110 LBS 50 kg	2.4 LBS 1.1 kg

Ground Hog™ Clamps



Ground Hog™

Rated at 530 AMPS @ 60% duty cycle (with 3/0 cable)

GP950

High clamping pressure improves arc stability and reduces power consumption.

- Prevents current restriction and allows complete current transfer.
- Controls the electrical current by isolating the contact surface and the cable connection.
- Get a smooth, continuous arc with no fade, and no heat transfer while improving cable life, and reducing power consumption.

The Ground Hog

- The groove design on the copperhead seals out weld spatter and reduces particle buildup.
- Side screw provides a secure cable connection.
- Ground Hog body rotates for cable positioning.

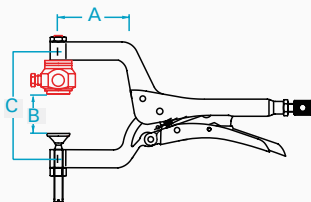

Strong Grip™ Ground Clamp

DUAL FUNCTION Clamping & Grounding



GB428

Consistently rated at 300 AMPS
Solid, insulated copper U-channel rotates for easy access and can attach to round / odd-shaped parts.



SQUEEZE to open

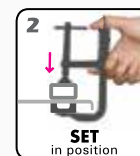

SET in position

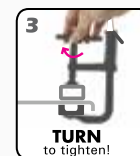

TURN to tighten!

Part No.	Amperage / Cable Size	Throat Depth (A)	Max. Capacity (B)	Tapped Hole (C)	Clamping Pressure	OAL	Weight
GP950 GP2850	450A / 2/O - 0.427"	3-1/2" 89 mm	2-1/2" 64 mm	3/8-16 M10	400 LBS 180 kg	11" 280 mm	2.4 LBS 1.1 kg
GP951 GP2851	530A / 3/O - 0.475"	3-1/2" 89 mm	2-1/2" 64 mm	3/8-16 M10	400 LBS 180 kg	11" 280 mm	2.4 LBS 1.1 kg
GB428	300A / --	2-1/2" 64 mm	3" 75 mm	1/4-20 M6	220 LBS 100 kg	7" 180 mm	0.8 LB 0.4 kg

Welders Angle Clamps

2 and 3 Axis Fixture Visas

3-Axis Welders Angle Clamps

Patent No. US 6,860,475 B2

Holds a 3-axis workpiece in position before welding.

- Features the **Quick Acting Screws** and **"Swing Away" Arm**.

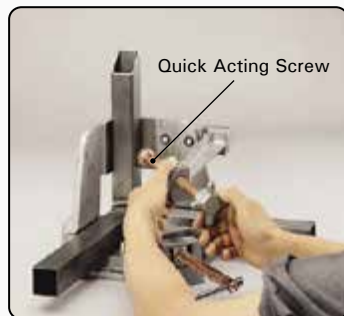

WAC45-SW
4-3/4" (120 mm)
Capacity!



- With the push of the buttons, the threaded screws easily slide in and out.
- When the job is finished, simply "swing away" the 3rd Axis arm for quick and easy part removal.
- Hold parts in position during cool down to minimize distortion due to contraction.
- Available in 3.75" and 4.75" capacities. Model WAC45-SW comes with a curved arm for greater workpiece clearance.

2-Axis Welders Angle Clamps

Made with machined cast iron. Featuring these improvements:

- Machined outside faces - usable for upright joint
- Stand-off increases access
- Quick acting screw on deluxe models.

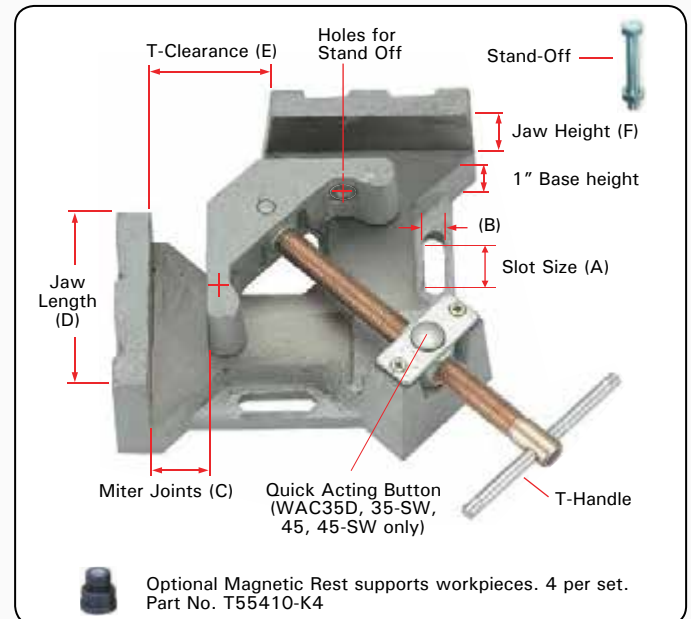

Upright Position



T-Joints



Stand-Offs



Tubes

	Part No.	Features	(A)	(B)	(C)	(D)	(E)	(F)	Weight
2-Axis	WAC22	Standard screw, Machined on two outside surfaces	0.94" 23.9 mm	0.31" 8.1 mm	2.21" 56 mm	3.54" 90 mm	1.85" 47 mm	1.28" 33 mm	8.8 LBS 4.0 kg
	WAC34	Standard screw	1.18" 30 mm	0.43" 11 mm	3.75" 95 mm	4.80" 122 mm	2.45" 62 mm	1.38" 35 mm	11 LBS 5.0 kg
	WAC35D	Quick Acting Screw, Two stand-offs, Machined on two outside faces	1.18" 30 mm	0.43" 11 mm	3.75" 95 mm	4.80" 122 mm	2.45" 62 mm	1.38" 35 mm	11 LBS 5.0 kg
	WAC45	Quick Acting Screw, Two stand-offs, Machined on two outside faces	2" 50.9 mm	0.43" 11.1 mm	4.75" 120 mm	5.32" 135 mm	3.92" 100 mm	2.25" 57 mm	23 LBS 11.0 kg
3-Axis	WAC35-SW	3-Axis Fixture, Quick Acting Screw, Two stand-offs "Swing Away" Arm	1.18" 30 mm	0.43" 11 mm	3.75" 95 mm	4.80" 122 mm	2.45" 62 mm	1.38" 35 mm	24 LBS 11.0 kg
	WAC45-SW	3-Axis Fixture, Quick Acting Screw, Two stand-offs "Swing Away" Arm, Two magnetic rests	2" 50.9 mm	0.43" 11.1 mm	4.75" 120 mm	5.32" 135 mm	3.92" 100 mm	2.25" 57 mm	43 LBS 20.0 kg

* Optional **Magnetic Rest** supports workpieces. 4 per set. Part No. T55410-K4. 0.5 LB (0.23 kg)

PATENTED

Portable MagVise™ & 90° Tru AngL

Time saving aluminum vises for use in the shop and in the field.

Portable MagVise™

Use the lightweight, compact Portable MagVise for quick 90° clamping in the shop, or in the field!

Magnets in the walls instantly hold pipes, tubes, angle iron, or metal plates in position for fast, accurate clamping at 90°.



Model WK50

Features the Quick-Acting Adjustable Spindle. Press and hold the Quick Acting Button and the spindle assembly slides in and out for a super fast set-up! Release the button and the threads re-engage for tightening.



The rotateable spindle allows for holding workpieces with different thicknesses.

The pliers can mount from front side of the MagVise.

Model WP60

Features a Plier/Vise combination for clamping flat workpieces, such as metal plates and angle iron. Pliers can be detached from the vise for easy removal of welded stock.



Use the provided leveling screw and optional Magnetic Rests to level long workpieces.

When the job is finished, easily slide the pliers out of the WP60 MagVise.

Optional Magnetic Rests

Part No. T55410-K4

4 pcs. per set

These handy Magnetic Rests are ideal for light duty holding, positioning, or steadying long metal pieces and parts.



Part No.	Features	Miter Joints	Jaw Length	T-Clearance	Jaw Height	Weight
WK50	MagVise™ with Adjustable Spindle	1" / 25 mm	3.35" / 85 mm	1.2" / 30 mm	2" / 50 mm	1.7 LBS / 0.8 kg
WP60	MagVise™ with Pliers	1" / 25 mm	3.35" / 85 mm	1.2" / 30 mm	2" / 50 mm	1.9 LBS / 0.9 kg
WP601	MagVise™ Only	1" / 25 mm	3.35" / 85 mm	1.2" / 30 mm	--	0.9 LBS / 0.4 kg

Aluminum 90° Tru-AngL

- Accurate Right Angle Fixture is CNC machined for accuracy.
- Weld spatter proof & made of high strength aluminum alloy.
- Holds round, square, flat and angle shapes.
- Works on both the outside and inside surfaces.

Part No.	Jaw Length (A)	T- Clearance (B)	Jaw Height	Weight
LF-2	7" / 180 mm	1-1/2" / 38 mm	2-1/2" / 64 mm	3.0 LBS / 1.4 kg

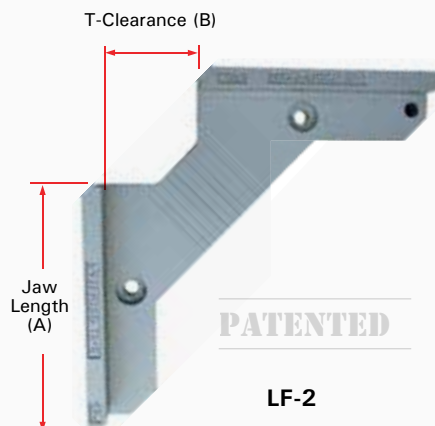

Pliers sold separately. Please refer to page 18.

NOMAD™ Economy Welding Table

Very Affordable. Fully Adjustable. Easily Movable.

The Nomad Economy Welding Table is engineered to provide a safe, transportable, affordable, and versatile welding surface.

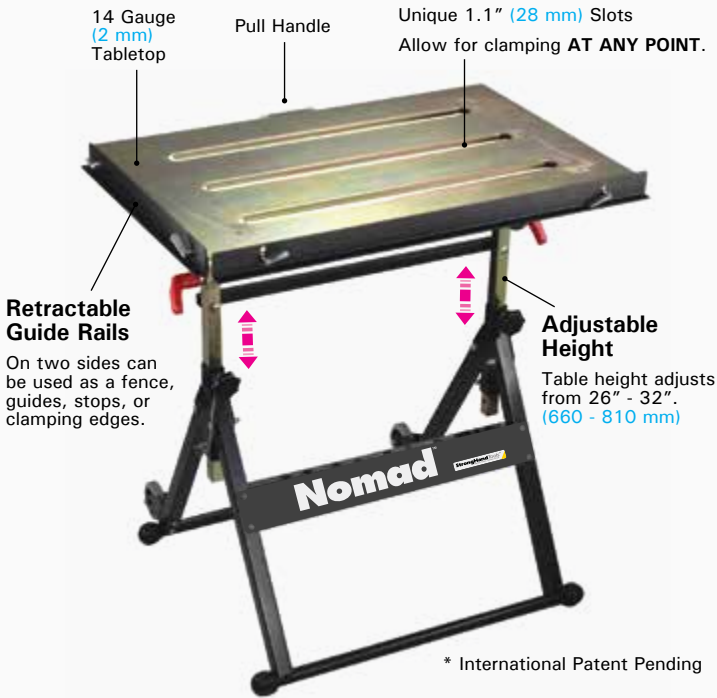

- Three 1.1" (28mm) slots in the tabletop allow for insertion of clamps to reach any point on the table.
- Tabletop tilts to three positions: Horizontal, 30°, and folded for mobility.
- Two retractable, perpendicular steel guide rails can be used as guides, stops, or clamping edges.
- Tabletop height can be adjusted from 26" to 32".
- Table moves about the work area on 2 sturdy casters.

Tabletop adjusts to three positions:

Horizontal, 30°, and Folded for Compact Storage and Mobility.



Part No.	Tabletop Size	Table Height Range	Slot in Tabletop	Table Positions	Load Capacity	Weight
TS3020	30" W x 20" L 760 mm x 510	26" - 32" 660 mm - 810	1.1" 28 mm	0°, 30°, Folded	350 LBS 160 kg	44 LBS 20 kg

Nomad™ Economy Tool Kit

This 6 piece tool kit contains useful tools to use in conjunction with the table.

Part No. **TSK104 (TSK104M)**

- 2 MagSpring Clamps (UBV45)
- 1 Multi-Angle Magnet (MS346C)
- 1 Mini-Magnet (MS346A)
- 2 Adjustable Magnet V-Pads (XDV4)

2 MagSpring™ Clamps
(UBV45 - 3" Cap.)



1 Multi-Angle Magnet
(MS346C)



1 Mini Magnet
(MS346A)



2 Adjustable Magnetic V-Pads
(XDV4 - 4 magnets)



Nomad™ Connector Plate

Need more tabletop workspace? Use the Nomad™ Connector Plate to join two Nomad Tables together to create a **7.5' (2.3 m)** long workstation!

Clamp and work on larger projects, or multiple projects with the fully adjustable work surface! There are thru holes on all four sides of the Connector Plate for multiple mounting options.

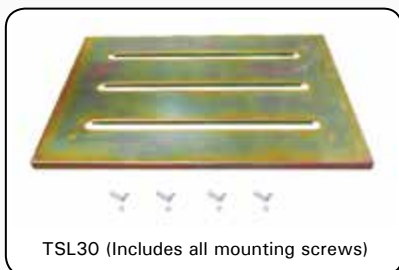

Part No.	Weight
TSL30	16.4 LBS 7.4 kg

Assembly Example

(All Products sold separately)

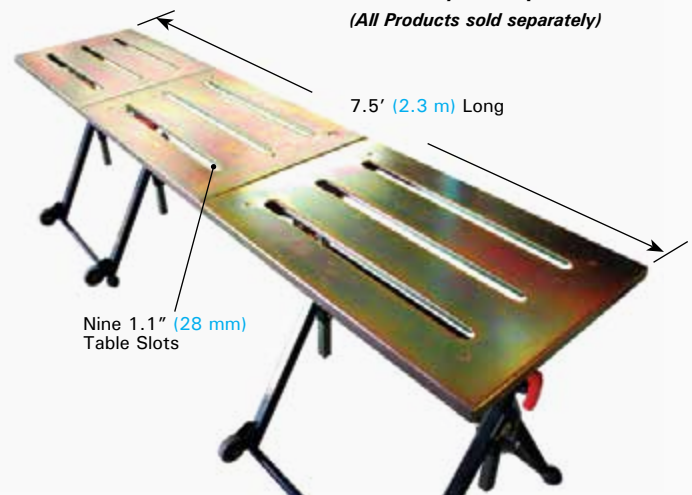

Platen Clamps & MIG/TIG Gun Holders

Platen and Universal Tabletop Clamps.

Modular Platen Clamps

For fast, secure clamping, simply insert the clamp into the 1-3/4" square hole in your acorn platen. Slide the clamp arm down to the work piece and turn the T-Handle to tighten.

- Choose from Acorn Bushing or Table Mount Models.
- Clamp comes with standard or heavy duty Swivel Pads.
- Unique optional Side-Kick Attachment provides push-action horizontal clamping force. (See accessories page 33)
- Optional V-Pads can be mounted on the Sliding Arm or Side-Kick Attachment. (See accessories page 33)

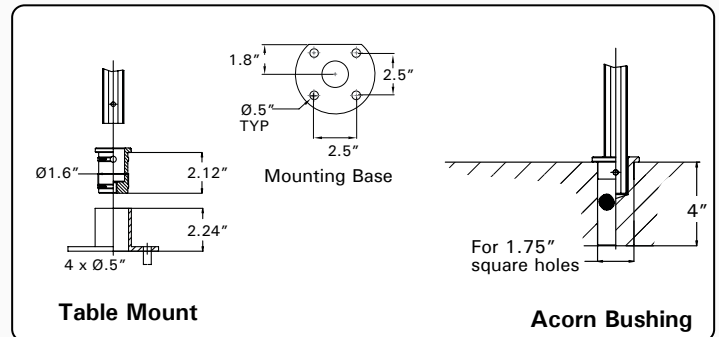
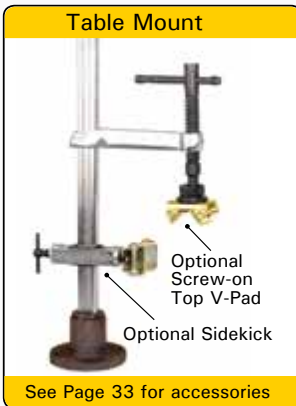

Table Mount

Part No.	Rail Size	Pad	Opening	Throat	Weight
UF8NC	"F"	Standard	8" 203 mm	4-3/4" 120 mm	4.9 LBS 2.2 kg
UF10NC	"F"	Standard	10" 254 mm	4-3/4" 120 mm	4.9 LBS 2.2 kg
UF12NC	"F"	Standard	12" 305 mm	4-3/4" 120 mm	5.4 LBS 2.4 kg
UM12NC	"M"	Heavy Duty	12" 305 mm	5-1/2" 140 mm	8.0 LBS 3.6 kg
UM16NC	"M"	Heavy Duty	16" 406 mm	5-1/2" 140 mm	8.7 LBS 4.0 kg
UM20NC	"M"	Heavy Duty	20" 508 mm	5-1/2" 140 mm	9.4 LBS 4.3 kg

Acorn Bushing

Part No.	Rail Size	Pad	Opening	Throat	Weight
UF8NA	"F"	Standard	8" 203 mm	4-3/4" 120 mm	5.0 LBS 2.3 kg
UF10NA	"F"	Standard	10" 254 mm	4-3/4" 120 mm	5.2 LBS 2.4 kg
UF12NA	"F"	Standard	12" 305 mm	4-3/4" 120 mm	5.4 LBS 2.4 kg
UM12NA	"M"	Heavy Duty	12" 305 mm	5-1/2" 140 mm	8.0 LBS 3.6 kg
UM16NA	"M"	Heavy Duty	16" 406 mm	5-1/2" 140 mm	8.8 LBS 4.0 kg
UM20NA	"M"	Heavy Duty	20" 508 mm	5-1/2" 140 mm	9.6 LBS 4.4 kg

NEW MIG / TIG Gun Holders

Handy Accessory Plate (included with Part Nos. MRM12, MRM13) features a slot for MIG Pliers and a Nozzle Gel Canister. Fully enclosed Magnetic Base allows easier clean up of metal fuzz. Part No. MRM13 Kit contains the MIG Gun Holder (MRM12), and MIG Pliers (PM08).

Part No.	Description	Dimension	Weight
MRM12	MIG Gun Holder with Accessory Plate	3.5" Ø x 6" x 5.3" 89 mm Ø x 152 x 135	2.8 LBS 1.27 kg
PM08	MIG Pliers	8" 203 mm	0.6 LB 0.27 kg
MRM13	MIG Gun Holder with Accessory Plate & MIG Pliers	--	3.4 LBS 1.54 kg
MRT15	TIG Gun Holder	3.5" Ø x 6.3" 89 mm Ø x 160	1.8 LBS 0.82 kg

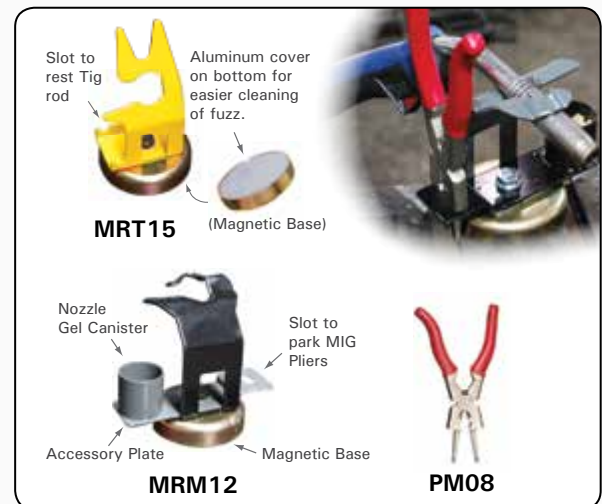

Hold Down, Half & Side Clamps

Hold down action clamps with unique features and accessories.

Hold Down Clamps

Bolt the clamp down to your worktable using the 3/8" hole in the base.

- The 1/2" copper plated Acme spindle resists weld spatter, and the swivel tip makes quick contact with your workpiece.
- Hold pipes by adding our Clip-On V-Pad, Part #XDA2. (See accessories page 33).

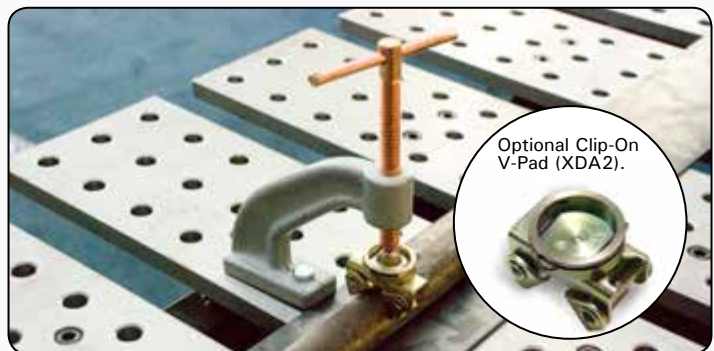
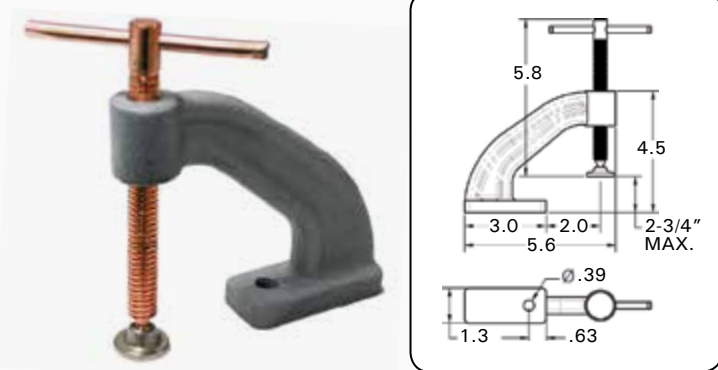

Part No.	Capacity	Weight
VHD30	2-3/4" 70 mm	2.0 LBS 0.9 kg

Copper Plated Acme Screw / Ductile Iron Body

Half Clamps Patent No. US 6,983,525 B2



The Efficient, Safe Way to Align Materials.

- The DOG & WEDGE and CUT-OFF C-CLAMP methods of material alignment are messy, time consuming, and unsafe!
- Align materials in the fabrication of water tanks, bulkheads, deck sections, flat plates, etc.
- For big jobs, tack weld additional 1-1/2" cut pipes along the joint.

How to Use

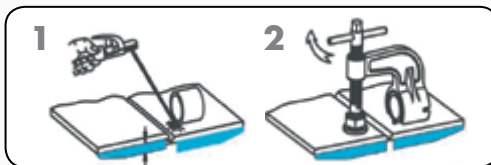

Tack weld the front side of 1-1/2" pipe coupon to the lower of the two surfaces. Slide Half Clamp onto the cut pipe, turn the handle until the misaligned materials align.

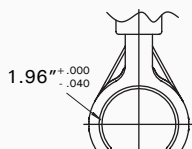
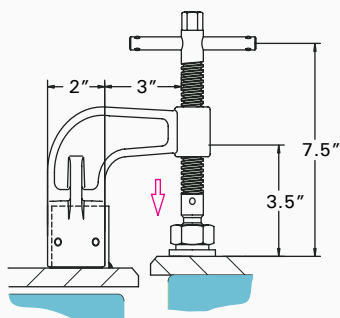

Copper Plated Acme Screw / Ductile Iron Body

Part No.	Weight
VHC15	3.7 LBS 1.7 kg

Side Clamps

Build push-action clamp to custom heights. Insert pipe (1-1/2" dia.) of desired length. Base can be bolt-mounted to the table.

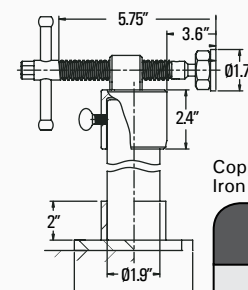

Copper Plated Acme Screw / Ductile Iron Body

Part No.	Weight
VSC15	5.6 LBS 2.6 kg

Strong Hand Tools® Clamping Kits

Receive 10% off list price on the clamping kits and receive a **FREE** gift!

Having the right tools on hand makes every job easier to complete. These kits contain the most essential tools for clamping, holding, and positioning steel. Efficiency + Cost Savings are an unbeatable combination.

Utility Clamp Kit #1

Part No. UDK4-5 (UDMK4-5)

1  **UD45 (UD45M)**
 - Capacity: 4-1/2" (114 mm)
 - Clamping Pressure: 500 LBS (227 kg)
 - Throat Depth: 3-1/4" (83 mm)

1  **UD65 (UD65M)**
 - Capacity: 6-1/2" (165 mm)
 - Clamping Pressure: 500 LBS (227 kg)
 - Throat Depth: 3-1/4" (83 mm)

1  **UD85 (UD85M)**
 - Capacity: 8-1/2" (216 mm)
 - Clamping Pressure: 500 LBS (227 kg)
 - Throat Depth: 3-1/4" (83 mm)

2  **GIFT**
FREE V-Pads (XDV)
 - UD Clamping accessory
 - Holds round and angled workpieces.

Utility Clamp Kit #2

Part No. UFK4-4 (UFMK4-4)

1  **UF65 (UF65M)**
 - Capacity: 6-1/2" (165 mm)
 - Clamping Pressure: 1,000 LBS (454 kg)
 - Throat Depth: 4-3/4" (120 mm)

1  **UF100 (UF100M)**
 - Capacity: 10" (254 mm)
 - Clamping Pressure: 1,000 LBS (454 kg)
 - Throat Depth: 4-3/4" (120 mm)

1  **UF110R (UF100RM)**
 - Ratchet Action Utility Clamp
 - Capacity: 8-1/2" (216 mm)
 - Clamping Pressure: 1,000 LBS (454 kg)
 - Throat Depth: 4-3/4" (120 mm)

1  **GIFT**
FREE Sidekick (XFS)
 - Fits all UF Rails
 - Allows for 2-axis horizontal clamping.

Adjust-O Magnet Kit

Part No. MK4-4

1  **MSA45**
 - Adjust-O™ Magnet Square
 - Hold at 45° & 90°
 - Max. Pull Force : 65 LBS (30 kg)

1  **MSA53-HD**
 - Adjust-O™ Magnet Square
 - Hold at 30°, 45°, 60°, 90°
 - Max. Pull Force : 140 LBS (64 kg)

1  **MSL-316**
 - Mag-Level with On/Off Switch
 - Three vials for 0°, 45° & 90° reading
 - Max. Pull Force : 70 LBS (32 kg)

1  **GIFT**
FREE Magnetic Post Set
 - 3rd-Axis Magnetic Posts (MXE13)
 - Easily set-up 3-axis workpieces.
 - Fits all Adjust-O™ Magnet Squares

Magnetic Clamping Kit

Part No. TSK104 (TSK104M)

2  **UBV45 (UBV45M)**
 - MagSpring™ Clamp
 - Capacity : 3" (75 mm)
 - Throat Depth : 2-1/2" (64 mm)

1  **MS346C**
 - Standard Magnet Squares
 - Hold at 30°, 45°, 60°, 90°
 - Max. Pull Force : 85 LBS (39 kg)

2  **XDV4**
 - Magnetic V-Pads
 - Light duty & tight spot holding
 - Build, hold, and position steel

1  **GIFT**
FREE Mini-Magnet
 - Original Mini Magnet (MS346A)
 - Hold at 30°, 45°, 60°, 90°
 - Max. Pull Force : 25 LBS (10 kg)

All items can be purchased separately.

Accessories

Replacement Parts and Accessories.

U-Clamps Replaceable Parts

Replaceable Arm and Spindle Kits

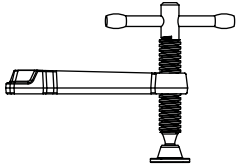

P/N For U-Clamps Series

XER	UE Series
XFR	UF Series
XGR	UG Series
XMR2	UM Series (Equipped with H.D. Pad)
XMRP2	UM Series (Equipped with Standard Pad)
XPR	UP Series

Individual Clamp Arms and Spindles

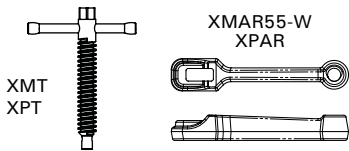

P/N Description

XMT	Spindle for UM Series
XPT	Spindle for UP Series
XMAR55-W	Clamp Arm for UM Series
XPAR	Clamp Arm for UP Series

Spring Stop Replacement Kit

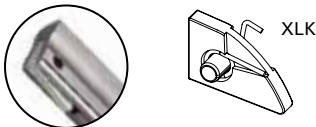

P/N Description

XLK	For UE, UF, UG & UM series clamps.
-----	------------------------------------

Pliers Replacement Parts

Spring & Adjustment Bolt for Pliers

Spring - 4 per set
PXS11
PXS6



Adjustment Bolt

PXB11
PXB6



P/N For Pliers

PXS11	11" Pliers
PXS6	6" & 8-1/2" Pliers
PXB11	11" Pliers
PXB6	6" & 8-1/2" Pliers

Swivel / Pivot Pads (For Pliers)

Flat pads pivot at 150° and round pad swivels at 360°.

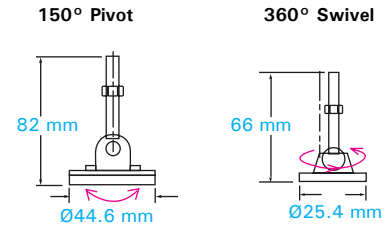

P/N	Thread	Height	Pad OD
854944M (Pivot)	M10	82 mm	44.6 mm
854940M (Swivel)	M10	66 mm	25.4 mm

Crank Handles (For Pliers)

Optional or replacement handles for all Strong Hand Tools™ Pliers.

PXH6

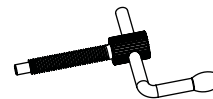

PXH11

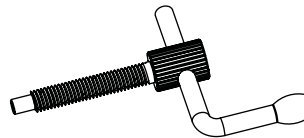

P/N Thread For Pliers

PXH11	M10	11" Pliers 280 mm
PXH6	M6	6", 8-1/2" Pliers 216 mm

Big Hex Spindles (For Pliers)

Fixed head spindles for Multi-Purpose Pliers.

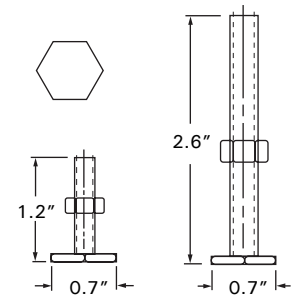

P/N Thread Length

854714	3/8-16	2.6"
854714M	M10	66 mm
854713	5/16-18	1.2"
854713M	M8	30 mm

Heavy Duty Replaceable Pads

Replacement joints and pads for UM & UP clamps.

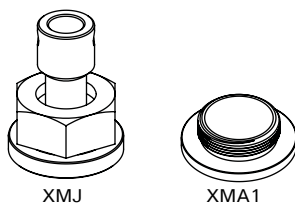

P/N Description

XMJ	Joint & Pad Kit for UM & UP Clamps
XMA1	Replacement Pad only

Fixed Glides (For Pliers)

With non-marring rubber pads.

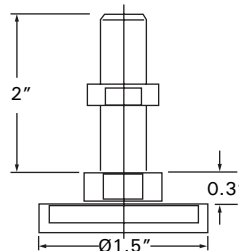

P/N Thread Length

854740P	3/8-16	2"
854740PM	M10	51 mm

T-Strap Bolts (For Pliers)

For Step-Over applications.

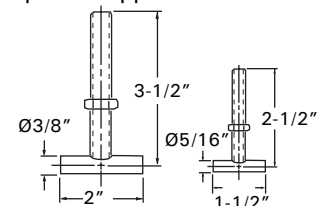

P/N Thread Length

840435	3/8-16	3-1/2"
840435M	M10	89 mm
840335	5/16-18	2-1/2"
840335M	M8	64 mm

Accessories

Accessories for Utility Clamps, Multi-Purpose Pliers and Expand-O Pliers.

V-Pads (For U-Clamps & Pliers)

Standard V-Pads

To hold round & angled workpieces.

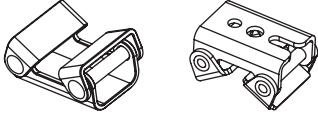

P/N	Tapped Hole	For Clamps	For Pliers
XDV	5/16-18 M8	UD Series	PG622 / PG634
XFV	3/8-16 M10	UE, UF, UG Series	PG114 / PG134 PG204 / PGA20
XMV	3/8-16 M10	UM, UP Series	--
XPV	3/8-16 M10	UP Series	--
XDVS	5/16-18 M8	UD Series	PG622 / PG634
XFVS	3/8-16 M10	UE, UF, UG Series	PG114 / PG134 PG204 / PGA20
XMVS	3/8-16 M10	UM, UP Series	--

Stainless Steel

Pliers Replacement Parts

Rare earth magnetic V-Pads for holding round and angled pipes.

2 magnets Version (Top only):
XDV2 / XFV2

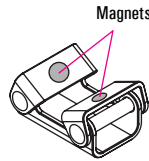

4 magnets version (Top & Bottom):
XDV4 / XFV4

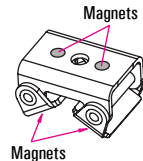

» XDV4 & XFV4 are table mount versions.

P/N	Tapped Hole	For Clamps	For Pliers
XDV2	5/16-18 M8	UD Series	PG622 / PG634
XDV4	5/16-18 M8	--	--
XFV2	3/8-16 M10	UE, UF, UG Series	PG114 / PG134 PG204 / PGA20
XFV4	3/8-16 M10	--	--

4-IN-1 Packages (For U-Clamps)

Convert all Utility Clamps into 4-IN-1 Clamps. Includes a V-pad, an Extender Block, and a screw.

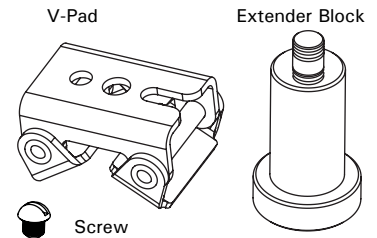

P/N	V-Pad / Extender Block
XDVB XDVBMB	XDV / XDB1 (For UD Models)
XFVB XFVBMB	XFV / XFB (For UE, UF, UG Models)
XMVB XMVBMB	XMV / XMB2 (For UM, UP Models)

Top V-Pads (For U-Clamps)

Attach to the top of Utility Clamps equipped with **Standard Pads**.

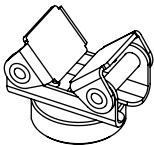

» Light Duty & Value Series

P/N	For U-Clamps Series
XDA2	UD Series
XFA2	UE, UF, UG Series
XMA2	UM, UP Series
XDA2S	UD Series
XFA2S	UE, UF, UG Series
XMA2S	UM, UP Series

Stainless Steel

Extender Blocks (For U-Clamps)

Attach to U-Clamps for Step-Over and Spreading applications.

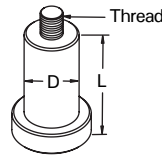

P/N	Thread	D	L	For Clamps
XDB1 XDB1M	5/16-18 M8	5/8" 16 mm	1" 25 mm	UD Series
XFB XFBM	3/8-16 M10	45/64" 18 mm	2" 51 mm	UE, UF, UG Series
XMB2 XMB2M	3/8-16 M10	7/8" 22 mm	2" 51 mm	UM, UP Series

Sidekicks (For U-Clamps)

Mount onto U-Clamps for 2-axis horizontal clamping.

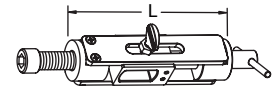

P/N	L	Stroke	For Clamps
XDS XDSTM	3-1/8" 79 mm	1" 25 mm	UD Series
XFS XFSTM	4-3/8" 111 mm	1-3/8" 35 mm	UF Series
XGS XGSTM	4-3/8" 111 mm	1-3/8" 35 mm	UG Series
XMS XMSM	4-3/8" 111 mm	1-3/8" 35 mm	UM Series

Screw-On V-Pads

Attach to the top of Utility Clamps equipped with **Heavy Duty Pads**.

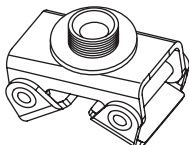

» For Regular and Heavy Duty Series

P/N	For U-Clamps Series
XMA	UM, UP Series
XMAS	UM, UP Series

S.S.

Bench Rests (For U-Clamps)

Supports U-Clamp in Standing Position.

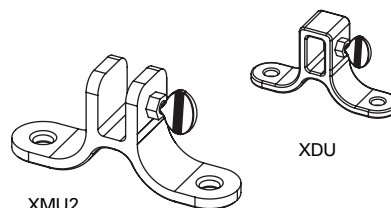

P/N	For U-Clamps Series
XDU	UD Series
XMU2	UM Series

Pipe Adaptors (For Expand-O Pliers)

Attach to Expand-O Pliers for wide spreading jobs and U-clamps for Step-Over applications.

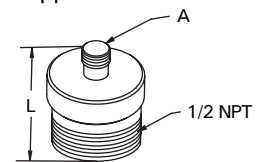

P/N	L	A	Expand-O	For Clamps
XDJ XDJM	1-1/16" 27 mm	5/16-18 M8	PE6, PE62 PE6M, PE62M	UD Series
XFJ XFJM	1-5/32" 29 mm	3/8-16 M10	PE10 PE10M	UE, UF, UG, UM, UP

Ideal time-saving jig and fixture clamps.

Standard Machine Parts & Tooling Components.

**Vertical Handle
Hold Down Action**



**Horizontal Handle
Hold Down Action**



**Push/Pull
Straight Line Action**

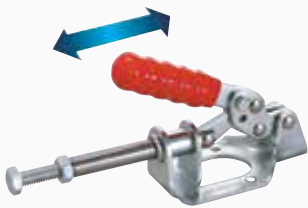

**Latch Type
Pull Action**



**Cam Type
Hold Down Action**

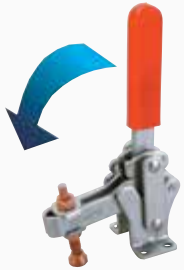

**Toggle Pliers
Squeeze Action**



**F-Type
Pull Down Action**



Pneumatic Power



Yoke Assemblies



**Heavy Duty Weldable
Hold Down Action**



Contact us for complete catalog.

Bedding Supports



Cam Action Clamps



Forged Adjusta-Clamps



Adjustable Handles



Center Cam Clamps



Rotary T-Slot Nuts



Handwheels



Spring Stops



Handknobs



Cap Screw Hook Clamps



Speed Ball Handles



Lifting Eyebolts



Leveling Pads



Crank Handles



Heavy Duty Fixed Glides



Clamping Levers



T-Slot Bolts



Rotary T-Slot Bolts



Plain Eyebolts



T-Strap Bolts



Contact us for complete catalog.

Faster Fixturing. Consistent Results. Greater Productivity.

The affordable, professional BuildPro™ Welding Tables are setting a new standard in price and performance.

The BuildPro's modular design gives you the flexibility to adapt to each new project easily. You'll work more safely, and more efficiently, so you can increase both your productivity, and the quality of your work.

Precision, ground steel plates, with CNC machined 5/8 holes in a 2" grid pattern for locating, positioning and holding your fixture with the BuildPro™ clamps and components.

1-3/4" T-slot spacing designed for optimum flexibility.

Plates can be reconfigured to extend the width of the table for larger projects.

Heavy Duty Leveling Feet ensure proper leveling of the table on uneven surfaces.

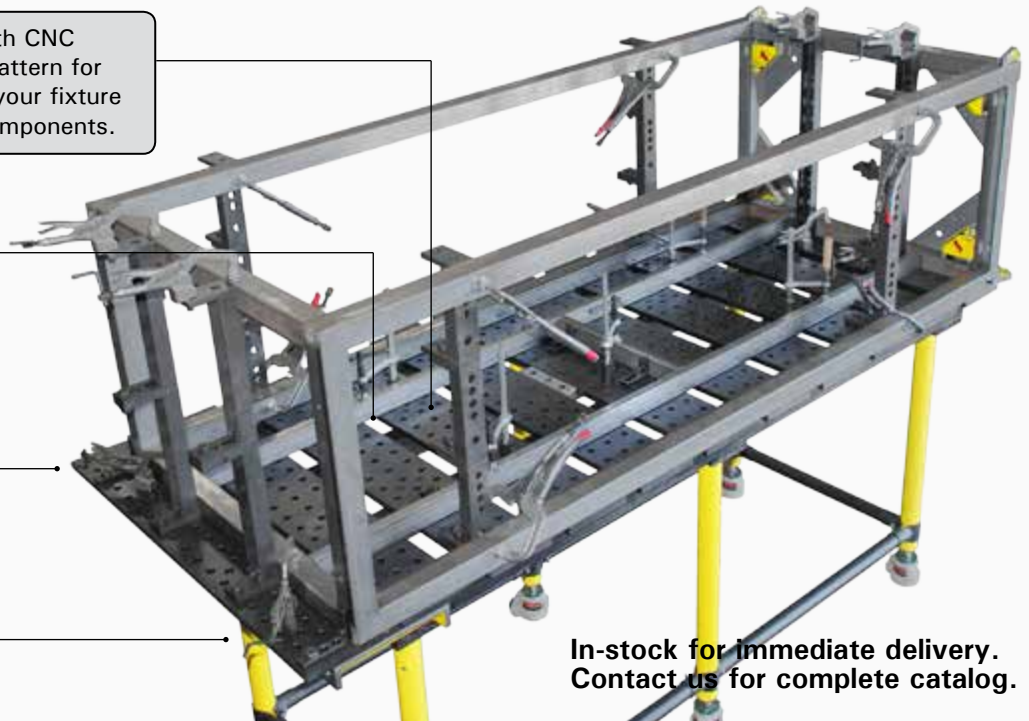

In-stock for immediate delivery. Contact us for complete catalog.



Made in Germany 

SIEGMUND High Precision Welding Tables and Clamping Systems.

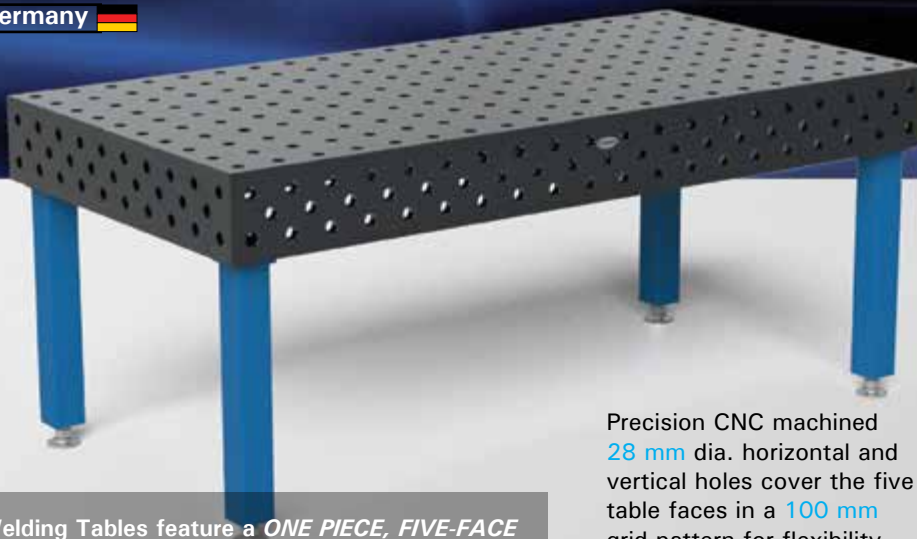

Siegmond Welding Tables feature a **ONE PIECE, FIVE-FACE** design with **25 mm** thick reinforced steel plate for an extremely rigid and flat work surface with a load capacity of up to 10 tons.

Precision CNC machined **28 mm** dia. horizontal and vertical holes cover the five table faces in a **100 mm** grid pattern for flexibility in the design and set-up of fixtures.

Visible grid lines on the tabletop help you align and



position your workpiece for fixturing.

All Siegmond Welding Tables feature a **plasma nitride** finish for superior surface hardness, improved load capacity, long life, and protection against weld spatter and corrosion.

Strong Hand Tools®

Better Tools. Better Price.®

Visit us online at
www.stronghandtools.com

Authorized Distributor

Customer Service

Toll Free : 800.989.5244
Tel : 562.949.8625
Fax : 562.949.4875
sales@stronghandtools.com

Address

7141 Paramount Blvd.,
Pico Rivera, CA 90660,
U.S.A.

© Copyright 2013.
All Rights Reserved.