

Hypertherm[®]

Duramax[™] and Duramax Hyamp Robotic Torches

45°, 90°, 180°



Service Manual

807460 | Revision 3 | English

Register your new Hypertherm system

Benefits of registration

- Safety:** Registration allows us to contact you in the unlikely event a safety or quality notification is required.
- Education:** Registration gives you free access to online product training content via the Hypertherm Cutting Institute.
- Confirmation of ownership:** Registration can serve as proof of purchase in case of an insurance loss.

Go to www.hypertherm.com/registration for easy and fast registration.

If you experience any problems with the product registration process, please contact registration@hypertherm.com.

For your records

Serial number: _____

Purchase date: _____

Distributor: _____

Maintenance notes: _____

Duramax, Powermax, FastConnect, and Hypertherm are trademarks of Hypertherm Inc. and may be registered in the United States and other countries. All other trademarks are the property of their respective holders.

Environmental stewardship is one of Hypertherm's core values, and it is critical to our success and our customers' success. We are striving to reduce the environmental impact of everything we do. For more information: www.hypertherm.com/environment.

Duramax /Duramax Hyamp Robotic Torches

Service Manual

807460
Revision 3

English

February 2018

Hypertherm Inc.
Hanover, NH 03755 USA
www.hypertherm.com

Hypertherm Inc.

Etna Road, P.O. Box 5010
Hanover, NH 03755 USA
603-643-3441 Tel (Main Office)
603-643-5352 Fax (All Departments)
info@hypertherm.com (Main Office Email)

800-643-9878 Tel (Technical Service)

technical.service@hypertherm.com (Technical Service Email)

800-737-2978 Tel (Customer Service)

customer.service@hypertherm.com (Customer Service Email)

866-643-7711 Tel (Return Materials Authorization)**877-371-2876 Fax (Return Materials Authorization)**

return.materials@hypertherm.com (RMA email)

Hypertherm México, S.A. de C.V.

Avenida Toluca No. 444, Anexo 1,
Colonia Olivar de los Padres
Delegación Álvaro Obregón
México, D.F. C.P. 01780
52 55 5681 8109 Tel
52 55 5683 2127 Fax
Soporte.Tecnico@hypertherm.com (Technical Service Email)

Hypertherm Plasmatechnik GmbH

Sophie-Scholl-Platz 5
63452 Hanau
Germany
00 800 33 24 97 37 Tel
00 800 49 73 73 29 Fax

31 (0) 165 596900 Tel (Technical Service)**00 800 4973 7843 Tel (Technical Service)**

technicalservice.emea@hypertherm.com (Technical Service Email)

Hypertherm (Singapore) Pte Ltd.

82 Genting Lane
Media Centre
Annexe Block #A01-01
Singapore 349567, Republic of Singapore
65 6841 2489 Tel
65 6841 2490 Fax
Marketing.asia@hypertherm.com (Marketing Email)
TechSupportAPAC@hypertherm.com (Technical Service Email)

Hypertherm Japan Ltd.

Level 9, Edobori Center Building
2-1-1 Edobori, Nishi-ku
Osaka 550-0002 Japan
81 6 6225 1183 Tel
81 6 6225 1184 Fax
HTJapan.info@hypertherm.com (Main Office Email)
TechSupportAPAC@hypertherm.com (Technical Service Email)

Hypertherm Europe B.V.

Vaartveld 9, 4704 SE
Roosendaal, Nederland
31 165 596907 Tel
31 165 596901 Fax
31 165 596908 Tel (Marketing)
31 (0) 165 596900 Tel (Technical Service)
00 800 4973 7843 Tel (Technical Service)
technicalservice.emea@hypertherm.com
(Technical Service Email)

Hypertherm (Shanghai) Trading Co., Ltd.

B301, 495 ShangZhong Road
Shanghai, 200231
PR China
86-21-80231122 Tel
86-21-80231120 Fax
86-21-80231128 Tel (Technical Service)
techsupport.china@hypertherm.com
(Technical Service Email)

South America & Central America: Hypertherm Brasil Ltda.

Rua Bras Cubas, 231 – Jardim Maia
Guarulhos, SP – Brasil
CEP 07115-030
55 11 2409 2636 Tel
tecnico.sa@hypertherm.com (Technical Service Email)

Hypertherm Korea Branch

#3904. APEC-ro 17. Heaundae-gu. Busan.
Korea 48060
82 (0)51 747 0358 Tel
82 (0)51 701 0358 Fax
Marketing.korea@hypertherm.com (Marketing Email)
TechSupportAPAC@hypertherm.com
(Technical Service Email)

Hypertherm Pty Limited

GPO Box 4836
Sydney NSW 2001, Australia
61 (0) 437 606 995 Tel
61 7 3219 9010 Fax
au.sales@Hypertherm.com (Main Office Email)
TechSupportAPAC@hypertherm.com
(Technical Service Email)

Hypertherm (India) Thermal Cutting Pvt. Ltd

A-18 / B-1 Extension,
Mohan Co-Operative Industrial Estate,
Mathura Road, New Delhi 110044, India
91-11-40521201/ 2/ 3 Tel
91-11 40521204 Fax
HTIndia.info@hypertherm.com (Main Office Email)
TechSupportAPAC@hypertherm.com
(Technical Service Email)

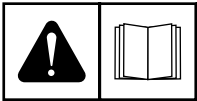

ENGLISH

WARNING! Before operating any Hypertherm equipment, read the safety instructions in your product's manual and in the *Safety and Compliance Manual* (80669C). Failure to follow safety instructions can result in personal injury or in damage to equipment.

Copies of the manuals may accompany the product in electronic and printed formats. You can also obtain copies of the manuals, in all languages available for each manual, from the "Documents library" at www.hypertherm.com.

DEUTSCH / GERMAN

WARNUNG! Bevor Sie ein Hypertherm-Gerät in Betrieb nehmen, lesen Sie bitte die Sicherheitsanweisungen in Ihrer Bedienungsanleitung sowie im *Handbuch für Sicherheit und Übereinstimmung* (80669C). Das Nichtbefolgen der Sicherheitsanweisungen kann zu Verletzungen von Personen oder Schäden am Gerät führen.

Bedienungsanleitungen und Handbücher können dem Gerät in elektronischer Form oder als Druckversion beiliegen. Alle Handbücher und Anleitungen können in den jeweils verfügbaren Sprachen auch in der „Dokumente-Bibliothek“ unter www.hypertherm.com heruntergeladen werden.

FRANÇAIS / FRENCH

AVERTISSEMENT! Avant d'utiliser tout équipement Hypertherm, lire les consignes de sécurité importantes dans le manuel de votre produit et dans le *Manuel de sécurité et de conformité* (80669C). Le non-respect des consignes de sécurité peut engendrer des blessures physiques ou des dommages à l'équipement.

Des copies de ces manuels peuvent accompagner le produit en format électronique et papier. Vous pouvez également obtenir des copies de chaque manuel dans toutes les langues disponibles à partir de la « Bibliothèque de documents » sur www.hypertherm.com.

ESPAÑOL / SPANISH

¡ADVERTENCIA! Antes de operar cualquier equipo Hypertherm, leer las instrucciones de seguridad del manual de su producto y del *Manual de Seguridad y Cumplimiento* (80669C). No cumplir las instrucciones de seguridad podría dar lugar a lesiones personales o daño a los equipos.

Pueden venir copias de los manuales en formato electrónico e impreso junto con el producto. También se pueden obtener copias de los manuales, en todos los idiomas disponibles para cada manual, de la "Biblioteca de documentos" en www.hypertherm.com.

ITALIANO / ITALIAN

AVVERTENZA! Prima di usare un'attrezzatura Hypertherm, leggere le istruzioni sulla sicurezza nel manuale del prodotto e nel *Manuale sulla sicurezza e la conformità* (80669C). Il mancato rispetto delle istruzioni sulla sicurezza può causare lesioni personali o danni all'attrezzatura.

Il prodotto può essere accompagnato da copie elettroniche e cartacee del manuale. È anche possibile ottenere copie del manuale, in tutte le lingue disponibili per ogni manuale, dall'"Archivio documenti" all'indirizzo www.hypertherm.com.

NEDERLANDS / DUTCH

WAARSCHUWING! Lees voordat u Hypertherm-apparatuur gebruikt de veiligheidsinstructies in de producthandleiding en in de *Veiligheids- en nalevingshandleiding* (80669C). Het niet volgen van de veiligheidsinstructies kan resulteren in persoonlijk letsel of schade aan apparatuur.

De handleidingen kunnen in elektronische en gedrukte vorm met het product worden meegeleverd. De handleidingen, elke handleiding beschikbaar in alle talen, zijn ook verkrijgbaar via de "Documentenbibliotheek" op www.hypertherm.com.

DANSK / DANISH

ADVARSEL! Inden Hypertherm udstyr tages i brug skal sikkerhedsinstruktionerne i produktets manual og i *Manual om sikkerhed og overholdelse af krav* (80669C), gennelæses. Følges sikkerhedsvejledningen ikke kan det resultere i personskade eller beskadigelse af udstyret.

Kopier af manualerne kan ledsage produktet i elektroniske og trykte formater. Du kan også få kopier af manualer, på alle sprog der er til rådighed for hver manuel, fra "Dokumentbiblioteket" på www.hypertherm.com.

PORTUGUÊS / PORTUGUESE

AVERTÊNCIA! Antes de operar qualquer equipamento Hypertherm, leia as instruções de segurança no manual do seu produto e no *Manual de Segurança e de Conformidade* (80669C). Não seguir as instruções de segurança pode resultar em lesões corporais ou danos ao equipamento.

Cópias dos manuais podem acompanhar os produtos nos formatos eletrônico e impresso. Também é possível obter cópias dos manuais em todos os idiomas disponíveis para cada manual na "Biblioteca de documentos" em www.hypertherm.com.

日本語 / JAPANESE

警告! Hypertherm 機器を操作する前に、安全に関する重要な情報について、この製品説明書にある安全情報、および製品に同梱されている別冊の「安全とコンプライアンスマニュアル」(80669C)をお読みください。安全情報に従わないと怪我や装置の損傷を招くことがあります。

説明書のコピーは、電子フォーマット、または印刷物として製品に同梱されています。各説明書は、www.hypertherm.com の「ドキュメントライブラリ」から各言語で入手できます。

简体中文 / CHINESE (SIMPLIFIED)

警告! 在操作任何海宝设备之前, 请阅读产品手册和《安全和法规遵守手册》(80669C) 中的安全操作说明。若未能遵循安全操作说明, 可能会造成人员受伤或设备损坏。

随产品提供的手册可能提供电子版和印刷版两种格式。您也可从 "Documents library" (文档资料库) 中获取每本手册所有可用语言的副本, 网址为 www.hypertherm.com。

NORSK / NORWEGIAN

ADVARSEL! Før du bruker noe Hypertherm-utstyr, må du lese sikkerhetsinstruksjonene i produktets håndbok og i *Håndboken om sikkerhet og samsvar* (80669C). Unnlattelse av å følge sikkerhetsinstruksjoner kan føre til personskade eller skade på utstyr.

Eksemplarer av håndbøkene kan medfølge produktet i elektroniske og trykte utgaver. Du kan også få eksemplarer av håndbøkene i alle tilgjengelige språk for hver håndbok fra dokumentbiblioteket på www.hypertherm.com.

SVENSKA / SWEDISH

VARNING! Läs häftet *säkerhetsinformationen i din produkts säkerhets- och efterlevnadsmanual* (80669C) för viktig säkerhetsinformation innan du använder eller underhåller Hypertherm-utrustning. Underlåtenhet att följa dessa säkerhetsinstruktioner kan resultera i personskador eller skador på utrustningen.

Kopior av manualen kan medfölja produkten i elektronisk och tryckform. Du hittar även kopior av manualerna i alla tillgängliga språk i dokumentbiblioteket (Documents library) på www.hypertherm.com.

한국어 / KOREAN

경고! Hypertherm 장비를 사용하기 전에 제품 설명서와 안전 및 규정 준수 설명서 (80669C)에 나와 있는 안전 지침을 읽으십시오. 안전 지침을 준수하지 않으면 신체 부상이나 장비 손상을 초래할 수 있습니다.

전자 형식과 인쇄된 형식으로 설명서 사본이 제품과 함께 제공될 수 있습니다. www.hypertherm.com 의 'Documents library (문서 라이브러리)' 에서도 모든 언어로 이용할 수 있는 설명서 사본을 얻을 수 있습니다.

ČESKY / CZECH

VAROVÁNÍ! Před uvedením jakéhokoliv zařízení Hypertherm do provozu si přečtěte bezpečnostní pokyny v příručce k produktu a v *Manuálu pro bezpečnost a dodržování předpisů* (80669C). Nedodržování bezpečnostních pokynů může mít za následek zranění osob nebo poškození majetku.

Kopie příruček a manuálů mohou být součástí dodávky produktu, a to v elektronické i tištěné formě. Kopie příruček a manuálů ve všech jazykových verzích, v nichž byly dané příručky a manuály vytvořeny, naleznete v „Knihovně dokumentů“ na webových stránkách www.hypertherm.com.

POLSKI / POLISH

OSTRZEŻENIE! Przed rozpoczęciem obsługi jakiegokolwiek systemu firmy Hypertherm należy się zapoznać z instrukcjami bezpieczeństwa zamieszczonymi w podręczniku produktu oraz w *Podręczniku bezpieczeństwa i zgodności* (80669C). Nieprzestrzeganie instrukcji bezpieczeństwa może skutkować obrażeniami ciała i uszkodzeniem sprzętu.

Do produktu mogą być dołączone kopie podręczników w formie elektronicznej i drukowanej. Kopie podręczników, w każdym udostępnionym języku, można również znaleźć w „Bibliotece dokumentów” pod adresem www.hypertherm.com.

РУССКИЙ / RUSSIAN

БЕРЕГИСЬ! Перед работой с любым оборудованием Hypertherm ознакомьтесь с инструкциями по безопасности, представленными в руководстве, которое поставляется вместе с продуктом, а также в *Руководстве по безопасности и соответствию* (80669J). Невыполнение инструкций по безопасности может привести к телесным повреждениям или повреждению оборудования.

Копии руководств, которые поставляются вместе с продуктом, могут быть представлены в электронном и бумажном виде. Копии руководств на всех языках, на которые переведено то или иное руководство, можно также загрузить в разделе «Библиотека документов» на веб-сайте www.hypertherm.com.

SUOMI / FINNISH

VAROITUS! Ennen minkään Hypertherm-laitteen käyttöä lue tuotteen käyttöoppaassa olevat turvallisuusohjeet ja *turvallisuus- ja vaatimustenmukaisuusohje* (80669C). Turvallisuusohjeiden laiminlyönti voi aiheuttaa henkilökohtaisen loukkaantumisen tai laitevahingon.

Käyttöoppaiden kopiot voivat olla tuotteen mukana elektronisessa ja tulostetussa muodossa. Voit saada käyttöoppaiden kopiot kaikilla kielillä ”latauskirjastosta”, joka on osoitteessa www.hypertherm.com.

БЪЛГАРСКИ / BULGARIAN

ПРЕДУПРЕЖДЕНИЕ! Преди да работите с което и да е оборудване Hypertherm, прочетете инструкциите за безопасност в ръководството на вашия продукт и „Инструкция за безопасност и съответствие“ (80669C). Неспазването на инструкциите за безопасност би могло да доведе до телесно нараняване или до повреда на оборудването.

Копия на ръководствата може да придружават продукта в електронен и в печатен формат. Можете да получите копия на ръководствата, предлагани на всички езици, от „Documents library“ (Библиотека за документи) на адрес www.hypertherm.com.

ROMÂNĂ / ROMANIAN

AVERTIZARE! Înainte de utilizarea oricărui echipament Hypertherm, citiți instrucțiunile de siguranță din cadrul manualului produsului și din cadrul *Manualului de siguranță și conformitate* (80669C). Nerespectarea instrucțiilor de siguranță pot rezulta în vătămare personală sau în avarierea echipamentului.

Produsul poate fi însoțit de copii ale manualului în format tipărit și electronic. De asemenea, dumneavoastră puteți obține copii ale manualelor, în toate limbile disponibile pentru fiecare manual, din cadrul secțiunii „Biblioteca documente” afiată pe site-ul www.hypertherm.com.

TÜRKÇE / TURKISH

UYARI! Bir Hypertherm ekipmanını çalıştırmadan önce, ürün kullanım kılavuzunda ve *Güvenlik ve Uyumluluk Kılavuzu'nda* (80669C) yer alan güvenlik talimatlarını okuyun. Güvenlik talimatlarına uyulmaması durumunda kişisel yaralanmalar veya ekipman hasarı meydana gelebilir.

Kılavuzların kopyaları, elektronik ve basılı formatta ürünle birlikte verilebilir. Her biri tüm dillerde yayınlanan kılavuzların kopyalarını www.hypertherm.com adresindeki “Documents library” (Dosyalar kitaplığı) başlığından da elde edebilirsiniz.

MAGYAR / HUNGARIAN

VIGYÁZAT! Mielőtt bármilyen Hypertherm berendezést üzemeltetne, olvassa el a biztonsági információkat a termék kézikönyvében és a *Biztonsági és szabálykövetési kézikönyvben* (80669C). A biztonsági utasítások betartásának elmulasztása személyi sérüléshez vagy a berendezés károsodásához vezethet.

A termékhez a kézikönyv példányai elektronikus és nyomtatott formában is mellékelve lehetnek. A kézikönyvek példányai (minden nyelven) a www.hypertherm.com weboldalon a „Documents library” (Dokumentum könyvtár) részben is beszerezhető.

ΕΛΛΗΝΙΚΑ / GREEK

ΠΡΟΕΙΔΟΠΟΙΗΣΗ! Πριν θέσετε σε λειτουργία οποιοδήποτε εξοπλισμό της Hypertherm, διαβάστε τις οδηγίες ασφαλείας στο εγχειρίδιο του προϊόντος και στο *Εγχειρίδιο ασφαλείας και συμμόρφωσης* (80669C). Η μη τήρηση των οδηγιών ασφαλείας μπορεί να επιφέρει σωματική βλάβη ή ζημία στον εξοπλισμό.

Αντίγραφα των εγχειριδίων μπορεί να συνοδεύουν το προϊόν σε ηλεκτρονική και έντυπη μορφή. Μπορείτε, επίσης, να λάβετε αντίγραφα των εγχειριδίων σε όλες τις γλώσσες που διατίθενται για κάθε εγχειρίδιο από την ψηφιακή βιβλιοθήκη εγγράφων (Documents library) στη διαδικτυακή τοποθεσία www.hypertherm.com.

繁體中文 / CHINESE (TRADITIONAL)

警告！在操作任何 Hypertherm 設備前，請閱讀您產品手冊和《安全和法務遵從手冊》(80669C) 內的安全指示。不遵守安全指示可能會導致人身傷害或設備損壞。

手冊複本可能以電子和印刷格式隨附產品提供。您也可以從 www.hypertherm.com 的「文檔資料庫」內獲取所有手冊的多語種複本。

SLOVENŠČINA / SLOVENIAN

OPOZORILO! Pred uporabo katerekoli Hyperthermove opreme preberite varnostna navodila v priročniku vašega izdelka ter v *Priročniku za varnost in skladnost* (80669C). Neupoštevanje navodil za uporabo lahko povzroči telesne poškodbe ali materialno škodo.

Izdelku so lahko priloženi izvodi priročnikov v elektronski ali tiskani obliki. Izvode priročnikov v vseh razpoložljivih jezikih si lahko prenesete tudi iz knjižnice dokumentov “Documents library” na naslovu www.hypertherm.com.

SRPSKI / SERBIAN

UPOZORENJE! Pre rukovanja bilo kojom Hyperthermovom opremom pročitajte uputstva o bezbednosti u svom priručniku za proizvod i u *Priručniku o bezbednosti i usaglašenosti* (80669C). Oglašavanje o praćenje uputstava o bezbednosti može da ima za posledicu ličnu povredu ili oštećenje opreme.

Može se dogoditi da kopije priručnika prate proizvod u elektronskom i štampanom formatu. Takođe možete da pronađete kopije priručnika, na svim jezicima koji su dostupni za svaki od priručnika, u “Biblioteci dokumenata” (“Documents library”) na www.hypertherm.com.

SLOVENČINA / SLOVAK

VÝSTRAHA! Pred použitím akéhokoľvek zariadenia od spoločnosti Hypertherm si prečítajte bezpečnostné pokyny v návode na obsluhu vášho zariadenia a v *Manuáli o bezpečnosti a súlade s normami* (80669C). V prípade nedodržania bezpečnostných pokynov môže dôjsť k ujme na zdraví alebo poškodeniu zariadenia.

Kópia návodu, ktorá je dodávaná s produktom, môže mať elektronickú alebo tlačенú podobu. Kópie návodov, vo všetkých dostupných jazykoch, sú k dispozícii aj v sekcii z „knihnice Dokumenty“ na www.hypertherm.com.

Electromagnetic Compatibility (EMC)	SC-11
Introduction	SC-11
Installation and use	SC-11
Assessment of area	SC-11
Methods of reducing emissions	SC-11
Mains supply	SC-11
Maintenance of cutting equipment	SC-11
Cutting cables	SC-11
Equipotential bonding	SC-11
Earthing of the workpiece	SC-12
Screening and shielding	SC-12
Warranty	SC-13
Attention	SC-13
General	SC-13
Patent indemnity	SC-13
Limitation of liability	SC-13
National and local codes	SC-13
Liability cap	SC-14
Insurance	SC-14
Transfer of rights	SC-14
Waterjet product warranty coverage	SC-14
Product	SC-14
Parts coverage	SC-14
1 Specifications	15
Introduction	15
Duramax component weights	16

Duramax Hyamp component weights	16
Torch dimensions	17
Duramax 180° robotic torch dimensions	17
Duramax 90° robotic torch dimensions	17
Duramax 45° robotic torch dimensions	18
Duramax Hyamp 180° robotic torch dimensions	18
Duramax Hyamp 90° robotic torch dimensions	19
Duramax Hyamp 45° robotic torch dimensions	19
2 Torch Setup	21
Robotic torch components	21
Install the torch	22
Disassemble the robotic torch	23
Mount the torch	30
Consumable life	33
Choosing the consumables	34
Duramax robotic torches	34
Duramax consumables	34
Duramax mechanized shielded higher amperages*	34
Duramax mechanized shielded lower amperages*	34
Duramax FineCut shielded*	35
*Ohmic-sensing retaining cap	35
Duramax mechanized unshielded higher amperages	35
Duramax mechanized unshielded lower amperages	36
Duramax FineCut unshielded	36
Duramax Hyamp robotic torches	37
Duramax Hyamp consumables	37
Duramax Hyamp mechanized shielded higher amperages*	37
Duramax Hyamp mechanized shielded lower amperages *	37
Duramax Hyamp FineCut shielded*	37
*Ohmic-sensing retaining cap	37
Installing the consumables	38
Connecting the torch lead	39
Connecting a remote-start pendant	40
Connecting the machine interface cable	41
Machine interface pinout	43
Setting the five-position voltage divider	45
Using the cut charts	46

- 3 Operation 47**
 - Using the robotic torch 47
 - Using the robotic teach tool 48
 - Understand and optimize cut quality 49
 - Cut or bevel angle 49
 - Dross 49
 - Straightness of the cut surface 50
 - Piercing a workpiece using the robotic torch 50
 - Common machine-cutting faults 51

- 4 Component Replacement 53**
 - Duramax and Duramax Hyamp robotic torch overview 53
 - Disconnect the power, gas supply, and torch 55
 - Replacing the positioning barrel 56
 - Replacing the torch body 59
 - Replacing the cap-sensor switch 61
 - Replacing the torch lead 62

- 5 Maintenance and Parts 65**
 - Perform routine maintenance 65
 - Routine maintenance tasks 66
 - Inspect the consumables 67
 - Duramax robotic torch replacement parts 68
 - Duramax 180° robotic torch 68
 - Duramax 90° robotic torch 69
 - Duramax 45° robotic torch 70
 - Duramax Hyamp robotic torch replacement parts 71
 - Duramax Hyamp 180° robotic torch 71
 - Duramax Hyamp 90° robotic torch 72
 - Duramax Hyamp 45° robotic torch 73
 - Accessory parts 74

Introduction

Hypertherm's CE-marked equipment is built in compliance with standard EN60974-10. The equipment should be installed and used in accordance with the information below to achieve electromagnetic compatibility.

The limits required by EN60974-10 may not be adequate to completely eliminate interference when the affected equipment is in close proximity or has a high degree of sensitivity. In such cases it may be necessary to use other measures to further reduce interference.

This cutting equipment is designed for use only in an industrial environment.

Installation and use

The user is responsible for installing and using the plasma equipment according to the manufacturer's instructions.

If electromagnetic disturbances are detected then it shall be the responsibility of the user to resolve the situation with the technical assistance of the manufacturer. In some cases this remedial action may be as simple as earthing the cutting circuit, see *Earthing of the workpiece*. In other cases, it could involve constructing an electromagnetic screen enclosing the power source and the work complete with associated input filters. In all cases, electromagnetic disturbances must be reduced to the point where they are no longer troublesome.

Assessment of area

Before installing the equipment, the user shall make an assessment of potential electromagnetic problems in the surrounding area. The following shall be taken into account:

- a. Other supply cables, control cables, signaling and telephone cables; above, below and adjacent to the cutting equipment.
- b. Radio and television transmitters and receivers.
- c. Computer and other control equipment.
- d. Safety critical equipment, for example guarding of industrial equipment.
- e. Health of the people around, for example the use of pacemakers and hearing aids.
- f. Equipment used for calibration or measurement.
- g. Immunity of other equipment in the environment. User shall ensure that other equipment being used in the environment is compatible. This may require additional protection measures.
- h. Time of day that cutting or other activities are to be carried out.

The size of the surrounding area to be considered will depend on the structure of the building and other activities that are taking place. The surrounding area may extend beyond the boundaries of the premises.

Methods of reducing emissions

Mains supply

Cutting equipment must be connected to the mains supply according to the manufacturer's recommendations. If interference occurs, it may be necessary to take additional precautions such as filtering of the mains supply.

Consideration should be given to shielding the supply cable of permanently installed cutting equipment, in metallic conduit or equivalent. Shielding should be electrically continuous throughout its length. The shielding should be connected to the cutting mains supply so that good electrical contact is maintained between the conduit and the cutting power source enclosure.

Maintenance of cutting equipment

The cutting equipment must be routinely maintained according to the manufacturer's recommendations. All access and service doors and covers should be closed and properly fastened when the cutting equipment is in operation. The cutting equipment should not be modified in any way, except as set forth in and in accordance with the manufacturer's written instructions. For example, the spark gaps of arc striking and stabilizing devices should be adjusted and maintained according to the manufacturer's recommendations.

Cutting cables

The cutting cables should be kept as short as possible and should be positioned close together, running at or close to the floor level.

Equipotential bonding

Bonding of all metallic components in the cutting installation and adjacent to it should be considered.

However, metallic components bonded to the workpiece will increase the risk that the operator could receive a shock by touching these metallic components and the electrode (nozzle for laser heads) at the same time.

The operator should be insulated from all such bonded metallic components.

Electromagnetic Compatibility (EMC)

Earthing of the workpiece

Where the workpiece is not bonded to earth for electrical safety, nor connected to earth because of its size and position, for example, ship's hull or building steel work, a connection bonding the workpiece to earth may reduce emissions in some, but not all instances. Care should be taken to prevent the earthing of the workpiece increasing the risk of injury to users, or damage to other electrical equipment. Where necessary, the connection of the workpiece to earth should be made by a direct connection to the workpiece, but in some countries where direct connection is not permitted, the bonding should be achieved by suitable capacitances selected according to national regulations.

Note: The cutting circuit may or may not be earthed for safety reasons. Changing the earthing arrangements should only be authorized by a person who is competent to assess whether the changes will increase the risk of injury, for example, by allowing parallel cutting current return paths which may damage the earth circuits of other equipment. Further guidance is provided in IEC 60974-9, Arc Welding Equipment, Part 9: Installation and Use.

Screening and shielding

Selective screening and shielding of other cables and equipment in the surrounding area may alleviate problems of interference. Screening of the entire plasma cutting installation may be considered for special applications.

Attention

Genuine Hypertherm parts are the factory-recommended replacement parts for your Hypertherm system. Any damage or injury caused by the use of other than genuine Hypertherm parts may not be covered by the Hypertherm warranty, and will constitute misuse of the Hypertherm Product.

You are solely responsible for the safe use of the Product. Hypertherm does not and cannot make any guarantee or warranty regarding the safe use of the product in your environment.

General

Hypertherm Inc. warrants that its Products shall be free from defects in materials and workmanship for the specific periods of time set forth herein and as follows: if Hypertherm is notified of a defect (i) with respect to the plasma power supply within a period of two (2) years from the date of its delivery to you, with the exception of Powermax brand power supplies, which shall be within a period of three (3) years from the date of delivery to you, and (ii) with respect to the torch and leads within a period of one (1) year from its date of delivery to you, with the exception of the HPRXD short torch with integrated lead, which shall be within a period of six (6) months from the date of delivery to you, and with respect to torch lifter assemblies within a period of one (1) year from its date of delivery to you, and with respect to Automation products one (1) year from its date of delivery to you, with the exception of the EDGE Connect CNC, EDGE Connect T CNC, EDGE Connect TC CNC, EDGE Pro CNC, EDGE Pro Ti CNC, MicroEDGE Pro CNC, and ArcGlide THC, which shall be within a period of two (2) years from the date of delivery to you, and (iii) with respect to HyIntensity fiber laser components within a period of two (2) years from the date of its delivery to you, with the exception of laser heads and beam delivery cables, which shall be within a period of one (1) year from its date of delivery to you.

This warranty shall not apply to any Powermax brand power supplies that have been used with phase converters. In addition, Hypertherm does not warranty systems that have been damaged as a result of poor power quality, whether from phase converters or incoming line power. This warranty shall not apply to any product which has been incorrectly installed, modified, or otherwise damaged.

Hypertherm provides repair, replacement or adjustment of the Product as the sole and exclusive remedy, if and only if the warranty set forth herein properly is invoked and applies. Hypertherm, at its sole option, shall repair, replace, or adjust, free of charge, any defective Products covered by this warranty which shall be returned with Hypertherm's prior authorization (which shall not be unreasonably withheld), properly packed, to Hypertherm's place of business in Hanover, New Hampshire, or to an authorized Hypertherm repair facility, all costs, insurance and freight pre paid by the customer. Hypertherm shall not be liable for any repairs, replacement, or adjustments of Products covered by this warranty, except those made pursuant to this paragraph and with Hypertherm's prior written consent.

The warranty set forth above is exclusive and is in lieu of all other warranties, express, implied, statutory, or otherwise with respect to the Products or as to the results which may be obtained therefrom, and all implied warranties or conditions of quality or of merchantability or fitness for a particular purpose or against infringement. The foregoing shall constitute the sole and exclusive remedy for any breach by Hypertherm of its warranty.

Distributors/OEMs may offer different or additional warranties, but Distributors/OEMs are not authorized to give any additional warranty protection to you or make any representation to you purporting to be binding upon Hypertherm.

Patent indemnity

Except only in cases of products not manufactured by Hypertherm or manufactured by a person other than Hypertherm not in strict conformity with Hypertherm's specifications and in cases of designs, processes, formulae, or combinations not developed or purported to be developed by Hypertherm, Hypertherm will have the right to defend or settle, at its own expense, any suit or proceeding brought against you alleging that the use of the Hypertherm product, alone and not in combination with any other product not supplied by Hypertherm, infringes any patent of any third party. You shall notify Hypertherm promptly upon learning of any action or threatened action in connection with any such alleged infringement (and in any event no longer than fourteen (14) days after learning of any action or threat of action), and Hypertherm's obligation to defend shall be conditioned upon Hypertherm's sole control of, and the indemnified party's cooperation and assistance in, the defense of the claim.

Limitation of liability

In no event shall Hypertherm be liable to any person or entity for any incidental, consequential direct, indirect, punitive or exemplary damages (including but not limited to lost profits) regardless of whether such liability is based on breach of contract, tort, strict liability, breach of warranty, failure of essential purpose, or otherwise, and even if advised of the possibility of such damages. Hypertherm shall not be liable for any losses to Distributor based on down time, lost production or lost profits. It is the intention of the Distributor and Hypertherm that this provision be construed by a court as being the broadest limitation of liability consistent with applicable law.

National and local codes

National and local codes governing plumbing and electrical installation shall take precedence over any instructions contained in this manual. In no event shall Hypertherm be liable for injury to persons or property damage by reason of any code violation or poor work practices.

Warranty

Liability cap

In no event shall Hypertherm's liability, if any, whether such liability is based on breach of contract, tort, strict liability, breach of warranties, failure of essential purpose or otherwise, for any claim, action, suit or proceeding (whether in court, arbitration, regulatory proceeding or otherwise) arising out of or relating to the use of the Products exceed in the aggregate the amount paid for the Products that gave rise to such claim.

Insurance

At all times you will have and maintain insurance in such quantities and types, and with coverage sufficient and appropriate to defend and to hold Hypertherm harmless in the event of any cause of action arising from the use of the products.

Transfer of rights

You may transfer any remaining rights you may have hereunder only in connection with the sale of all or substantially all of your assets or capital stock to a successor in interest who agrees to be bound by all of the terms and conditions of this Warranty. Within thirty (30) days before any such transfer occurs, you agree to notify in writing Hypertherm, which reserves the right of approval. Should you fail timely to notify Hypertherm and seek its approval as set forth herein, the Warranty set forth herein shall be null and void and you will have no further recourse against Hypertherm under the Warranty or otherwise.

Waterjet product warranty coverage

Product	Parts coverage
HyPrecision pumps	27 months from the ship date, or 24 months from the date of proven installation, or 4,000 hours, whichever occurs first
PowerDredge abrasive removal system	15 months from the ship date or 12 months from the date of proven installation, whichever occurs first
EcoSift abrasive recycling system	15 months from the ship date or 12 months from the date of proven installation, whichever occurs first
Abrasive metering devices	15 months from the ship date or 12 months from the date of proven installation, whichever occurs first
On/off valve air actuators	15 months from the ship date or 12 months from the date of proven installation, whichever occurs first
Diamond orifices	600 hours of use with the use of a thimble filter and compliance with Hypertherm's water quality requirements

Consumable parts are not covered by this warranty. Consumable parts include, but are not limited to, high-pressure water seals, check valves, cylinders, bleed-down valves, low-pressure seals, high-pressure tubing, low- and high-pressure water filters and abrasive collection bags. All third-party pumps, pump accessories, hoppers, hopper accessories, dryer boxes, dryer box accessories and plumbing accessories are covered by the respective manufacturers' warranties and not covered by this warranty.

Introduction

The Duramax robotic torch line consists of 3 torches: 180°, 90°, and 45°, designed for use with the Powermax65®, Powermax85, and Powermax105 systems. These torches are also compatible with the Powermax45 and Powermax45 XP systems. The Duramax robotic torches are not compatible with the Powermax125 system. These torches use only Duramax consumables.

The Duramax Hyamp robotic torch line also consists of 3 torches: 180°, 90°, and 45°, designed for use with the Powermax125 systems. These torches are also compatible with the Powermax45 XP, Powermax65, Powermax85, and Powermax105 systems. These torches use only Duramax Hyamp consumables.

Both lines of torches are designed for use in robotic applications. They can also be used in other mechanized applications where careful positioning of the torch and the ability to approach the workpiece at an angle are important considerations.

The FastConnect™ quick-disconnect system makes it easy to remove the torch for transport or to switch from one torch to the other if your applications require the use of different torches. The torches are cooled by ambient air and do not require special cooling procedures.

Duramax and Duramax Hyamp robotic torches comply with IEC 60974-7 and are not suitable for use in the rain or snow.

1 – Specifications

Duramax component weights

Duramax robotic torch with 7.6 m (25 foot) lead	3.3 kg (7.2 pounds)
Duramax robotic torch with 15 m (50 foot) lead	5.7 kg (12.5 pounds)

 The recommended minimum bend radius for the Duramax torch lead is 76 mm (3.0 inches). See *Figure 1*.

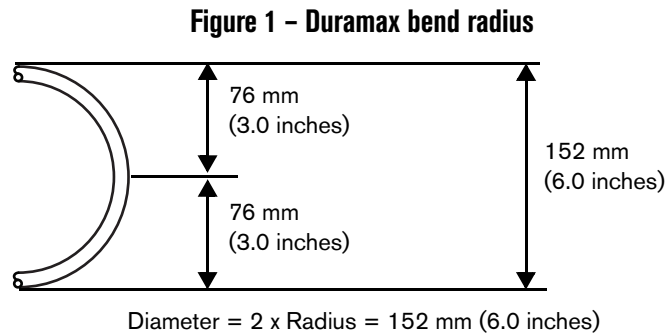

Duramax Hyamp component weights

Duramax Hyamp robotic torch with 7.6 m (25 foot) lead	3.5 kg (7.8 pounds)
Duramax Hyamp robotic torch with 15 m (50 foot) lead	6.6 kg (14.6 pounds)

 The recommended minimum bend radius for the Duramax Hyamp torch lead is 102 mm (4.0 inches). See *Figure 2*.

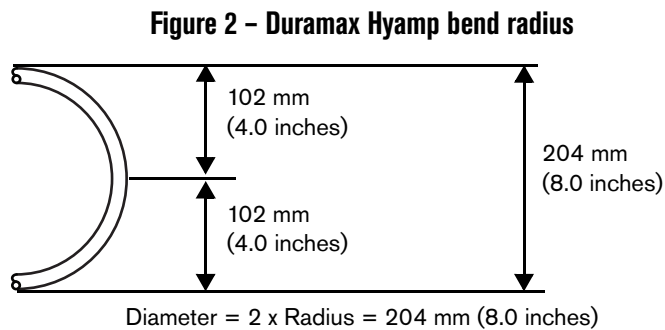

Torch dimensions

Duramax 180° robotic torch dimensions

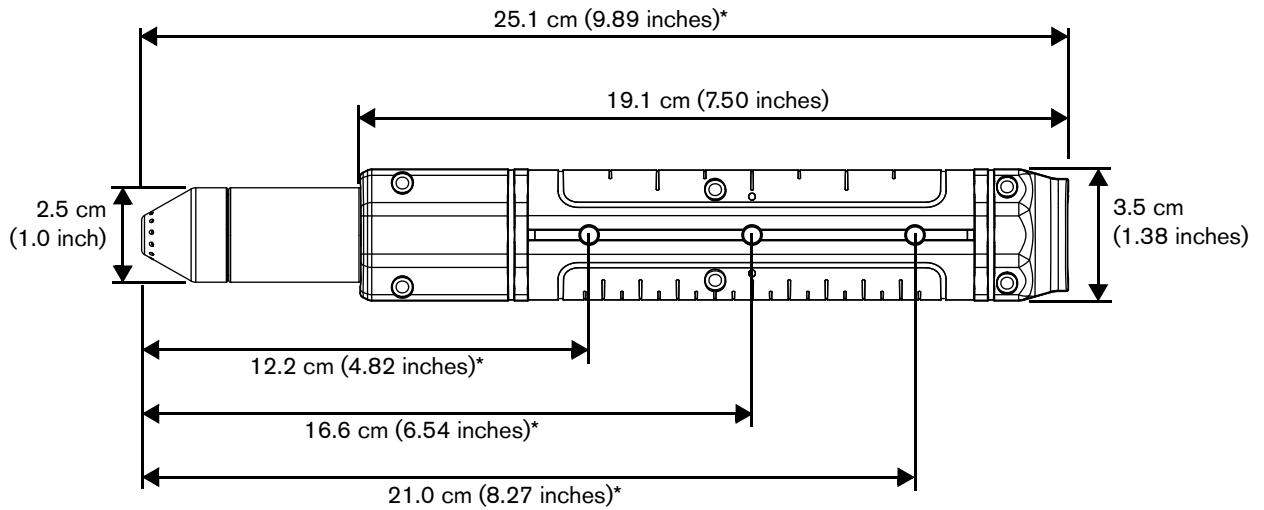

Duramax 90° robotic torch dimensions

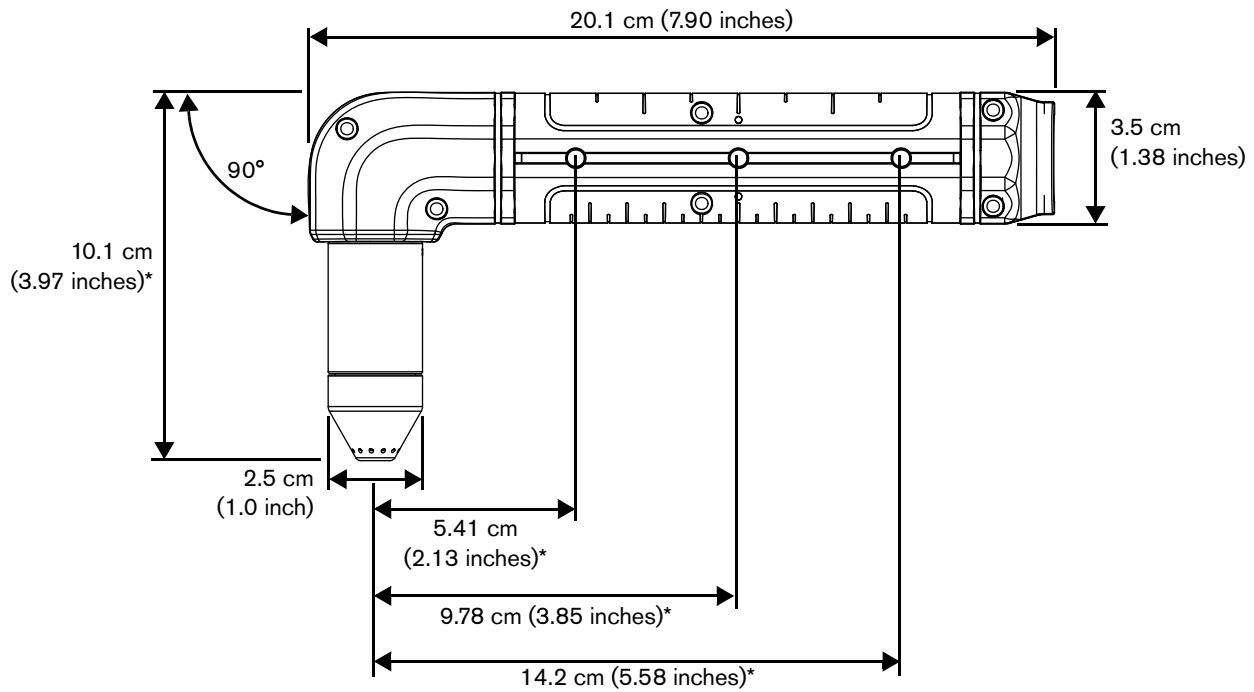

1 – Specifications

Duramax 45° robotic torch dimensions

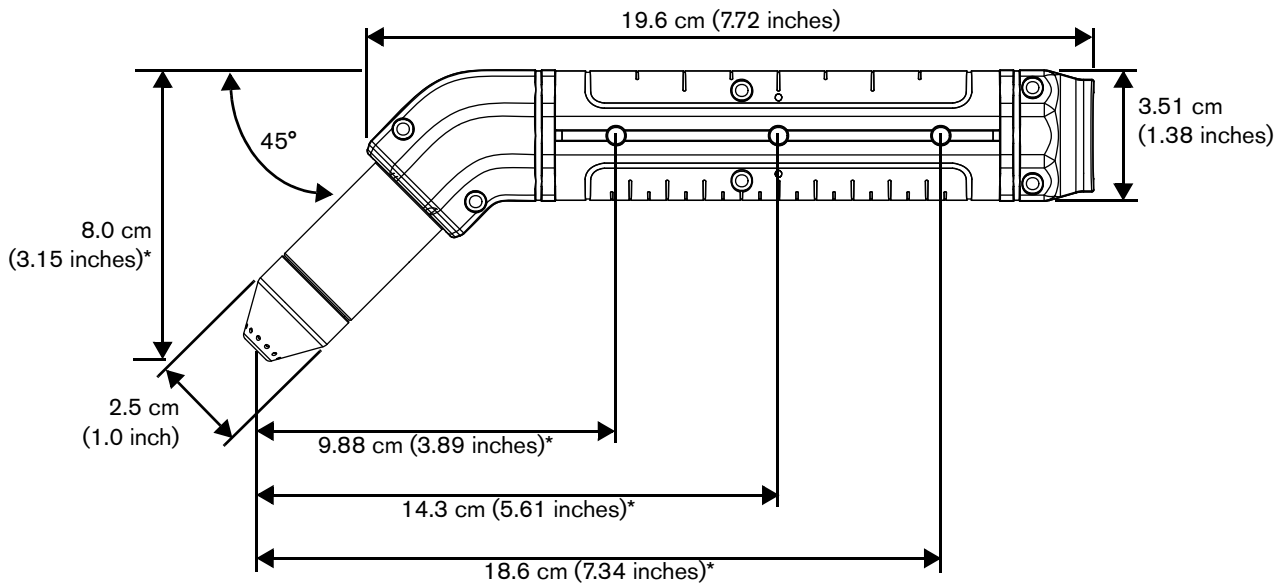

Duramax Hyamp 180° robotic torch dimensions

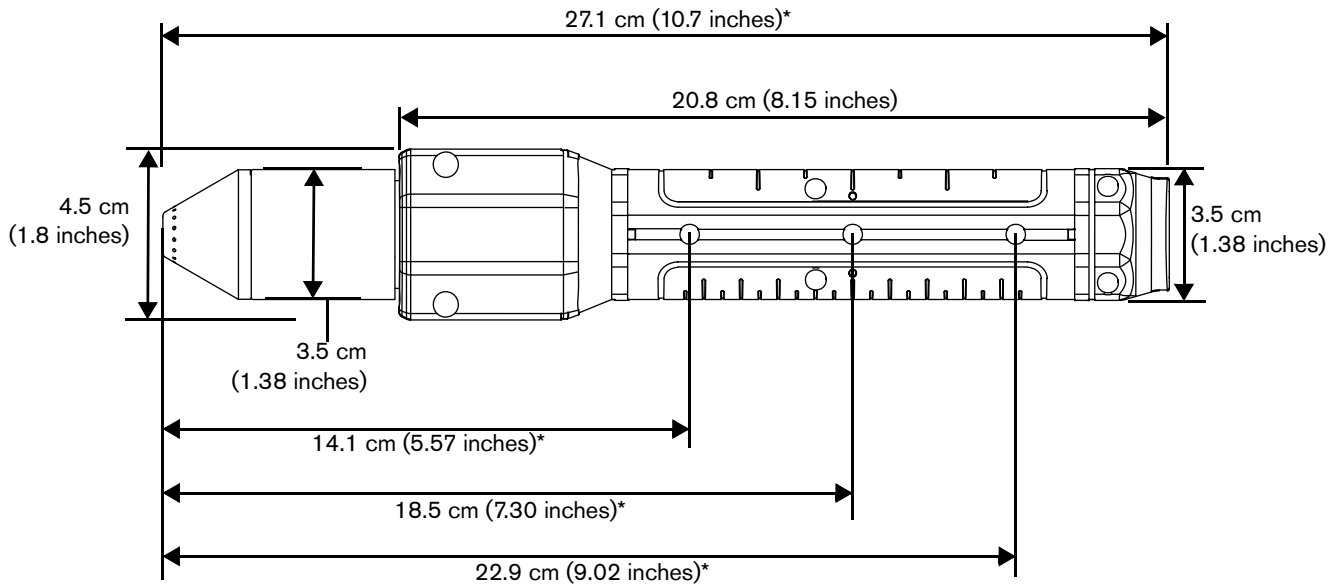

Duramax Hyamp 90° robotic torch dimensions

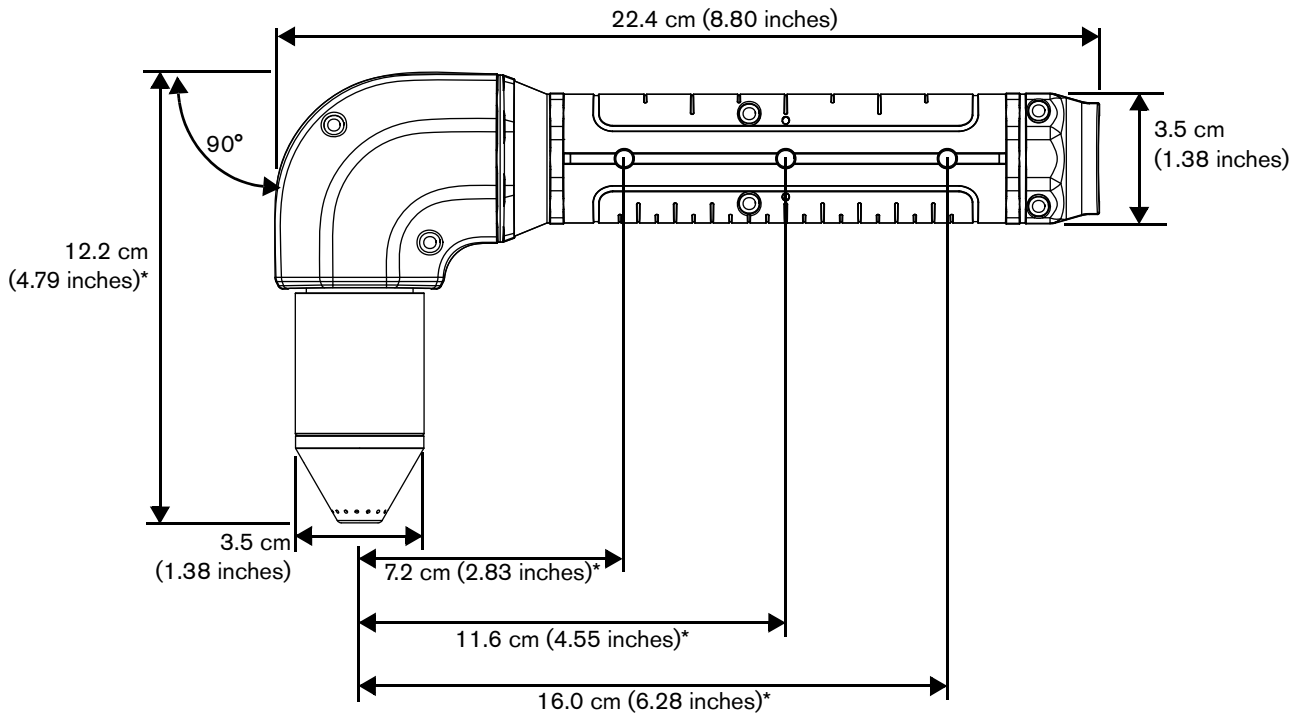

Duramax Hyamp 45° robotic torch dimensions

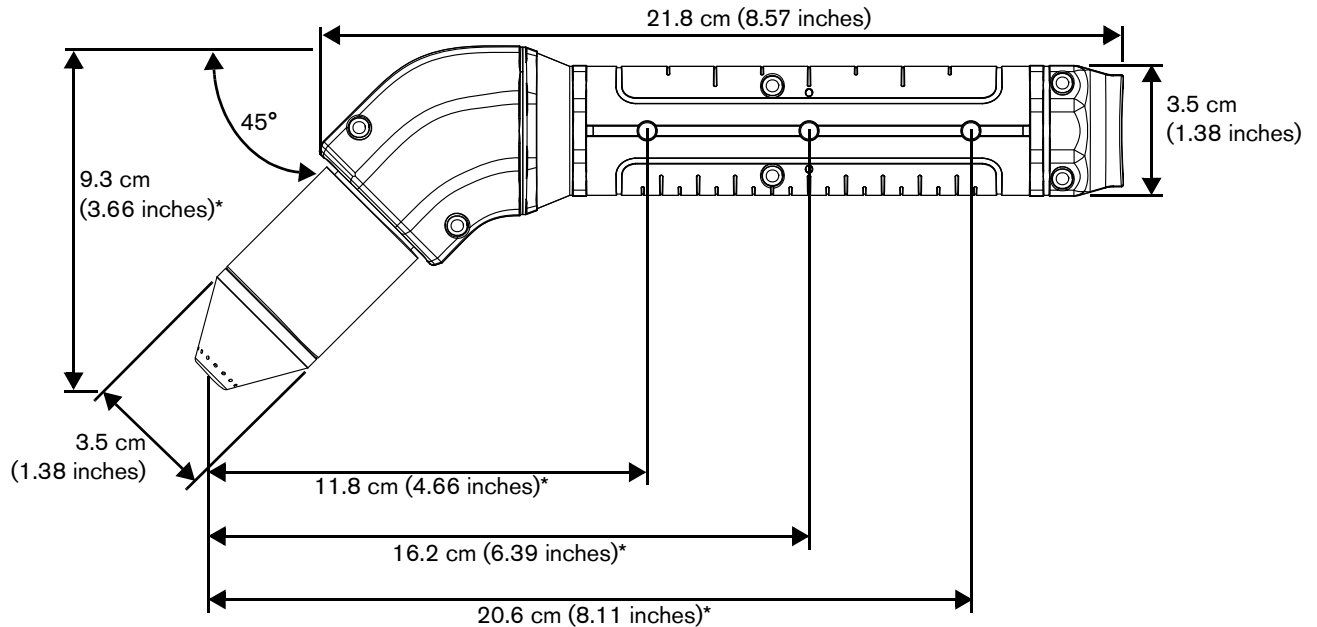

* Torch dimensions will vary depending on the type of consumables installed. The preceding figures show the mechanized shielded consumables installed.

Robotic torch components

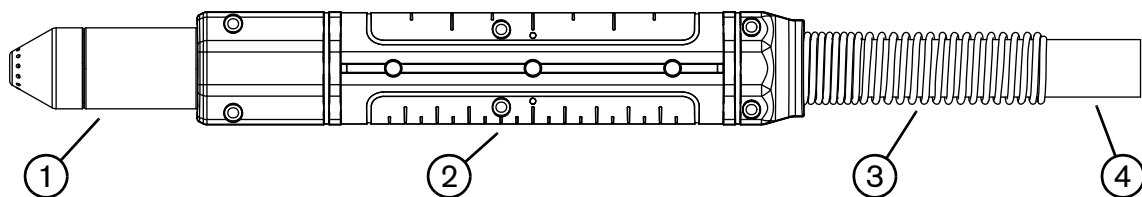

- 1 Consumables
- 2 Positioning barrel

- 3 Strain relief
- 4 Torch lead

 Duramax 180° is shown.

Before using any robotic torch, you must:

- Install and mount the torch.
- Choose and install the consumables.
- Attach the torch lead to the power supply.
- Set up the power supply for remote starting with either the remote-start pendant or a machine interface cable.

Install the torch

Depending on the type of torch, robot, and installation method, you may need to disassemble the FastConnect plug or torch to install the torch. For the outside mounting method, it is not necessary to disassemble the torch. The torch can be mounted per the instructions in *Mount the torch* on page 30.

For the through-arm mounting method, see *Figure 3* to determine if the robot's through-arm cavity is large enough to accept the torch lead's FastConnect plug as assembled or with the 2 shells removed. If the through-arm cavity is large enough for the FastConnect plug as assembled, route the torch lead through the through-arm cavity. Then, mount the torch to the robot arm per the instructions in *Mount the torch* on page 30.

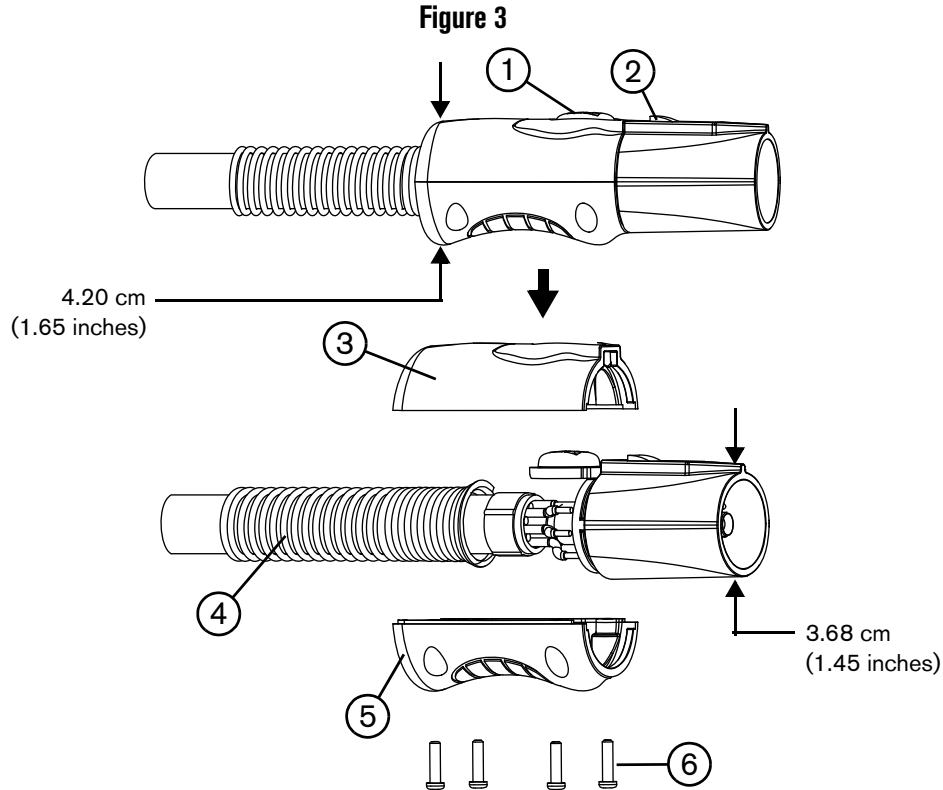

- 1 Disconnect button
- 2 Tab
- 3 Top shell

- 4 Strain relief
- 5 Bottom shell
- 6 Mounting screws (4)

If the through-arm cavity is large enough for the disassembled FastConnect plug (see *Figure 3* for dimensions), complete the following instructions.



1. Remove the mounting screws from the bottom shell and pull the 2 shells apart.

 The red disconnect button and tab on top of the FastConnect plug are spring loaded and self-adjust below the surface of the plug while being routed through the through-arm cavity.

2. Cover the end of the FastConnect plug with tape to keep dirt and other contaminants from getting into the gas line.
3. Route the torch lead through the through-arm cavity.
4. Install the 2 shells by aligning them over the torch lead, making sure the strain relief is held in place by the slot in the FastConnect shells.
5. Tighten the mounting screws.
6. Mount the torch to the robot arm per the instructions in *Mount the torch* on page 30.

Disassemble the robotic torch

If the through-arm cavity is not large enough to accept the FastConnect plug at all (see *Figure 3* for dimensions), complete the following instructions to disassemble, install, and reassemble the torch.

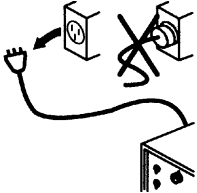
		<p>WARNING! ELECTRIC SHOCK CAN KILL</p>
		<p>Disconnect electrical power before performing any maintenance.</p> <p>The maintenance procedures in this section must be performed by a qualified technician.</p> <p>See the <i>Safety and Compliance Manual (80669C)</i> for more safety precautions.</p>

 The instructions to disassemble and reassemble all 3 models of robotic torches are the same. The 45° robotic torch is shown in the figures that follow.

Figure 4 – Duramax 45°



- | | | | |
|---|--------------------------------------|----|-------------------------------------|
| 1 | Right half of the positioning barrel | 7 | Gas fitting flange |
| 2 | Cap-sensor switch connector | 8 | Positioning barrel screws (6) |
| 3 | Cap-sensor switch | 9 | Left half of the positioning barrel |
| 4 | Pilot terminal screw | 10 | Torch lead |
| 5 | Torch body (torch head and gas tube) | 11 | Strain relief |
| 6 | Gas supply tube fitting | | |

Figure 5 – Duramax Hyamp 45°

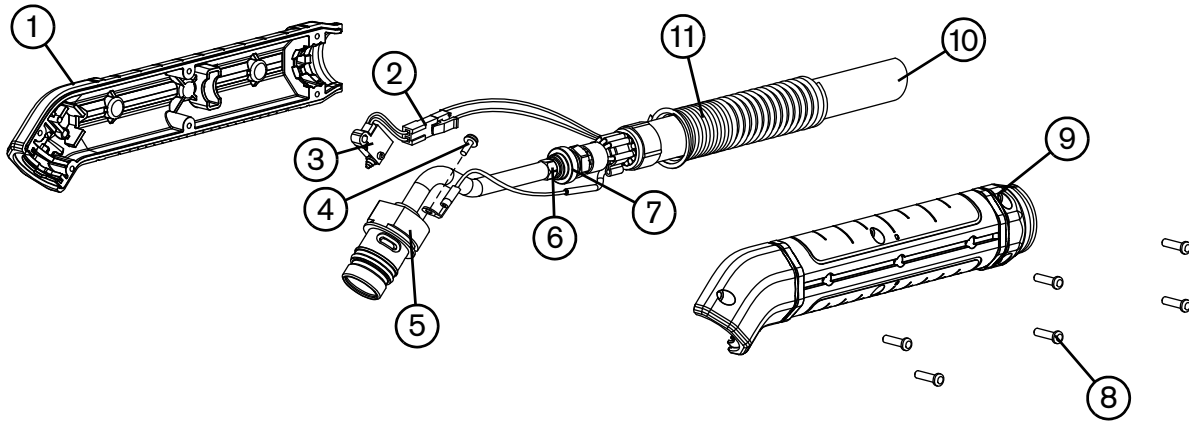
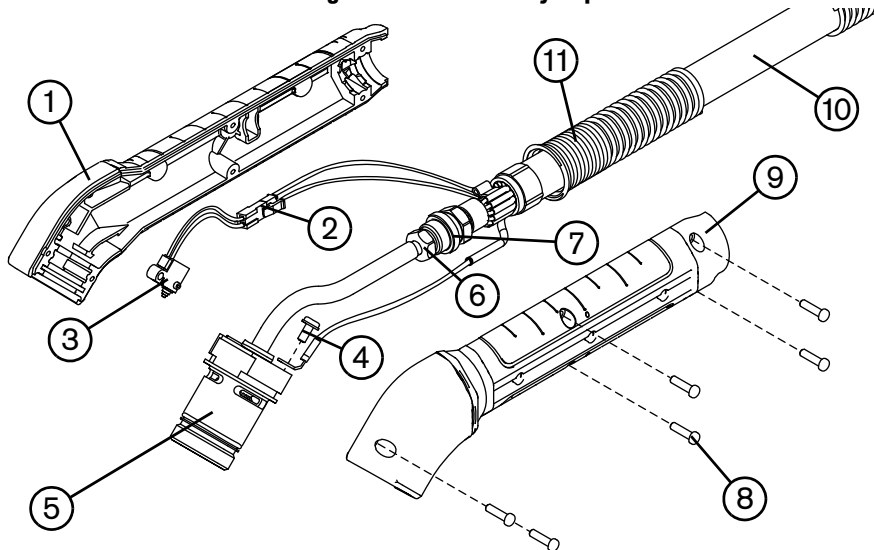

- | | | | |
|---|--------------------------------------|----|-------------------------------------|
| 1 | Right half of the positioning barrel | 7 | Gas fitting flange |
| 2 | Cap-sensor switch connector | 8 | Positioning barrel screws (6) |
| 3 | Cap-sensor switch | 9 | Left half of the positioning barrel |
| 4 | Pilot terminal screw | 10 | Torch lead |
| 5 | Torch body (torch head and gas tube) | 11 | Strain relief |
| 6 | Gas supply tube fitting | | |

1. Disconnect the torch lead from the power supply.

 While disconnecting and reconnecting the torch parts, maintain the same orientation between the torch body and torch lead. Twisting the torch body in relation to the torch lead can cause damage.

2. Remove the consumables.

3. Place the torch on a flat surface with the left half of the positioning barrel facing up.

 The left half of the positioning barrel is the side with the screws.

 It may be helpful to clamp the lead in place to keep it from moving.

4. Remove the screws from the left half of the positioning barrel.

5. Lift the left half of the positioning barrel away from the torch.

6. The torch body fits snugly into the right half of the positioning barrel. While holding the torch body, gently press the right half of the positioning barrel away from the torch body to remove it.

7. Slide the cap-sensor switch off its mounting post.

Figure 6 – Duramax 45° (top) and Duramax Hyamp 45° (bottom)

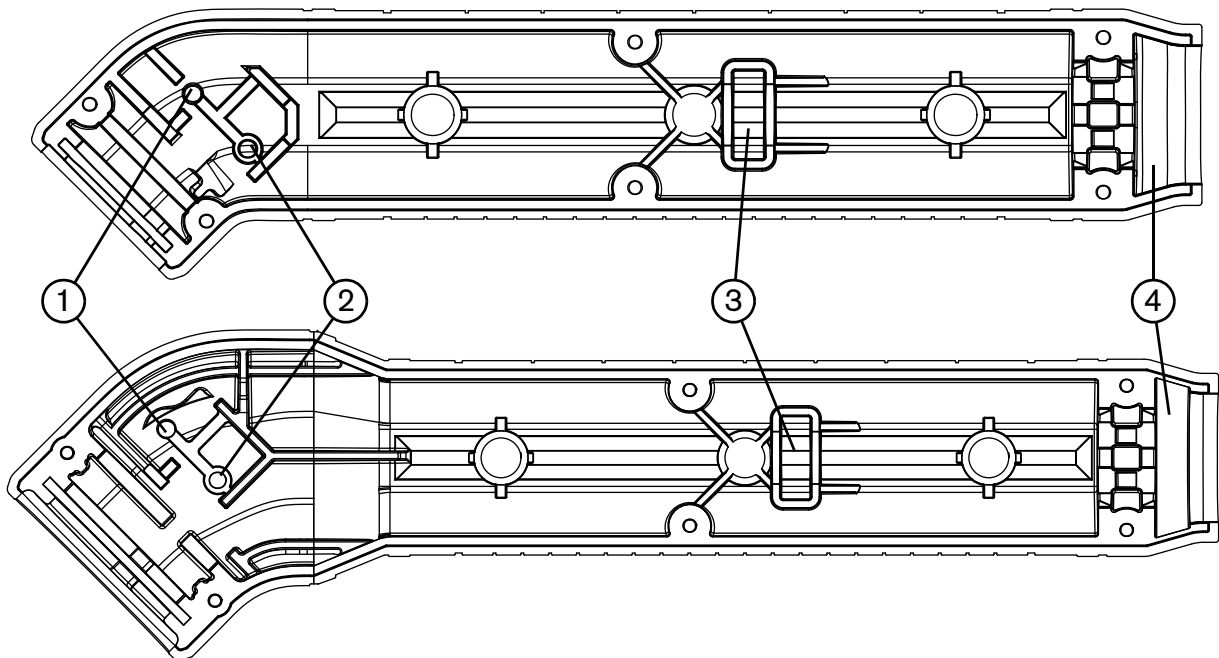

1 Cap-sensor switch mounting post

2 Cap-sensor switch post hole

3 Gas fitting flange slot

4 Strain relief slot

8. Remove the pilot terminal screw.

2 – Torch Setup

9. Use 2 wrenches to loosen the gas fitting that secures the torch body to the torch lead.



Heating the gas fitting can help loosen the threadlocker and make removing the torch body easier. Slowly heat only the fitting with a heat gun until you can easily loosen the fitting.



CAUTION!

Do not apply heat to the wires. Heating the wires could cause damage to the connections in the torch lead.



CAUTION!

Always use 2 wrenches to properly loosen and tighten the hex nuts and bolts mentioned in these procedures. A strong threadlocker is used to assemble the torch, and loosening the nuts incorrectly can damage the threads.

10. Cover the end of the gas line on the torch lead with tape to keep dirt and other contaminants from getting in the gas line.
11. Route the torch lead through the robot's through-arm cavity.
12. Being careful not to get any threadlocker on the conical surface of the gas tube fitting, apply a drop of threadlocker, included in the kit, to the threads of the gas tube fitting on the torch body.



The drop should not be wider than 2 threads in diameter.



CAUTION!

Do not get any threadlocker on the conical surface of the gas tube fitting to avoid causing damage to the torch. If any threadlocker does get on this surface, clean it off immediately.

Figure 7

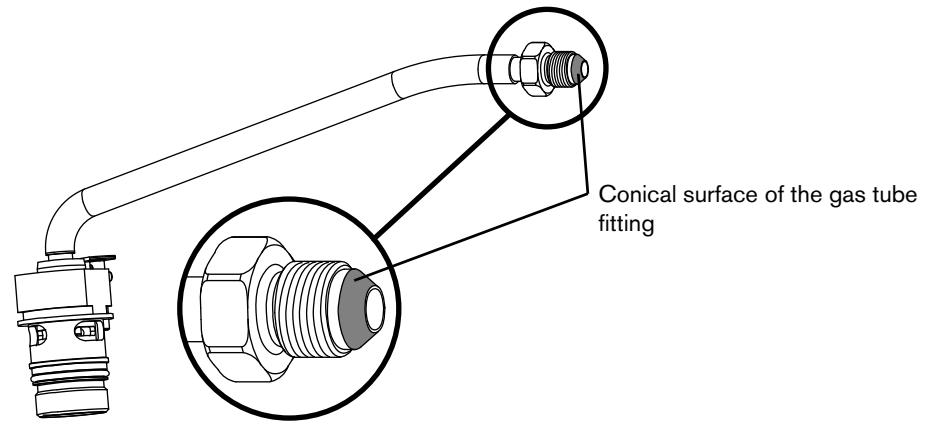

13. Thread the torch body into the torch lead until snug.

 The white wires of the lead should be facing up.

14. Use 2 wrenches to tighten the gas fitting that secures the torch body to the torch lead to 69.1 kg-cm (60 inch-pounds).

15. Route the pilot arc wire under the gas tube and above the slot for the gas hose fitting's flange. See *Figure 8* and *Figure 9*.

16. Tighten the pilot terminal screw to 17.3 kg-cm (15 inch-pounds).

 The wire should go slightly down into the positioning barrel.

17. Press the cap-sensor switch into its post hole and onto its mounting post. (See *Figure 6*.)

18. Route the cap-sensor wires below the slot for the gas hose fitting's flange.

Figure 8 – Duramax wire routing

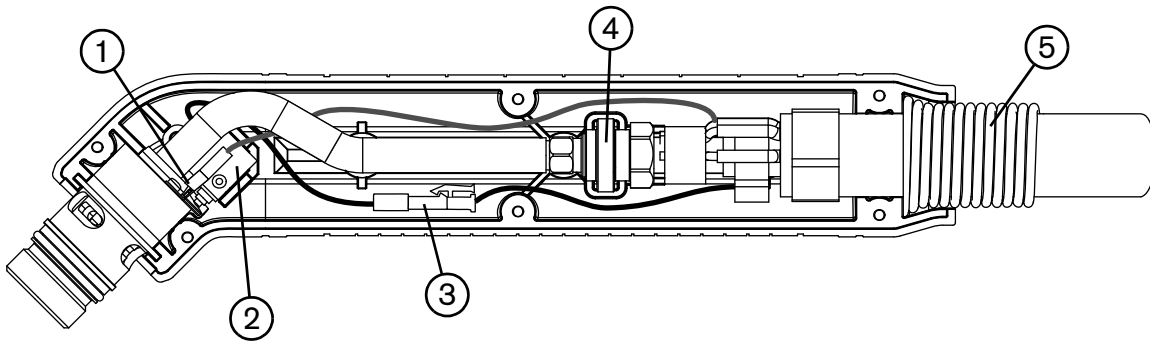

- | | |
|-------------------------------|----------------------|
| 1 Pilot arc wire terminal | 4 Gas fitting flange |
| 2 Cap-sensor switch | 5 Strain relief |
| 3 Cap-sensor switch connector | |

Figure 9 – Duramax Hyamp wire routing

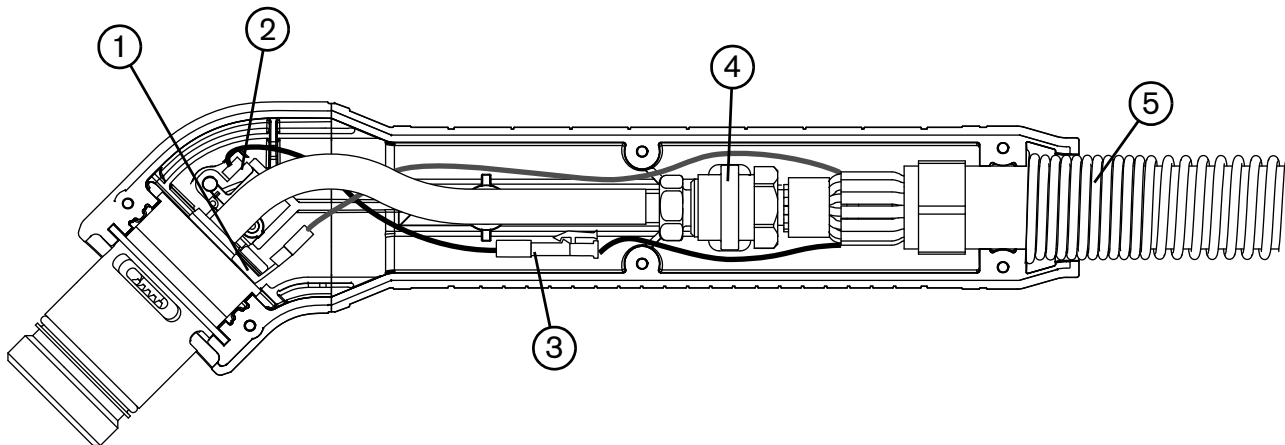

- | | |
|-------------------------------|----------------------|
| 1 Pilot arc wire terminal | 4 Gas fitting flange |
| 2 Cap-sensor switch | 5 Strain relief |
| 3 Cap-sensor switch connector | |

19. Press the torch body into the right half of the positioning barrel with the gas fitting flange aligned with the slot in the positioning barrel.
20. Align the strain relief with the strain relief slot in the positioning barrel.
21. Being careful that the positioning barrel and gas fitting flange do not pinch the wires, align the left half of the positioning barrel with the right half.
22. Install the screws in the left half of the positioning barrel. Tighten to 15.0 kg-cm (13.0 inch-pounds).

23. If the O-ring on the torch body is dry, lubricate it and the threads with a thin layer of silicone lubricant.



Silicone lubricant is included in several of the replacement kits.

24. Install the consumables.

25. Reconnect the torch and gas supply, and turn ON (I) the power.

Mount the torch

Each style of robotic torch has 2 different mounting methods to maintain consistent positioning:

1. Increment markings – These are located on each side of the positioning barrel. One set is in inches and the other set is in centimeters.
2. Positioning holes – These are equally spaced along the anti-rotational slots on each side of the barrel.

Figure 10

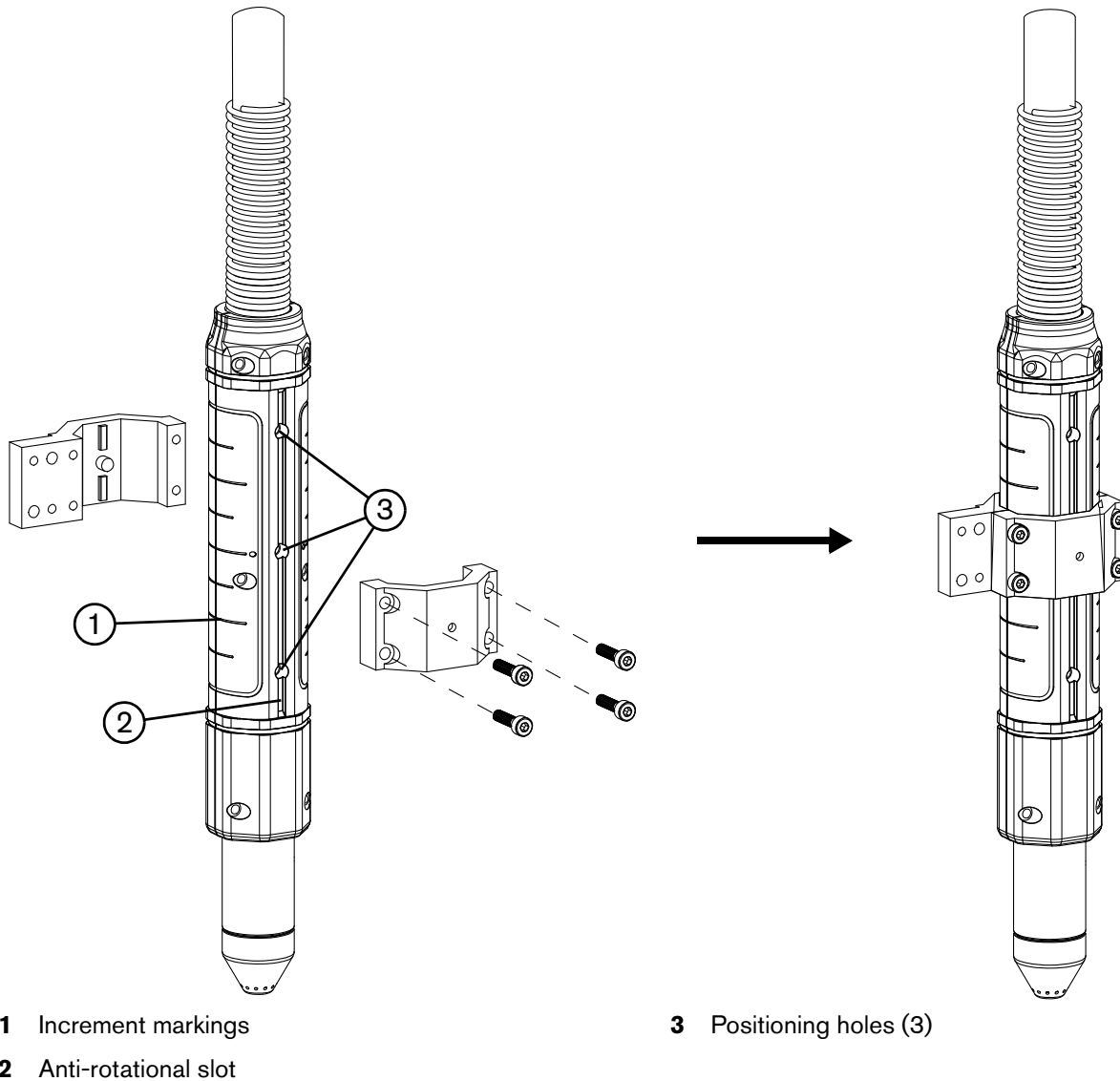

The robotic torch must be correctly mounted to the robot's arm to make sure that there is proper torch-to-work distance throughout each cut. A robotic torch clamp with mating positioning dowels and anti-rotational tabs is available from Hypertherm. If you choose to use an alternate torch clamp, follow the manufacturer's instructions on how to mount the torch in the clamp. It is the customer's responsibility to interface between the torch clamp and the robot's arm.

For the recommended minimum bend radius of the torch lead, see *Figure 1* or *Figure 2* on page 16.

If you are using Hypertherm's robotic torch clamp (228806), complete the following instructions:

1. Mount the robotic torch clamp using one set of mounting holes (through hole or threaded).

Figure 11

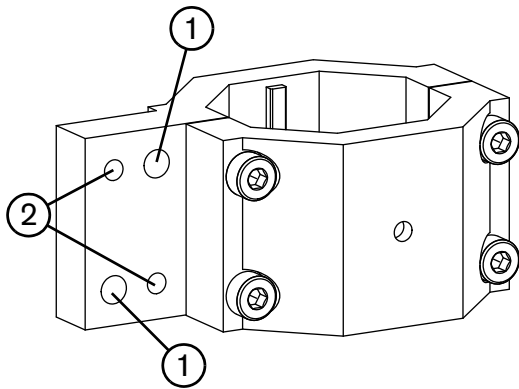

1 0.45 cm (0.18 inch) through hole

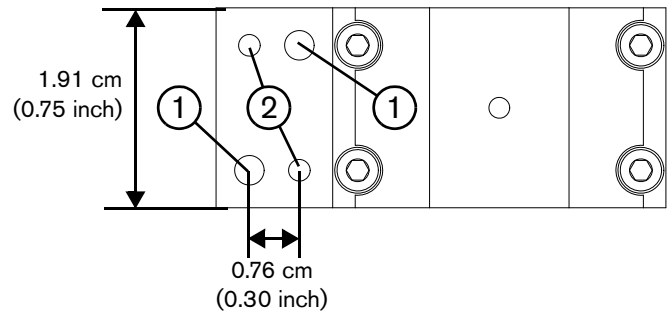

2 M4 x 0.7 threaded hole

2. Separate the torch clamp by removing the 4 screws from the front half of the torch clamp.

 A second positioning dowel is provided in the kit to be used for additional mounting support, if necessary, or as a replacement part.

Figure 12



1 Positioning dowel

2 Rear half of the clamp

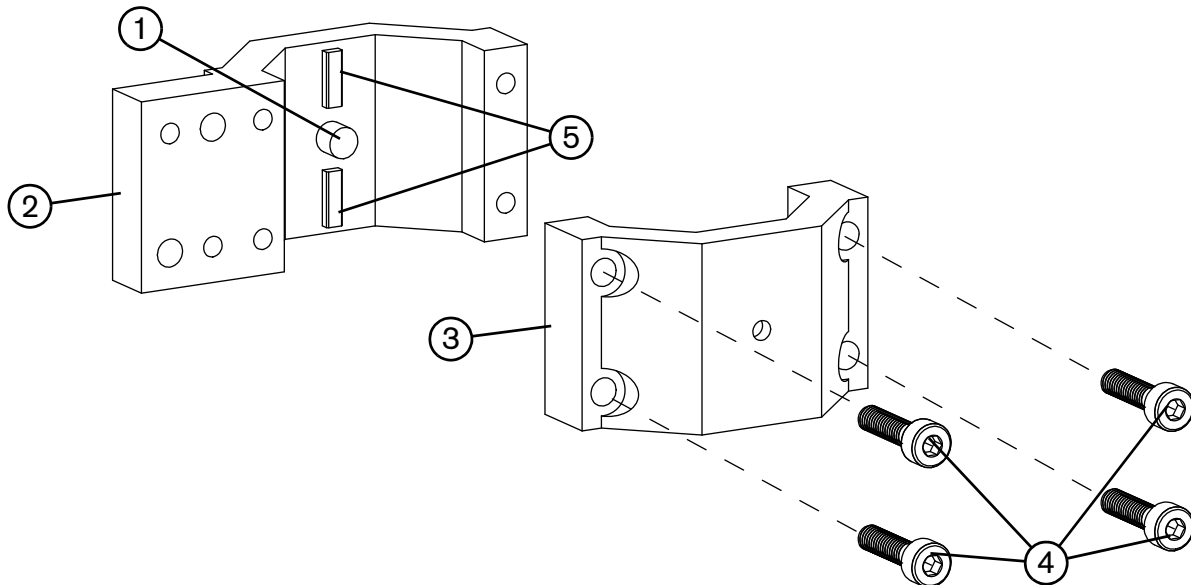
3 Front half of the clamp

4 Screws (4)

5 Anti-rotational tabs

2 – Torch Setup

- Align the torch with the clamp using either the increment markings or the positioning holes.



If you are using the increment markings, you must remove the positioning dowel from the rear half of the torch clamp. Remove the dowel by pressing the end located in the center hole of the torch clamp until it comes out.

- Verify that the anti-rotational tabs on each half of the torch clamp are aligned with the slots in the torch.
- Loosely hand tighten the 4 screws.
- Starting with the upper left screw, step torque the 4 screws to 17.3 kg·cm (15 inch·pounds) in the pattern shown below ① – ④.

Figure 13

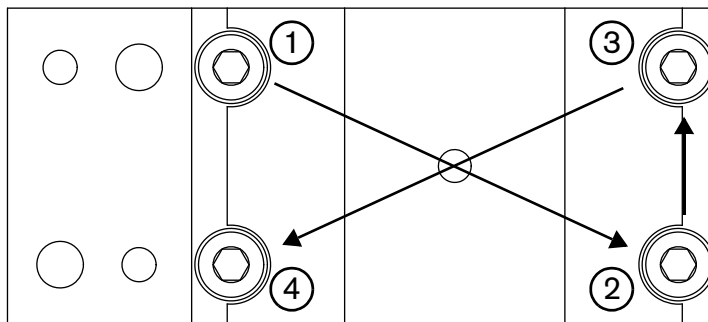

Consumable life

How often you need to change the consumables on your torch will depend on a number of factors:

- The thickness of the metal being cut.
- The average length of cut.
- The air quality (presence of oil, moisture, or other contaminants).
- Whether you are piercing the metal or starting cuts from the edge.
- Proper torch-to-work distance when gouging or cutting with unshielded consumables.
- Proper pierce height.
- Whether you are cutting in “continuous pilot arc” mode or normal mode. Cutting with a continuous pilot arc causes more consumable wear.

You will find more information about proper cutting techniques in *Operation* on page 47.

Choosing the consumables

Duramax robotic torches

Duramax robotic torches are shipped with a consumable kit that includes enough consumables to create a complete consumable set for 65, 85, or 105 amperage shielded cutting. An ohmic-sensing retaining cap is available for use with shielded consumables, a deflector is available for unshielded cutting and FineCut® consumables are available for fine-featured cutting on thin materials. All 3 styles of Duramax robotic torches use the same consumables.

More consumables are available for this torch, but can require testing to find the optimal settings. You can find information about consumables at www.hypertherm.com.

With unshielded consumables, you must keep the torch a small distance, about 2.0 mm (0.08 inch), away from the workpiece. Unshielded consumables generally have a shorter life than shielded consumables.

Duramax consumables

Duramax mechanized shielded higher amperages*

- Maximum amperage: 105 A
- For use with Powermax105 plasma power supplies

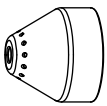

220993
Shield

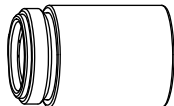

220854
Retaining cap



220990
Nozzle

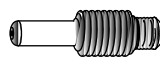

220842
Electrode

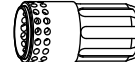

220994
Swirl ring

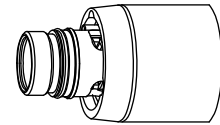

Duramax mechanized shielded lower amperages*

- Maximum amperage: 85 A
- For use with Powermax45, Powermax45 XP, Powermax65, Powermax85, and Powermax105 plasma power supplies

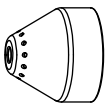

220817
Shield

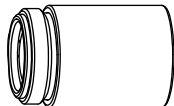

220854
Retaining cap



220941
Nozzle (45 A)



220819
Nozzle (65 A)



220816
Nozzle (85 A)

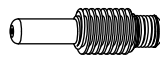

220842
Electrode

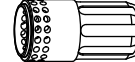

220857
Swirl ring

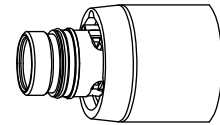

Duramax FineCut shielded*

- Maximum amperage: 45 A
- For use with Powermax45, Powermax45 XP, Powermax65, Powermax85, and Powermax105 plasma power supplies

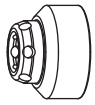

220948
Shield

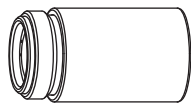

220854
Retaining cap



220930
Nozzle

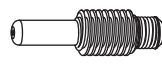

220842
Electrode

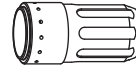

220947
Swirl ring

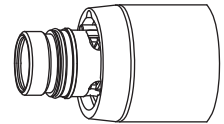

***Ohmic-sensing retaining cap**

You can use the ohmic-sensing retaining cap (220953) with the above consumable sets instead of the standard retaining cap (220854).

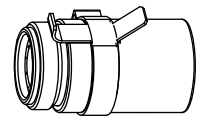

Duramax mechanized unshielded higher amperages

- Maximum amperage: 105 A
- For use with Powermax105 plasma power supplies



220955
Deflector

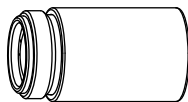

220854
Retaining cap



220990
Nozzle

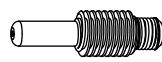

220842
Electrode

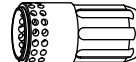

220994
Swirl ring

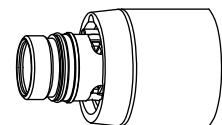

2 – Torch Setup

Duramax mechanized unshielded lower amperages

- Maximum amperage: 85 A
- For use with Powermax45, Powermax45 XP, Powermax65, and Powermax85 plasma power supplies

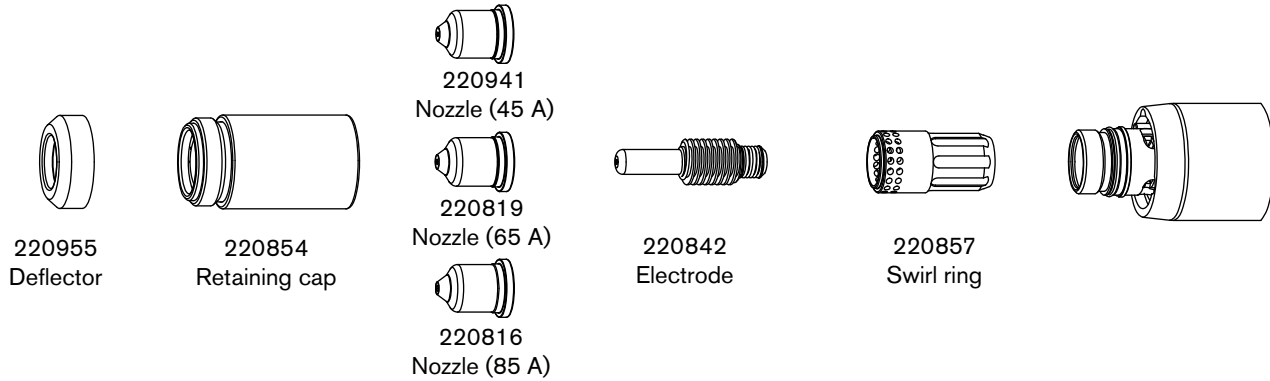

Duramax FineCut unshielded

- Maximum amperage: 45 A
- For use with Powermax45, Powermax45 XP, Powermax65, Powermax85, and Powermax105 plasma power supplies

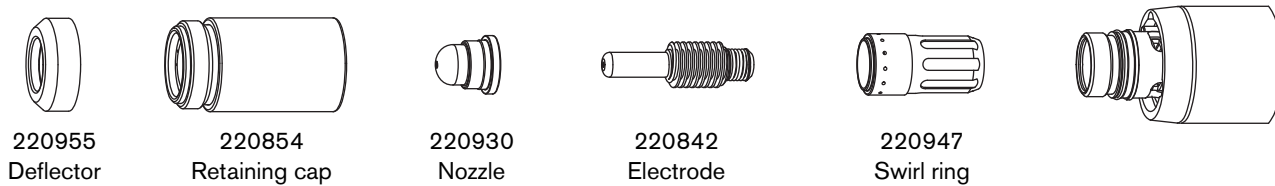

Duramax Hyamp robotic torches

Duramax Hyamp robotic torches ship with a consumable kit that includes enough consumables to create a complete consumable set for 45, 65, 105, or 125 amperage shielded cutting. Also notice that specific consumables are not available for cutting at 85 A. Use the standard (drag-cutting) 105/125 A consumables to cut at 85 A. An ohmic-sensing retaining cap is available for use with shielded consumables, and FineCut® consumables are available for fine-featured cutting on thin materials. All 3 styles of Duramax Hyamp robotic torches use the same consumables.

More consumables are available for this torch, but can require testing to find the optimal settings. You can find information about consumables at www.hypertherm.com.

Duramax Hyamp consumables

Duramax Hyamp mechanized shielded higher amperages*

Maximum amperage: 125 A

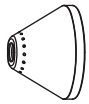

220976
Shield

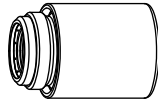

220977
Retaining cap



220975
Nozzle

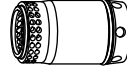

220997
Swirl ring

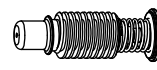

220971
Electrode

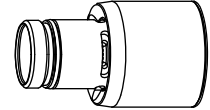

Duramax Hyamp mechanized shielded lower amperages *

Maximum amperage: 65 A

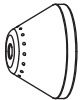

420168
Shield

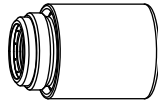

220977
Retaining cap



420158 (45 A)
420169 (65 A)
Nozzle

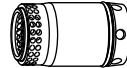

220997
Swirl ring

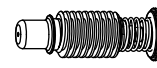

220971
Electrode

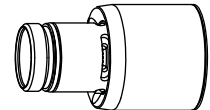

Duramax Hyamp FineCut shielded*

Maximum amperage: 45 A



420152
Shield

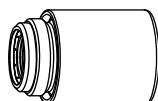

220977
Retaining cap



420151
Nozzle

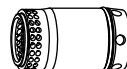

220997
Swirl ring

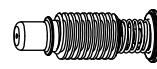

220971
Electrode

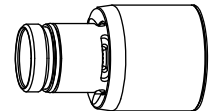

*Ohmic-sensing retaining cap

You can use the ohmic-sensing retaining cap (420156) with the above consumable sets instead of the standard retaining cap (220977).



Installing the consumables

		<p>WARNING!</p> <p>INSTANT-ON TORCHES</p> <p>PLASMA ARC CAN CAUSE INJURY AND BURNS</p>
	<p>The plasma arc comes on immediately when the torch trigger is activated. Make sure the power is OFF before changing the consumables.</p>	

To operate the robotic torch, a complete set of consumable parts must be installed: shield, retaining cap, nozzle, electrode, and swirl ring.

If the O-ring on the torch body is dry, lubricate it and the threads with a thin layer of silicone lubricant. Silicone lubricant is included in several of the replacement kits. Then, to operate the torch, install the consumables as shown in *Figure 14*. Make sure to use the appropriate parts to the corresponding system amperage. To replace the consumables, turn the power switch to the OFF (O) position, remove the consumables, and install the new consumables by referring to *Figure 14*.

Figure 14

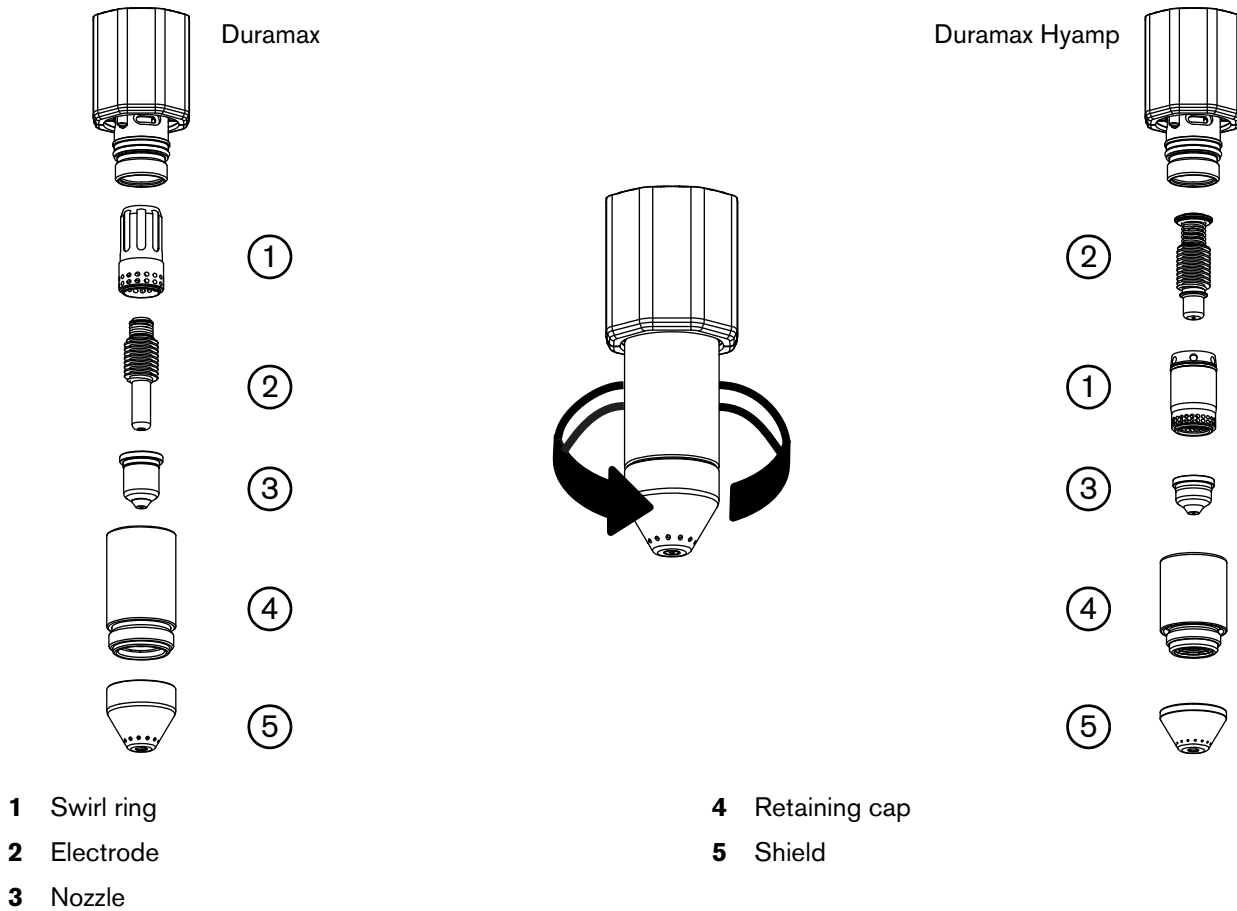

Connecting the torch lead

The Powermax45, Powermax45 XP, Powermax65, Powermax85, Powermax105, and Powermax125 have FastConnect, a quick-disconnect system for connecting and disconnecting hand, machine, and robotic torch leads. When connecting or disconnecting a torch, first turn OFF the system. To connect the torch, push the connector into the receptacle on the front of the power supply.

Figure 15

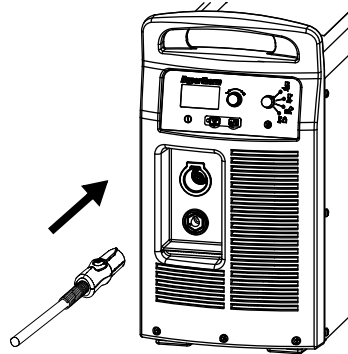

To remove the torch, press the red button on the connector and pull the connector out of the receptacle.

Figure 16

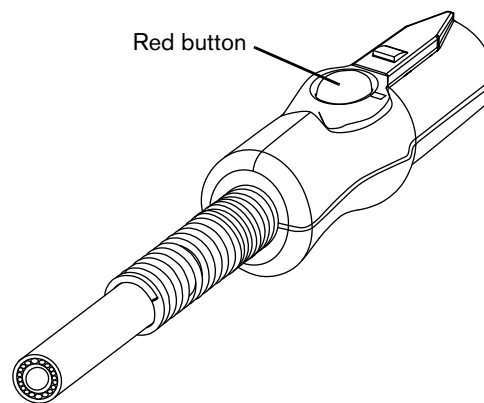

Connecting a remote-start pendant

An optional remote-start pendant is available for use with Powermax systems.

- Part number 128650: 7.6 m (25 feet)
- Part number 128651: 15 m (50 feet)
- Part number 128652: 23 m (75 feet)
- Part number 428755: 45 m (150 feet)

If your power supply has the machine interface receptacle on the rear of the power supply, remove the receptacle cover and plug the Hypertherm remote-start pendant into the receptacle. If the system does not have a receptacle installed, a CPC port upgrade kit (428653 for Powermax45 XP) (228697 for Powermax65/85) (228884 for Powermax105/125) is available from Hypertherm.



The remote-start pendant is for use only with a robotic or machine torch. It will not operate if a hand torch is installed.

Figure 17

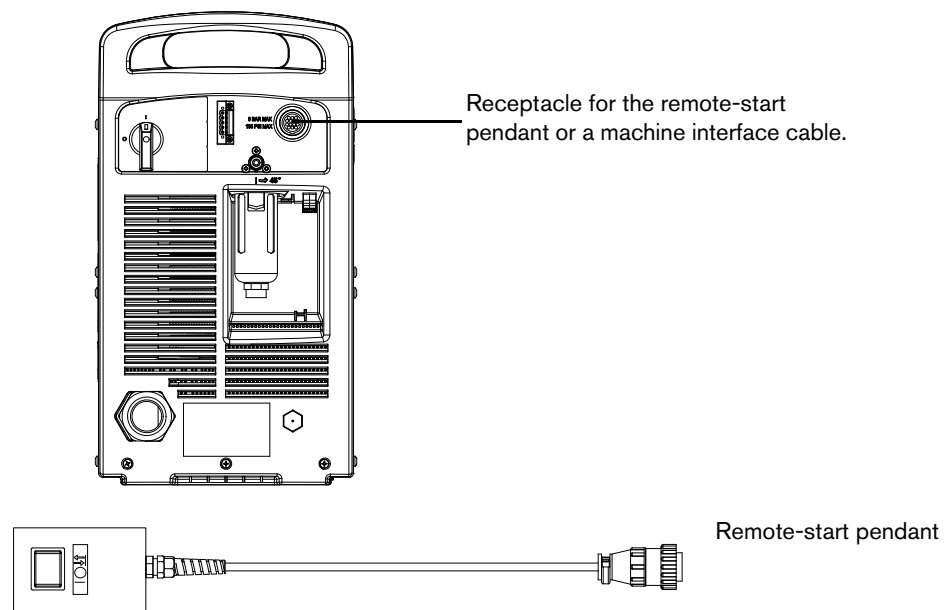

Connecting the machine interface cable

The power supply may be equipped with a five-position voltage divider board. The built-in voltage divider provides a scaled down arc voltage of 20:1, 21.1:1, 30:1, 40:1, or 50:1. The maximum output voltage varies by system. See *Table 1* on page 44 . A receptacle on the rear of the power supply (see *Figure 17*) provides access to the scaled down arc voltage and signals for arc transfer and plasma start.

 The factory presets the voltage divider to 50:1. To change the voltage divider to a different setting, see *Setting the five-position voltage divider* on page 45.



CAUTION!

The factory-installed internal voltage divider provides a system-specific maximum voltage under open circuit conditions. See *Table 1* on page 44 for maximum voltages. This is an impedance-protected functional extra low voltage (ELV) output to prevent shock, energy, and fire under normal conditions at the machine interface receptacle and under single fault conditions with the machine interface wiring. The voltage divider is not fault tolerant, and ELV outputs do not comply with safety extra low voltage (SELV) requirements for direct connection to computer products.

Hypertherm offers several choices of machine interface cables:

- To use the built-in voltage divider that provides a scaled down arc voltage in addition to signals for arc transfer and plasma start:
 - Use part number 228350 (7.6 m, 25 feet) or 228351 (15 m, 50 feet) for wires terminated with spade connectors.
 - Use one of the following part numbers for a cable terminated with a D-sub connector. (Compatible with Hypertherm products, such as EDGE® Pro Ti and Sensor™ PHC.)
 - 223354 (3.0 m, 10 feet)
 - 223355 (6.1 m, 20 feet)
 - 223048 (7.6 m, 25 feet)
 - 223356 (10.7 m, 35 feet)
 - 123896 (15 m, 50 feet)
- To use signals for arc transfer and plasma start only, use either part number 023206 (7.6 m, 25 feet) or part number 023279 (15 m, 50 feet). These cables have spade connectors as follows:

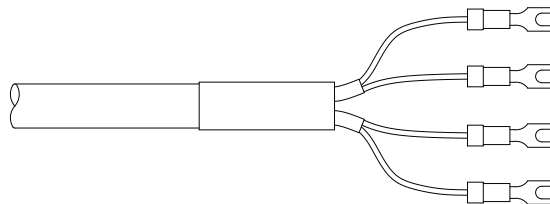

2 – Torch Setup

Refer to *Machine interface pinout* on page 43 for receptacle pinout information.



The cover on the machine interface receptacle prevents dust and moisture from damaging the receptacle when not in use. This cover (127204) should be replaced if damaged or lost.

Refer to *Maintenance and Parts* on page 65 for more information.

Installation of the machine interface cable must be performed by a qualified service technician. To install a machine interface cable:

1. Turn OFF the power and disconnect the power cord.
2. Remove the machine interface receptacle's cover from the rear of the power supply.
3. Connect the Hypertherm machine interface cable to the power supply.
4. If you are using a cable with a D-sub connector on the other end, plug it into the appropriate pin connector on the torch height controller or CNC. Secure it with the screws on the D-sub connector.

If you are using a cable with wires and spade connectors on the other end, terminate the machine interface cable inside the electrical enclosure of the torch height controller or CNC controller to prevent unauthorized access to the connections after installation. Verify that the connections are correct and that all live parts are enclosed and protected before operating the equipment.



The integration of Hypertherm equipment and customer-supplied equipment including interconnecting cords and cables, if not listed and certified as a system, is subject to inspection by local authorities at the final installation site.

The connector sockets for each type of signal available through the machine interface cable are shown in *Figure 18*. *Table 1* on page 44 provides details about each signal type.

Machine interface pinout

Figure 18 – Connector sockets

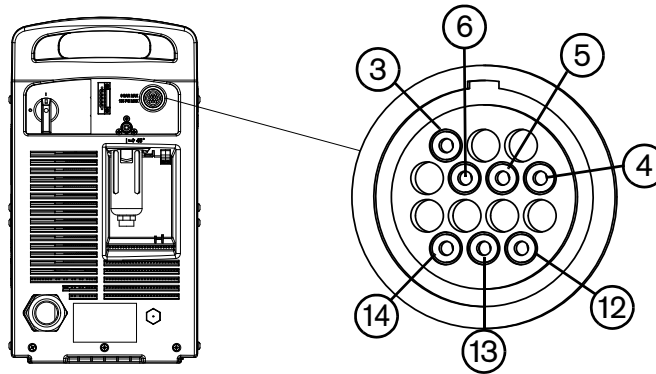

Refer to *Table 1* when connecting the power supply to a torch height controller or CNC controller with a machine interface cable.

2 – Torch Setup

Table 1 – Machine interface cable signals

Signal	Type	Notes	Connector sockets	External cable wires	Internal cable wires
Start (start plasma)	Input	Normally open. 18 VDC open circuit voltage at START terminals. Requires dry contact closure to activate.	3	Green	Black
			4	Black	Red
Transfer (start machine motion)	Output	Normally open. Dry contact closure when the arc transfers. 120 VAC/1 A maximum at the machine interface relay.	12	Red	White
			14	Black	Green
Voltage divider	Output	Divided arc signal of 20:1, 21.1:1, 30:1, 40:1, 50:1. The maximum output voltage varies by system: <ul style="list-style-type: none"> ▪ Powermax45: 7 V ▪ Powermax45 XP/125: 16 V ▪ Powermax65/85: 18 V ▪ Powermax105: 15 V 	5 (-)	Black (-)	Black (-)
			6 (+)	White (+)	Red (+)
Ground	Ground		13		Green/yellow

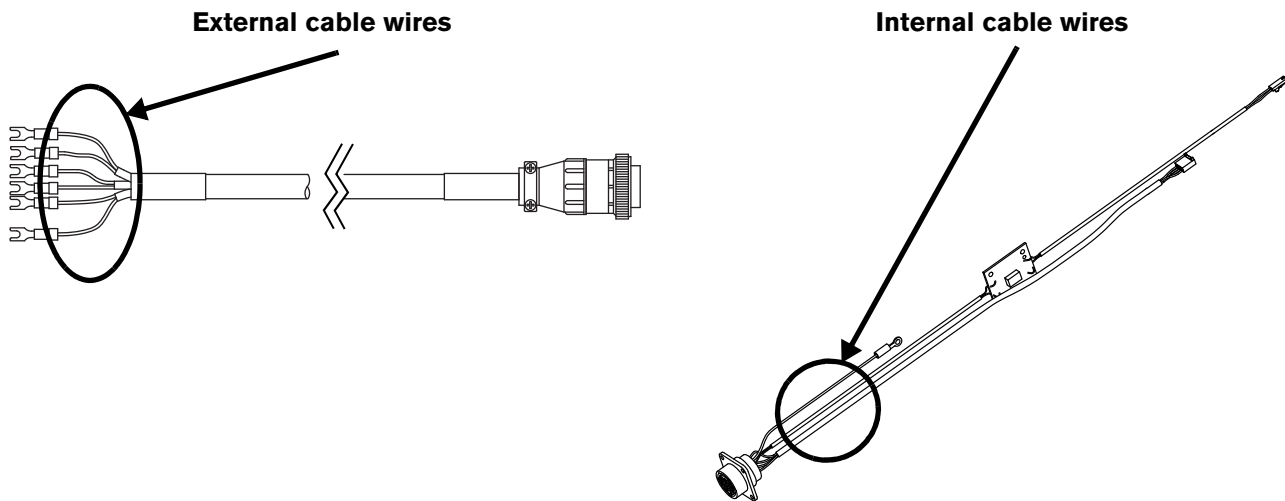

Setting the five-position voltage divider

To change the factory preset voltage divider from 50:1 to a different setting:

1. Turn OFF the power supply and disconnect the power cord.
2. Remove the power supply cover.
3. Locate the voltage divider DIP switches on the left side of the power supply.

 Figure 19 shows the default setting (50:1) with the number 4 switch up.

Figure 19 – Voltage divider at default setting (50:1)



4. Set the DIP switches to one of the following settings, and replace the power supply cover.

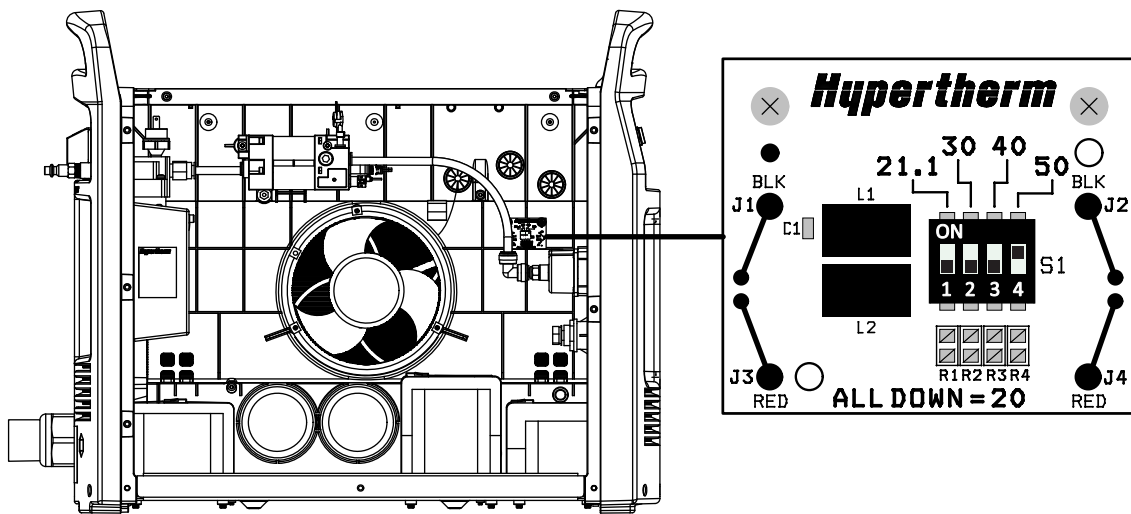
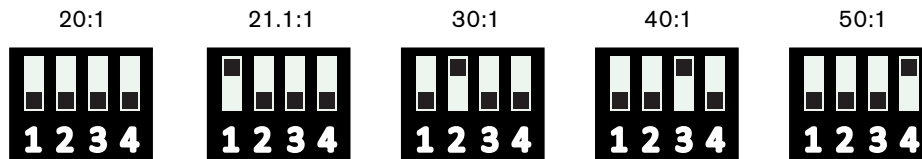

If the Hypertherm five-position voltage divider does not supply the required voltage for your application, contact your system integrator for assistance.

Using the cut charts

The cut charts for each set of mechanized consumables can be found in the Operator Manual that shipped with the system. The manuals also can be downloaded from Hypertherm's website (www.hypertherm.com) using the "Documents library" link. A consumable diagram with part numbers precedes each set of charts. For each consumable type, there are Metric and English charts for mild steel, stainless steel, and aluminum.

Each chart contains the following information:

- **Material Thickness** – Thickness of the workpiece (metal plate being cut).
- **Torch-to-Work Distance** – For shielded consumables, the distance between the shield and the workpiece during cutting. For unshielded consumables, the distance between the nozzle and the workpiece during cutting.
- **Initial Pierce Height** – Distance between the shield (shielded) or the nozzle (unshielded) and the workpiece when the torch is triggered, prior to descending to the cut height.
- **Pierce Delay Time** – Length of time the triggered torch remains stationary at the pierce height before the torch starts the cutting motion.
- **Best Quality Settings** (cut speed and voltage) – Settings that provide the starting point for finding the best cut quality (best angle, least dross, best cut-surface finish). Adjust the speed for your application and table to obtain the desired result.
- **Production Settings** (cut speed and voltage) – 70% to 80% of the maximum speed ratings. These speeds result in the greatest number of cut parts, but not necessarily the best possible cut quality.



The arc voltage increases as the consumables wear, so the voltage setting may need to be increased to maintain the correct torch-to-work distance. Some CNCs monitor the arc voltage and adjust the torch lifter automatically.

Each cut chart lists hot and cold air flow rates.

- **Hot air flow rate** – Plasma is on, the system is operating at running current, and the system is in a steady state at the default system pressure (automatic mode).
- **Cold air flow rate** – Plasma is off and the system is in a steady state with air flowing through the torch at the default system pressure.



Hypertherm collected the cut chart data under laboratory test conditions using new consumables.

Using the robotic torch

Since the robotic torch, combined with a Powermax system, can be used in a wide variety of applications, you will need to refer to the robot manufacturer's instructions for specifics on operating the robotic torch in your configuration. However, the information in the following section will help you optimize cut quality and maximize consumable life.

Using the robotic teach tool

A robotic torch teach tool is available from Hypertherm to assist with programming the robot before cutting. This teach tool is available for both Duramax (229456) and Duramax Hyamp (229832) robotic torches.

The torch teach tool enables the system operator to program the robot's cutting path, while visually verifying the torch will not touch the workpiece while cutting. Contact with the workpiece while cutting can damage the shield and nozzle and affect the cut surface. The torch teach tool is equipped with a spring-loaded tip to allow for variations in consumable lengths and stand-off distances.

To install the torch teach tool:

1. Turn OFF (●) the power.
2. Remove the consumables from the torch.
3. Thread the torch teach tool onto the end of the torch in place of the consumables.

As a safety feature, the torch teach tool does not engage the cap-sensor switch. This will cause a cap-sensor fault code to be generated when the system is turned ON, thereby disabling the torch from firing while in teach mode.

After programming the robot:

1. Turn OFF (●) the power.
2. Remove the torch teach tool.
3. Install the consumables.

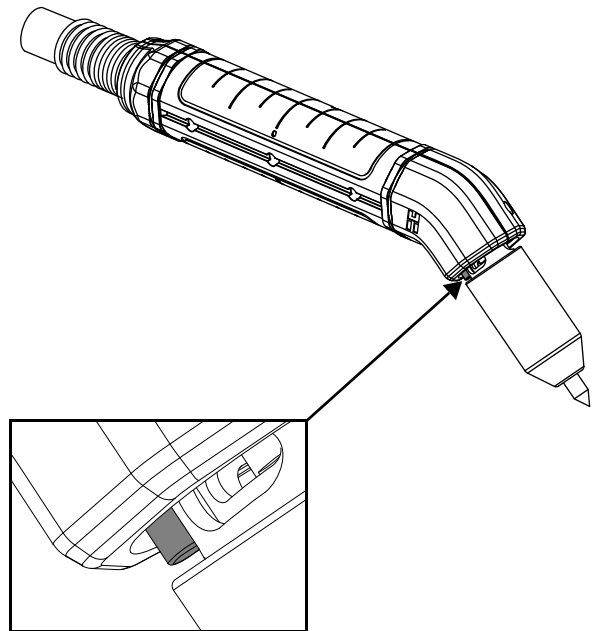

Understand and optimize cut quality

Several factors affect cut quality:

- Cut angle – The degree of angularity of the cut edge.
- Dross – The molten material that solidifies on the top or bottom of the workpiece.
- Straightness of the cut surface – The cut surface can be concave or convex.

The following topics explain how these factors can affect cut quality.

Cut or bevel angle

- A positive cut angle results when more material is removed from the top of the cut than from the bottom.
- A negative cut angle results when more material is removed from the bottom of the cut.

Figure 20 – Cut angles

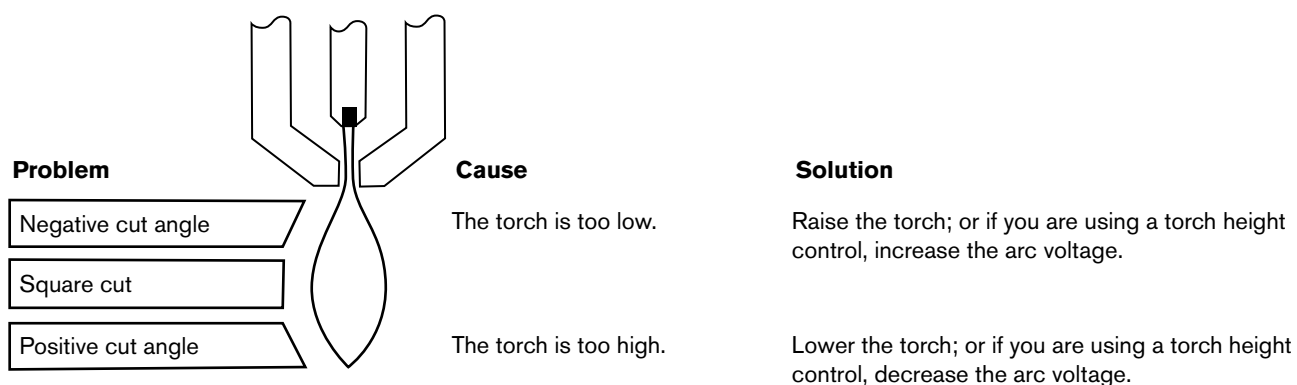

 The squarest cut angle will be on the *right* side with respect to the forward motion of the torch. The left side will always have some degree of cut angle.

To determine whether a cut-angle problem is being caused by the plasma system or the drive system, make a test cut and measure the angle of each side. Next, turn the torch 90° in its holder and repeat the process. If the angles are the same in both tests, the problem is in the drive system.

If a cut-angle problem persists after mechanical causes have been eliminated, check the torch-to-work distance, especially if the cut angles are all positive or all negative. Also consider the material being cut: if the metal is magnetized or hardened, you are more likely to experience cut angle problems.

Dross

Some amount of dross will always be present when cutting with air plasma. However, you can minimize the amount and type of dross by adjusting your system correctly for your application.

Excess dross appears on the top edge of both pieces of the plate when the torch is too low (or voltage is too low when using a torch height control). Adjust the torch or adjust the voltage in small increments (5 volts or less) until the dross is reduced.



3 – Operation

Low-speed dross forms when the torch's cutting speed is too slow and the arc angles ahead. It forms as a heavy, bubbly deposit at the bottom of the cut and can be removed easily. Increase the speed to reduce this type of dross.

High-speed dross forms when the cutting speed is too fast and the arc angles behind. It forms as a thin, linear bead of solid metal attached very close to the cut. It is more firmly attached to the bottom of the cut than at low speed and is difficult to remove. To reduce high-speed dross:

- Decrease the cutting speed.
- Decrease the torch-to-work distance.

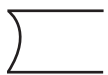
Straightness of the cut surface

-  A typical plasma cut surface is slightly concave. The cut surface may become more concave, or convex. Correct torch height is required to keep the cut surface acceptably close to straight. Worn consumables also affect the straightness of the cut.
-  A strongly concave cut surface occurs when the torch-to-work distance is too low. Increase the torch-to-work distance to straighten the cut surface.
-  A convex cut surface occurs when the torch-to-work distance is too great or the cutting current is too high. First, try lowering the torch, then reduce the cutting current.

Piercing a workpiece using the robotic torch

As with the hand torch and machine torch, you can start a cut with the robotic torch at the edge of the workpiece or by piercing the workpiece. Piercing may result in a shorter consumable life than with edge starts.

The cut charts, provided in the system's Operator Manual, include a column for the recommended torch height when starting a pierce. For the Powermax45, Powermax65, Powermax85, and Powermax105, the pierce height is generally 2.5 times the cutting height. For the Powermax45 XP and Powermax125, the pierce height is generally between 1.5 and 4 times the cut height. Refer to the cut charts for specific values.

The pierce delay must be long enough that the arc can pierce the material before the torch moves, but not so long that the arc "wanders" while trying to find the edge of a large hole. As consumables wear, this delay time may need to be increased. Pierce delay times given in the cut charts are based on average delay times throughout the life of the consumables.

When piercing materials close to the maximum thickness for a specific process, consider the following important factors:

- Allow a lead-in distance approximately equal to the thickness of the material being pierced. For example, 20 mm (0.75 inch) material requires a 20 mm lead-in.
- To avoid damage to the shield from the buildup of molten material created by the pierce, do not allow the torch to descend to cut height until it has cleared the puddle of molten material.
- Different material chemistries can have an adverse effect on the pierce capability of the system. In particular, high-strength steel with a high manganese or silicon content can reduce the maximum pierce capability. Hypertherm calculates mild steel parameters with certified A-36 plate.
- Using a "flying pierce" (that is, starting torch motion immediately after transfer and during the pierce process) can extend the piercing capability of the system in some cases. Because this can be a complex process that can damage the torch or other components, a stationary or edge start is recommended.

Common machine-cutting faults

The torch's pilot arc will initiate, but will not transfer.

- The work lead is not making good contact with the cutting table, or the cutting table is not making good contact with the workpiece.
- The torch-to-work distance/cut height is too large.

The workpiece is not totally pierced, and there is excessive sparking on the top of the workpiece.

- The metal surface is not clean of rust or paint.
- The consumables are worn and need to be replaced. For optimized performance in a mechanized application, replace the nozzle and the electrode together.
- The work lead is not making good contact with the cutting table, or the cutting table is not making good contact with the workpiece.
- The current (amperage) is set too low. See the system's Operator Manual for more information.
- The cut speed is too high. See the cut charts in the system's Operator Manual for more information.
- The metal being cut exceeds the maximum capacity for the selected amperage. See the system's Operator Manual for more information.

Excessive dross forms on the bottom of the cut.

- The gas setting is too high or too low.
- The consumables are worn and need to be replaced. For optimized performance in a mechanized application, replace the nozzle and the electrode together.
- The cutting speed is not correct. See the cut charts in the system's Operator Manual for more information.
- The current (amperage) is set too low. See the cut charts in the system's Operator Manual for more information.

The cut angle is not square.

- The torch is not square to the workpiece.
- The gas setting is incorrect.
- The consumables are worn and need to be replaced. For optimized performance in a mechanized application, replace the nozzle and the electrode together.
- The direction of the torch travel is incorrect. The high-quality cut is always on the right with respect to the forward motion of the torch.
- The torch-to-work distance/cut height is too large or too small.
- The cutting speed is not correct. See the cut charts in the system's Operator Manual for more information.

The consumable life is shortened.

- The gas setting is incorrect.
- The arc current, arc voltage, travel speed, and other variables are not set as recommended in the cut charts.
- The torch is fired into the air (beginning or ending the cut off of the plate surface). Starting at the edge is acceptable as long as the arc makes contact with the workpiece when started.
- A pierce is started with an incorrect torch height. See the cut charts in the system's Operator Manual for the specific initial pierce height.
- The pierce time is incorrect.

3 – Operation

- The air quality is poor (oil or water in the air).
- There might be a faulty pilot arc IGBT, which can shorten nozzle life.
- The swirl ring or retaining cap is worn and needs to be replaced.

Section 4

Component Replacement

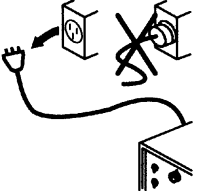
	<p>WARNING! ELECTRIC SHOCK CAN KILL</p>
	<p>Disconnect electrical power before performing any maintenance.</p> <p>The maintenance procedures in this section must be performed by a qualified technician.</p> <p>See the <i>Safety and Compliance Manual (80669C)</i> for more safety precautions.</p>

Duramax and Duramax Hyamp robotic torch overview

The instructions to replace components in all 6 models of robotic torches (180°, 90°, and 45°) are very similar. Any differences are noted in the steps. The 45° Duramax and Duramax Hyamp robotic torches are shown in the figures that follow.

-  While disconnecting and reconnecting the torch parts, maintain the same orientation between the torch body and torch lead. Twisting the torch body in relation to the torch lead can cause damage.

Figure 21 – Duramax 45°



- | | | | |
|---|--------------------------------------|----|-------------------------------------|
| 1 | Right half of the positioning barrel | 7 | Gas fitting flange |
| 2 | Cap-sensor switch connector | 8 | Positioning barrel screws (6) |
| 3 | Cap-sensor switch | 9 | Left half of the positioning barrel |
| 4 | Pilot terminal screw | 10 | Torch lead |
| 5 | Torch body (torch head and gas tube) | 11 | Strain relief |
| 6 | Gas supply tube fitting | | |

Figure 22 – Duramax Hyamp 45°

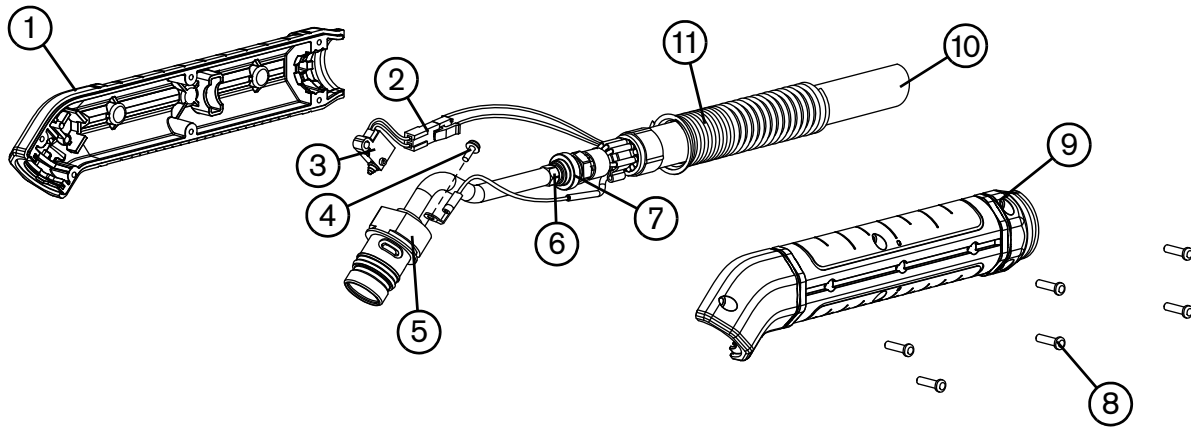
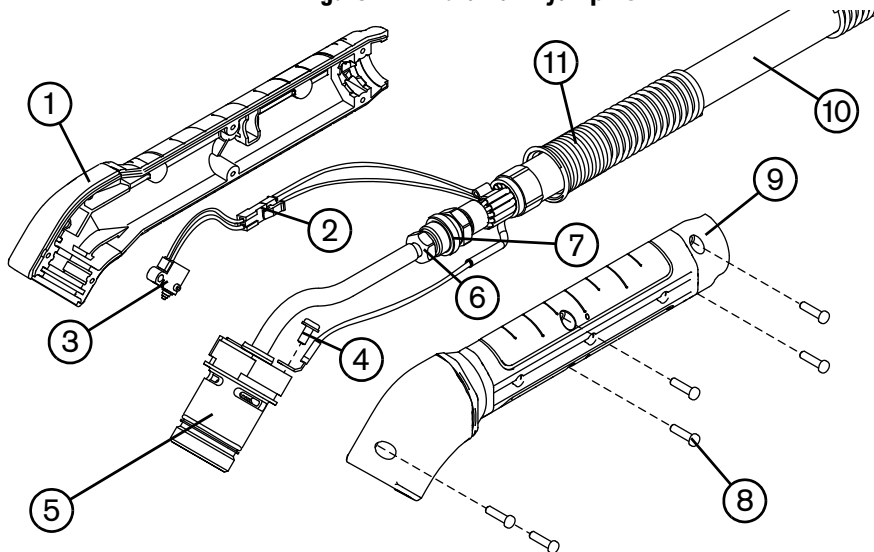

- | | | | |
|---|--------------------------------------|----|-------------------------------------|
| 1 | Right half of the positioning barrel | 7 | Gas fitting flange |
| 2 | Cap-sensor switch connector | 8 | Positioning barrel screws (6) |
| 3 | Cap-sensor switch | 9 | Left half of the positioning barrel |
| 4 | Pilot terminal screw | 10 | Torch lead |
| 5 | Torch body (torch head and gas tube) | 11 | Strain relief |
| 6 | Gas supply tube fitting | | |

Disconnect the power, gas supply, and torch

1. Turn the plasma power supply switch to OFF (O).
2. Turn the line disconnect switch to OFF (O).
3. Disconnect the gas supply hose from the plasma power supply.
4. Disconnect the torch from the plasma power supply.

Figure 23

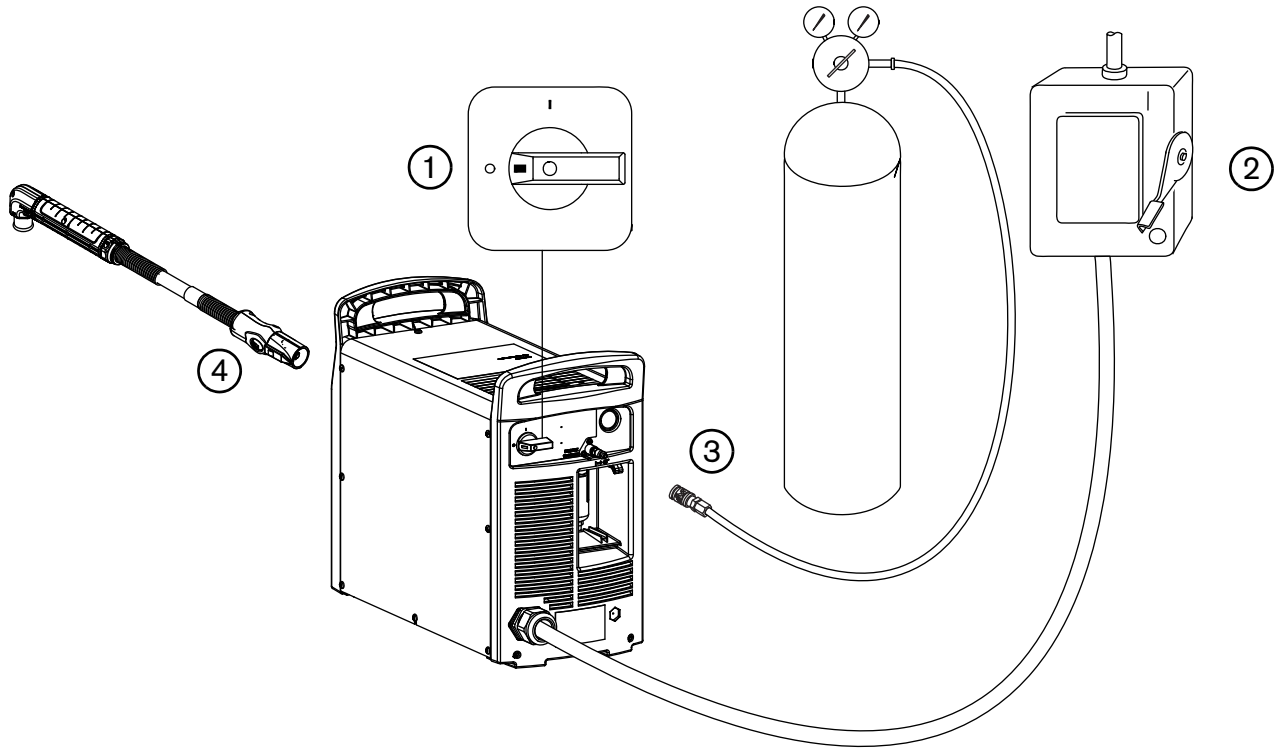



Replacing the positioning barrel

Kit	Description
228856	<i>Kit: Duramax 180° robotic torch positioning barrel replacement</i>
228857	<i>Kit: Duramax 90° robotic torch positioning barrel replacement</i>
228858	<i>Kit: Duramax 45° robotic torch positioning barrel replacement</i>
428295	<i>Kit: Duramax Hyamp 180° robotic torch barrel replacement</i>
428294	<i>Kit: Duramax Hyamp 90° robotic torch barrel replacement</i>
428293	<i>Kit: Duramax Hyamp 45° robotic torch barrel replacement</i>

Remove the positioning barrel

1. Turn OFF (O) the power, disconnect the gas supply, and disconnect the torch.
2. Remove the consumables from the torch.
3. Place the torch on a flat surface with the left half of the positioning barrel facing up.

 The left half of the positioning barrel is the side with the screws.

 It may be helpful to clamp the lead in place to keep it from moving.

4. Remove the screws from the left half of the positioning barrel.
5. Lift the left half of the positioning barrel away from the torch.
6. The torch body fits snugly into the right half of the positioning barrel. While holding the torch body, gently press the right half of the positioning barrel away from the torch body to remove it.
7. Slide the cap-sensor switch off its mounting post.

Figure 24 – Duramax 45° (top) and Duramax Hyamp 45° (bottom)

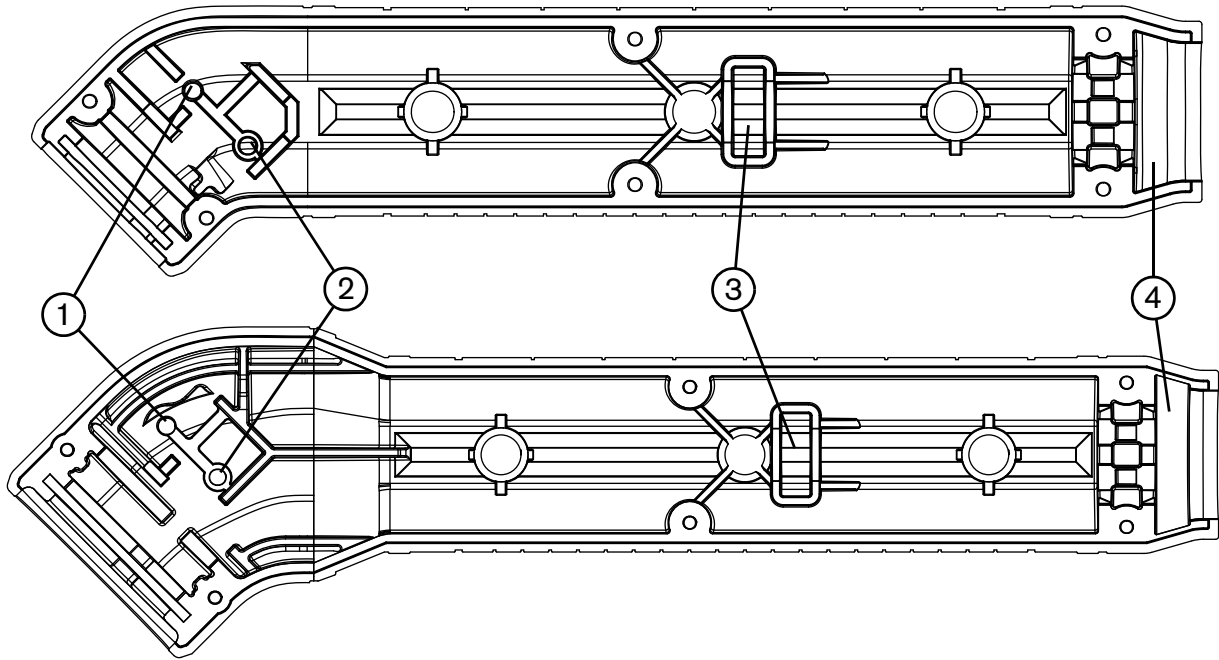

- | | |
|-----------------------------------|---------------------------|
| 1 Cap-sensor switch mounting post | 3 Gas fitting flange slot |
| 2 Cap-sensor switch post hole | 4 Strain relief slot |

Install the positioning barrel

1. Lay the right half of the positioning barrel on a flat surface with the inside facing up.



If replacing the positioning barrel, use the new barrel halves included in the kit.

2. Press the cap-sensor switch into its post hole and onto its mounting post. (See *Figure 24*.)
3. Route the cap-sensor wires below the slot for the gas hose fitting's flange.
4. Route the pilot arc wire under the gas tube and above the slot for the gas hose fitting's flange. (See *Figure 25* and *Figure 26*.)

Figure 25 – Duramax wire routing

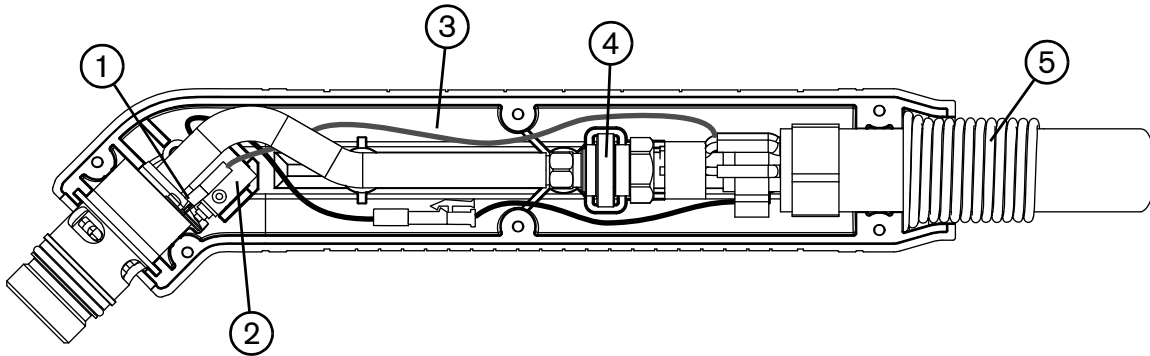

- | | |
|-------------------------------|----------------------|
| 1 Pilot arc wire terminal | 4 Gas fitting flange |
| 2 Cap-sensor switch | 5 Strain relief slot |
| 3 Cap-sensor switch connector | |

Figure 26 – Duramax Hyamp wire routing

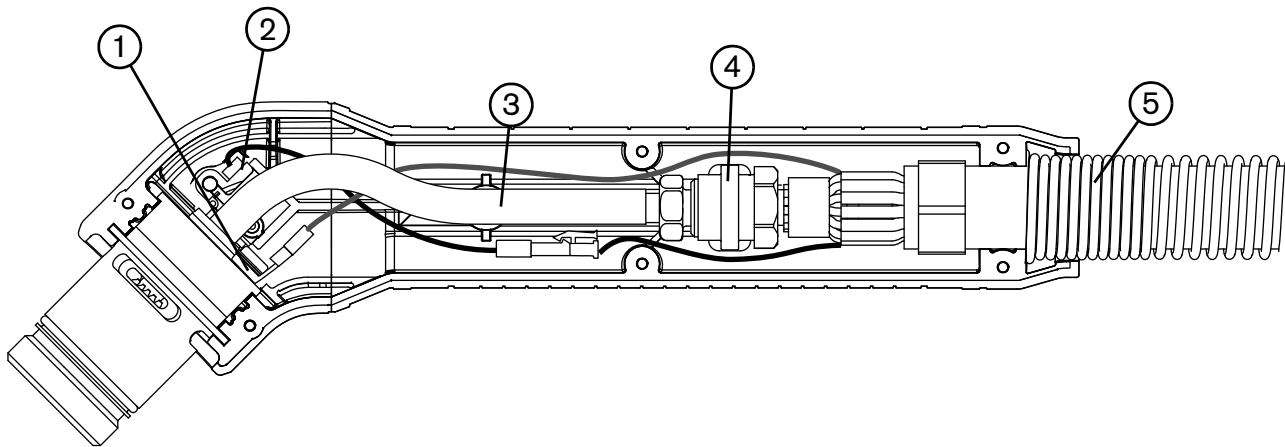

- | | |
|-------------------------------|----------------------|
| 1 Pilot arc wire terminal | 4 Gas fitting flange |
| 2 Cap-sensor switch | 5 Strain relief slot |
| 3 Cap-sensor switch connector | |

5. Press the torch body into the right half of the positioning barrel with the gas fitting flange aligned with the slot in the positioning barrel.
6. Align the strain relief with the strain relief slot in the positioning barrel.
7. Being careful that the positioning barrel and gas fitting flange do not pinch the wires, align the left half of the positioning barrel with the right half.
8. Install the screws in the left half of the positioning barrel. Tighten to 15.0 kg·cm (13.0 inch-pounds).

9. If the O-ring on the torch body is dry, lubricate it and the threads with a thin layer of silicone lubricant.



Silicone lubricant is included in several of the replacement kits.

10. Install the consumables.

11. Reconnect the torch and gas supply, and turn ON (I) the power.

Replacing the torch body

Kit	Description
228853	Kit: Duramax 180° robotic torch main body replacement
228854	Kit: Duramax 90° robotic torch main body replacement
228855	Kit: Duramax 45° robotic torch main body replacement
428298	Kit: Duramax Hyamp 180° robotic torch main body replacement
428297	Kit: Duramax Hyamp 90° robotic torch main body replacement
428296	Kit: Duramax Hyamp 45° robotic torch main body replacement

1. Complete the following procedures:
 - a. See *Disconnect the power, gas supply, and torch* on page 55.
 - b. Remove all components from the torch. See *Remove the positioning barrel* on page 56.
2. Remove the pilot terminal screw.
3. Use 2 wrenches to loosen the gas fitting that secures the torch body to the torch lead.



Heating the gas fitting can help loosen the threadlocker and make removing the torch body easier. Slowly heat only the fitting with a heat gun until you can easily loosen the fitting.



CAUTION!

Do not apply heat to the wires. Heating the wires could cause damage to the connections in the torch lead.



CAUTION!

Always use 2 wrenches to properly loosen and tighten the hex nuts and bolts mentioned in these procedures. A strong threadlocker is used to assemble the torch, and loosening the nuts incorrectly can damage the threads.

4 – Component Replacement

- Being careful not to get any threadlocker on the conical surface of the gas tube fitting, apply a drop of threadlocker, included in the kit, to the threads of the gas tube fitting on the torch body.

 The drop should not be wider than 2 threads in diameter.



CAUTION!

Do not get any threadlocker on the conical surface of the gas tube fitting to avoid causing damage to the torch. If any threadlocker does get on this surface, clean it off immediately.

Figure 27

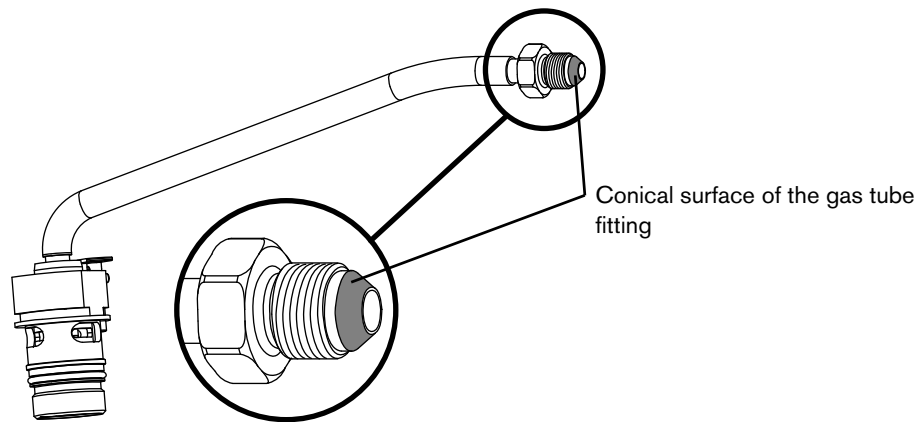

- Thread the torch body into the torch lead until snug.

 The white wires of the lead should be facing up.

- Use 2 wrenches to tighten the gas fitting that secures the torch body to the torch lead to 69.1 kg-cm (60 inch-pounds).
- Route the pilot arc wire under the gas tube and above the slot for the gas hose fitting's flange. (See *Figure 25* and *Figure 26*.)
- Tighten the pilot terminal screw to 17.3 kg-cm (15 inch-pounds).

 The wire should go slightly down into the positioning barrel.
- Complete the following procedures:
 - Install all of the torch components that you removed. See *Install the positioning barrel* on page 57.
 - Reconnect the torch and gas supply, and turn ON (I) the power.

Replacing the cap-sensor switch

Kit	Description
228109	Kit: Cap-sensor switch replacement

1. Complete the following procedures:
 - a. See *Disconnect the power, gas supply, and torch* on page 55.
 - b. Remove all components from the torch. See *Remove the positioning barrel* on page 56.
2. Disconnect the cap-sensor switch by pressing the tab on the connector and pulling the connector apart.

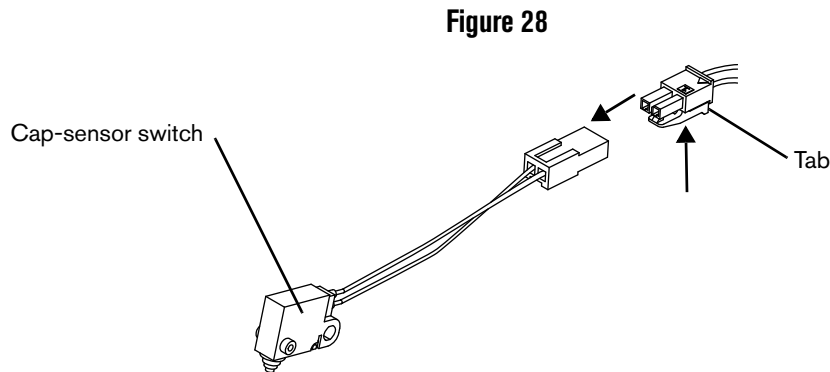

3. Connect the new cap-sensor switch to the torch lead by pushing the mating plug on the torch lead wires into the socket.
4. Complete the following procedures:
 - a. Install all of the torch components that you removed. See *Install the positioning barrel* on page 57.
 - b. Reconnect the torch and gas supply, and turn ON (I) the power.

Replacing the torch lead

Kit	Description
228852	Kit: Robotic torch lead replacement, 7.6 m (25 feet)
428813	Kit: Robotic torch lead replacement, 15 m (50 feet)
428292	Kit: Duramax Hyamp robotic torch lead replacement, 7.6 m (25 feet)
428814	Kit: Duramax Hyamp robotic torch lead replacement, 15 m (50 feet)

1. Complete the following procedures:
 - a. See *Disconnect the power, gas supply, and torch* on page 55.
 - b. Remove all components from the torch. See *Remove the positioning barrel* on page 56.
2. Disconnect the cap-sensor switch.

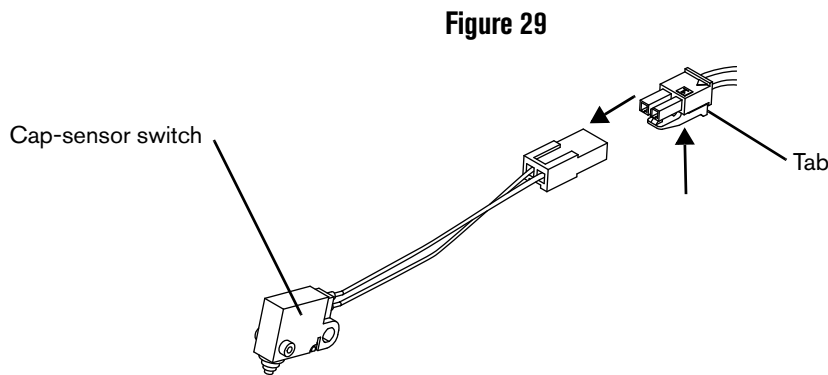

3. Remove the pilot terminal screw.
4. Use 2 wrenches to loosen the gas fitting that secures the torch body to the torch lead.

 Heating the gas fitting can help loosen the threadlocker and make removing the torch body easier. Slowly heat only the fitting with a heat gun until you can easily loosen the fitting.



CAUTION!

Do not apply heat to the wires. Heating the wires could cause damage to the connections in the torch lead.

**CAUTION!**

Always use 2 wrenches to properly loosen and tighten the hex nuts and bolts mentioned in these procedures. A strong threadlocker is used to assemble the torch, and loosening the nuts incorrectly can damage the threads.

- Being careful not to get any threadlocker on the conical surface of the gas tube fitting, apply a drop of threadlocker, included in the kit, to the threads of the gas tube fitting on the torch body.

 The drop should not be wider than 2 threads in diameter.

**CAUTION!**

Do not get any threadlocker on the conical surface of the gas tube fitting to avoid causing damage to the torch. If any threadlocker does get on this surface, clean it off immediately.

Figure 30

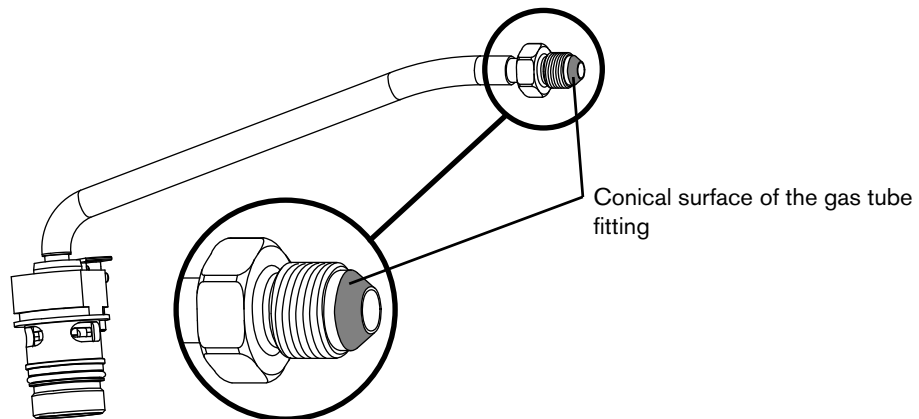

- Thread the torch body into the torch lead until snug.

 The white wires of the lead should be facing up.

- Use 2 wrenches to tighten the gas fitting that secures the torch body to the torch lead to 69.1 kg·cm (60 inch-pounds).

- Route the pilot arc wire under the gas tube. (See *Figure 25* and *Figure 26*.)

- Tighten the pilot terminal screw to 17.3 kg·cm (15 inch-pounds).

 The wire should go slightly down into the positioning barrel.

4 – Component Replacement

10. Connect the cap-sensor switch.

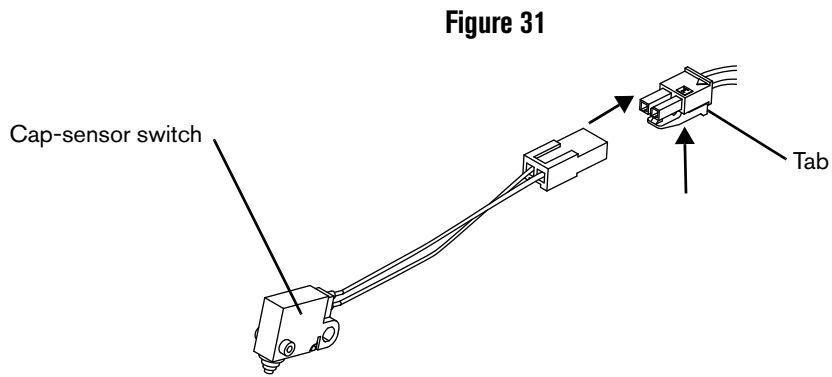



11. Complete the following procedures:

- a. Install all of the components that you removed. See *Install the positioning barrel* on page 57.
- b. Reconnect the torch and gas supply, and turn ON (I) the power.

Section 5
Maintenance and Parts

Perform routine maintenance

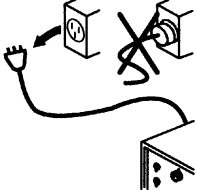
		WARNING! ELECTRIC SHOCK CAN KILL
		<p>Disconnect electrical power before performing any maintenance. See the <i>Safety and Compliance Manual (80669C)</i> for more safety precautions.</p>

Routine maintenance tasks

Every use:

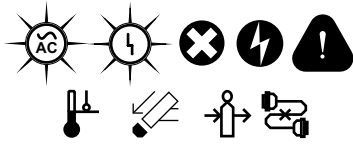

Check indicator lights and fault icons.
Correct any fault conditions.

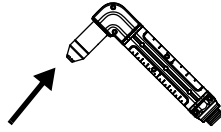

Inspect the consumables for proper installation and wear.

Every 3 months:



Replace any damaged labels.

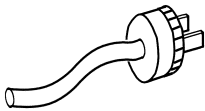

Inspect the power cord and plug. Replace if damaged.

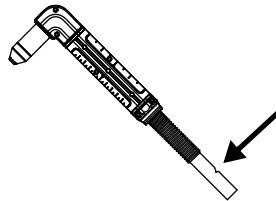

Inspect the torch lead. Replace if damaged.

Every 6 months:

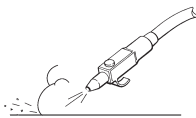

or

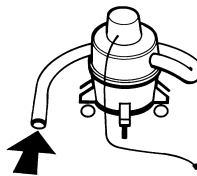

Clean the inside of the power supply with moisture-free compressed air or a vacuum.

Inspect the consumables

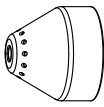
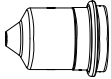
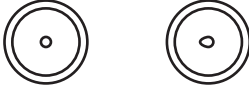
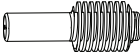
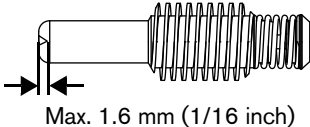
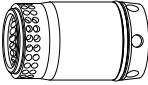
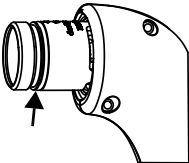
Part	Inspect	Action
 <p>Shield</p>	<p>The center hole for roundness.</p> <p>The gap between the shield and the nozzle for accumulated debris.</p>	<p>Replace the shield if the hole is no longer round.</p> <p>Remove the shield and clean away any material.</p>
 <p>Nozzle</p>	<p>The center hole for roundness.</p> 	<p>Replace the nozzle if the center hole is not round.</p> <p>Replace the nozzle and the electrode together.</p>
 <p>Electrode</p>	 <p>Max. 1.6 mm (1/16 inch)</p>	<p>Replace the electrode if the surface is worn or the pit depth is greater than 1.6 mm (1/16 inch) deep.</p> <p>Replace the nozzle and electrode together.</p>
 <p>Swirl ring</p>	<p>The surface inside the swirl ring for damage or wear and the gas holes for blockages.</p> <p>The O-ring for damage or wear.</p> <p>The length of the swirl ring.</p>	<p>Replace the swirl ring if the surface is damaged or worn or any of the gas holes are blocked.</p> <p>If the O-ring is worn or damaged, replace it. (See <i>Duramax robotic torch replacement parts</i> on page 68 or <i>Duramax Hyamp robotic torch replacement parts</i> on page 71.)</p> <p>Duramax Hyamp: If the length of the 220997 swirl ring is less than 32 mm (1.27 inches), replace it.</p> <p>Duramax: If the length of the 220994, 220947, or 220857 swirl ring is less than 30.5 mm (1.20 inches), replace it.</p>
 <p>Torch O-ring</p>	<p>The surface for damage, wear, or a lack of lubrication.</p>	<p>If the O-ring is dry, lubricate it and the threads with a thin layer of silicone lubricant. If the O-ring is worn or damaged, replace it. (See <i>Duramax robotic torch replacement parts</i> on page 68.)</p>

Duramax robotic torch replacement parts

Duramax 180° robotic torch

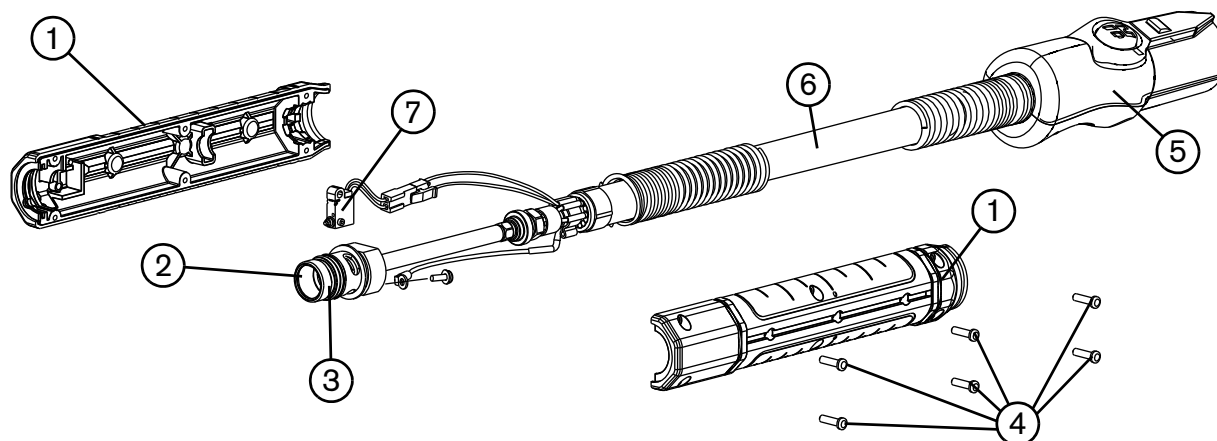

The entire Duramax 180° robotic torch assembly with leads can be replaced, or individual component parts can be replaced.

Part Number	Description
059466	Duramax 180° robotic torch assembly with leads, 7.6 m (25 feet)
059587	Duramax 180° robotic torch assembly with leads, 15 m (50 feet)
1 228856	Kit: Duramax 180° robotic torch positioning barrel replacement
2 228853	Kit: Duramax 180° robotic torch main body replacement
3 058519	O-ring
4 075714	Positioning barrel screws
5 428260	Kit: FastConnect replacement
6 228852	Kit: Robotic torch lead replacement, 7.6 m (25 feet)
6 428813	Kit: Robotic torch lead replacement, 15 m (50 feet)
7 228109	Kit: Cap-sensor switch replacement

Duramax 90° robotic torch

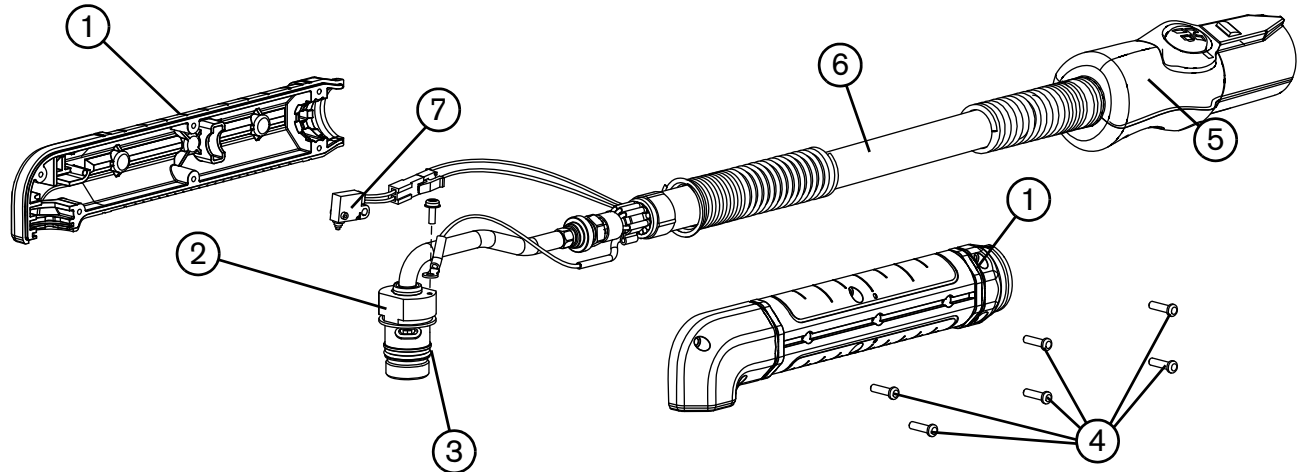

The entire Duramax 90° robotic torch assembly with leads can be replaced, or individual component parts can be replaced.

Part Number	Description
059465	Duramax 90° robotic torch assembly with leads, 7.6 m (25 feet)
059586	Duramax 90° robotic torch assembly with leads, 15 m (50 feet)
1 228857	Kit: Duramax 90° robotic torch positioning barrel replacement
2 228854	Kit: Duramax 90° robotic torch main body replacement
3 058519	O-ring
4 075714	Positioning barrel screws
5 428260	Kit: FastConnect replacement
6 228852	Kit: Robotic torch lead replacement, 7.6 m (25 feet)
6 428813	Kit: Robotic torch lead replacement, 15 m (50 feet)
7 228109	Kit: Cap-sensor switch replacement

Duramax 45° robotic torch

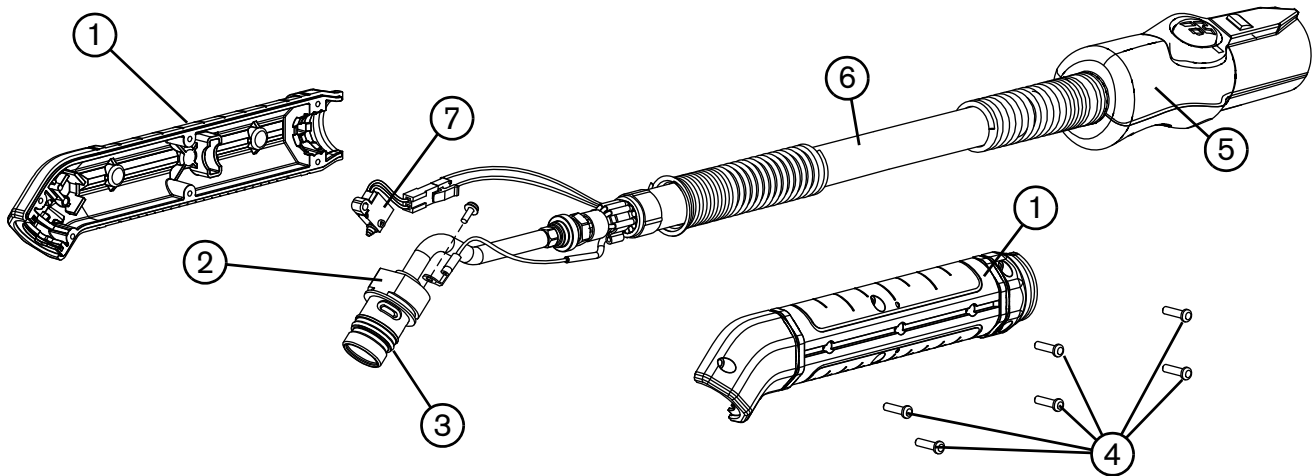

The entire Duramax 45° robotic torch assembly with leads can be replaced, or individual component parts can be replaced.

Part Number	Description
059464	Duramax 45° robotic torch assembly with leads, 7.6 m (25 feet)
059585	Duramax 45° robotic torch assembly with leads, 15 m (50 feet)
1 228858	Kit: Duramax 45° robotic torch positioning barrel replacement
2 228855	Kit: Duramax 45° robotic torch main body replacement
3 058519	O-ring
4 075714	Positioning barrel screws
5 428260	Kit: FastConnect replacement
6 228852	Kit: Robotic torch lead replacement, 7.6 m (25 feet)
6 428813	Kit: Robotic torch lead replacement, 15 m (50 feet)
7 228109	Kit: Cap-sensor switch replacement

Duramax Hyamp robotic torch replacement parts

Duramax Hyamp 180° robotic torch

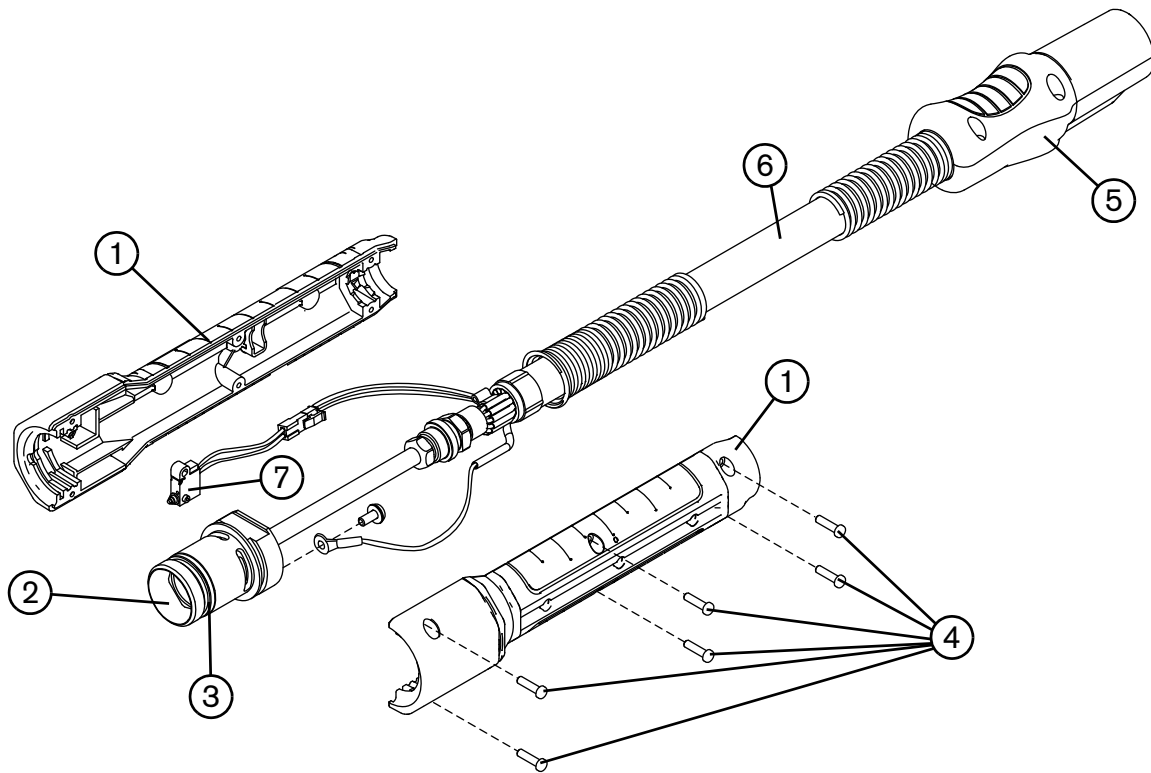

The entire Duramax Hyamp 180° robotic torch assembly with leads can be replaced, or individual component parts can be replaced.

Part Number	Description
059566	Duramax Hyamp 180° robotic torch assembly with leads, 7.6 m (25 feet)
059672	Duramax Hyamp 180° robotic torch assembly with leads, 15 m (50 feet)
1 428295	Kit: Duramax Hyamp 180° robotic torch barrel replacement
2 428298	Kit: Duramax Hyamp 180° robotic torch main body replacement
3 428253	O-ring (5)
4 075714	Positioning barrel screws
5 428260	Kit: FastConnect replacement
6 428292	Kit: Duramax Hyamp robotic torch lead replacement, 7.6 m (25 feet)
6 428814	Kit: Duramax Hyamp robotic torch lead replacement, 15 m (50 feet)
7 228109	Kit: Cap-sensor switch replacement

Duramax Hyamp 90° robotic torch

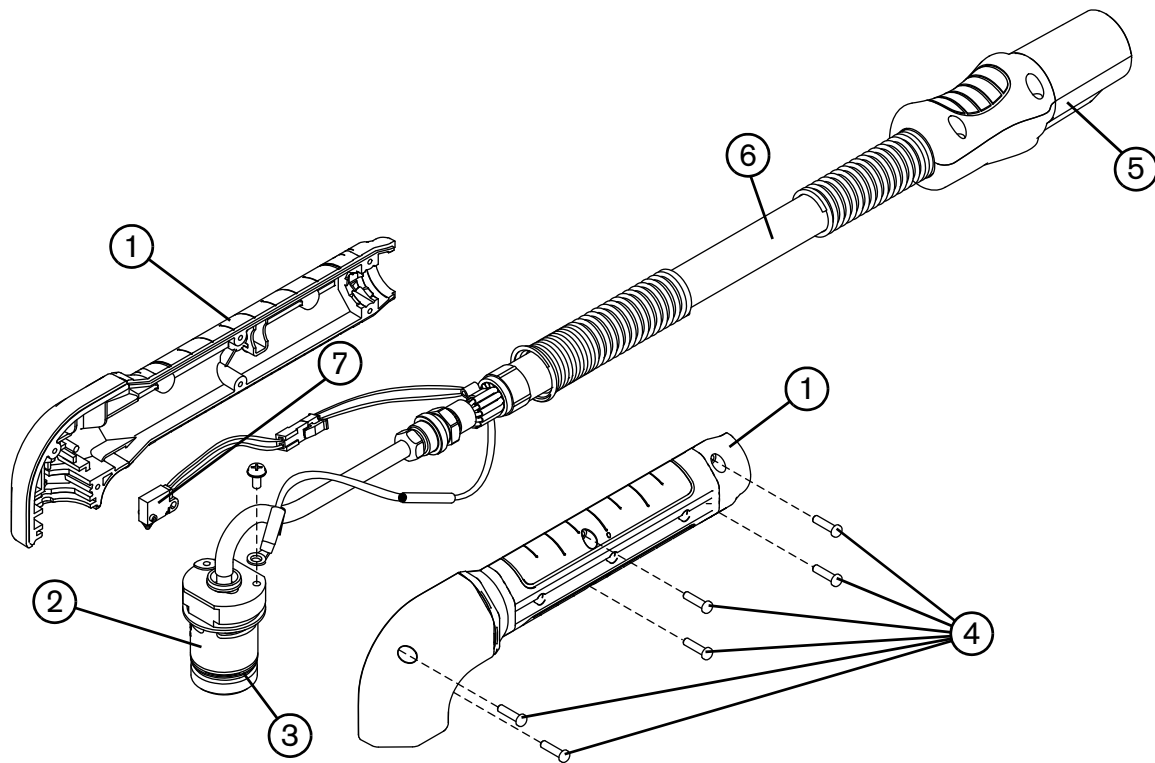

The entire Duramax Hyamp 90° robotic torch assembly with leads can be replaced, or individual component parts can be replaced.

Part Number	Description
059565	Duramax Hyamp 90° robotic torch assembly with leads, 7.6 m (25 feet)
059671	Duramax Hyamp 90° robotic torch assembly with leads, 15 m (50 feet)
1 428294	Kit: Duramax Hyamp 90° robotic torch barrel replacement
2 428297	Kit: Duramax Hyamp 90° robotic torch main body replacement
3 428253	O-ring (5)
4 075714	Positioning barrel screws
5 428260	Kit: FastConnect replacement
6 428292	Kit: Duramax Hyamp robotic torch lead replacement, 7.6 m (25 feet)
6 428814	Kit: Duramax Hyamp robotic torch lead replacement, 15 m (50 feet)
7 228109	Kit: Cap-sensor switch replacement

Duramax Hyamp 45° robotic torch

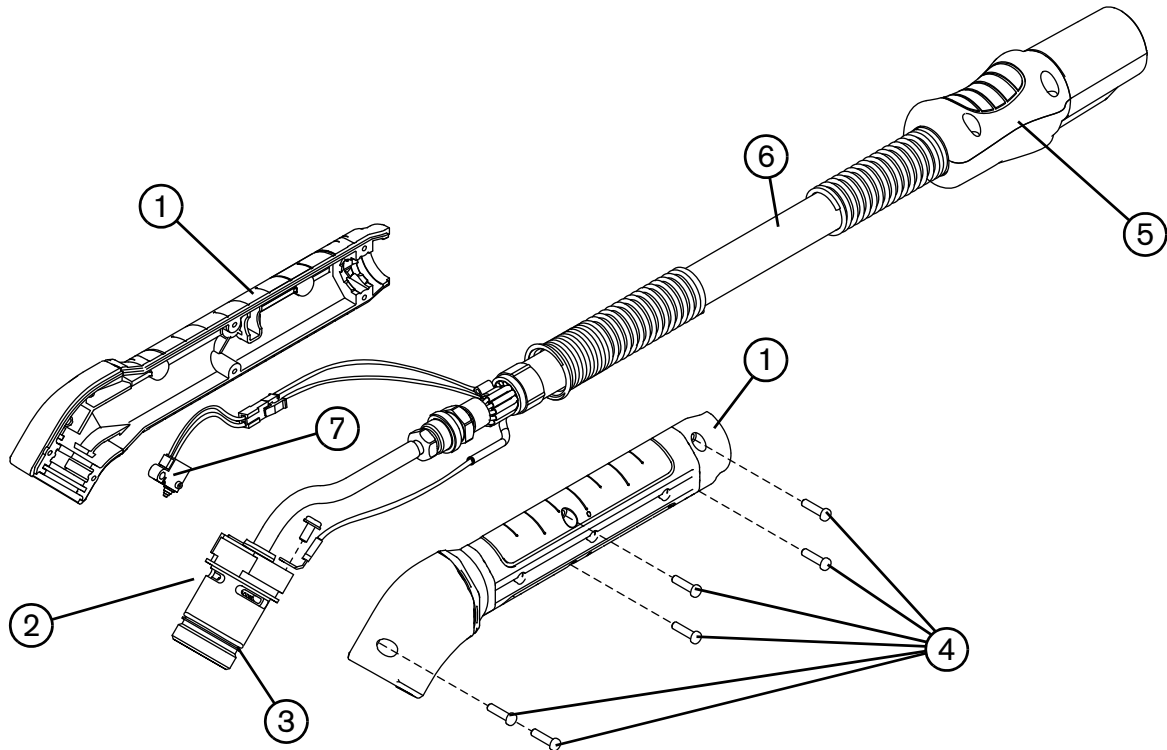

The entire Duramax Hyamp 45° robotic torch assembly with leads can be replaced, or individual component parts can be replaced.

Part Number	Description
059564	Duramax Hyamp 45° robotic torch assembly with leads, 7.6 m (25 feet)
059670	Duramax Hyamp 45° robotic torch assembly with leads, 15 m (50 feet)
1 428293	Kit: Duramax Hyamp 45° robotic torch barrel replacement
2 428296	Kit: Duramax Hyamp 45° robotic torch main body replacement
3 428253	O-ring (5)
4 075714	Positioning barrel screws
5 428260	Kit: FastConnect replacement
6 428292	Kit: Duramax Hyamp robotic torch lead replacement, 7.6 m (25 feet)
6 428814	Kit: Duramax Hyamp robotic torch lead replacement, 15 m (50 feet)
7 228109	Kit: Cap-sensor switch replacement

Accessory parts

Part Number	Description
024877	Black leather torch sheathing with Hypertherm logo, 7.6 m (25 feet)
228806	Kit: Robotic clamp torch assembly
229456	Duramax robotic torch teach assembly
229832	Duramax Hyamp robotic torch teach assembly